



**MINUTES
ORDINARY COUNCIL MEETING**

19 DECEMBER 2018

The Chief Executive Officer recommends the endorsement of these minutes at the next Ordinary Meeting of Council.

Signed: 
(CEO)

Date **20 December 2018**

These minutes were confirmed at the Ordinary Council Meeting held on

Signed:
(Presiding Person at the meeting at which minutes were confirmed)

DISCLAIMER

Council and Committee agendas, recommendations, minutes and resolutions are subject to confirmation by the Council or Committee and therefore, prior to relying on them, one should refer to the subsequent meeting of Council or the Committee with respect to their accuracy.

No responsibility whatsoever is implied or accepted by the Shire of Narrogin for any act, omission or statement or intimation occurring during Council/Committee meetings or during formal/informal conversations with staff.

The Shire of Narrogin disclaims any liability for any loss whatsoever and howsoever caused arising out of reliance by any person or legal entity on any such act, omission or statement or intimation occurring during Council/Committee meetings or discussions. Any person or legal entity who acts or fails to act in reliance upon any statement does so at that person's or legal entity's own risk.

In particular and without derogating in any way from the broad disclaimer above, in any discussion regarding any planning application or application for a license, any statement or limitation or approval made by a member or officer of the Shire of Narrogin during the course of any meeting is not intended to be and is not taken as notice of approval from the Shire of Narrogin. The Shire of Narrogin warns that anyone who has an application lodged with the Shire of Narrogin must obtain and should only rely on WRITTEN CONFIRMATION of the outcome of the application, and any conditions attaching to the decision made by the Shire of Narrogin in respect of the application.

Please note that meetings may be recorded for minute taking purposes.

CONTENTS

Agenda Item	Page
1. OFFICIAL OPENING/ANNOUNCEMENT OF VISITORS	5
2. RECORD OF ATTENDANCE/APOLOGIES/APPROVED LEAVE OF ABSENCE	5
3. DECLARATION OF INTEREST BY ELECTED MEMBERS AND COUNCIL EMPLOYEES IN MATTERS INCLUDED IN THE MEETING AGENDA	5
4. RESPONSE TO PREVIOUS PUBLIC QUESTIONS TAKEN ON NOTICE	6
5. PUBLIC QUESTION TIME	6
6. APPLICATIONS FOR LEAVE OF ABSENCE	6
7. CONFIRMATION OF MINUTES OF PREVIOUS MEETINGS	6
8. ANNOUNCEMENTS BY THE PERSON PRESIDING WITHOUT DISCUSSION	6
9. PETITIONS, DEPUTATIONS, PRESENTATIONS OR SUBMISSIONS	7
10. MATTERS WHICH REQUIRE DECISIONS	8
10.1 DEVELOPMENT AND REGULATORY SERVICES	8
10.1.1 APPLICATION FOR PLANNING CONSENT – OUTBUILDING (ANCILLARY) AT LOT 1561 CLAYTON ROAD, NARROGIN	8
10.1.2 LANDFILL TIP PASSES – LOT 1633 (RESERVE 8410) WHITE ROAD, NARROGIN	27
10.1.3 APPLICATION FOR ANNUAL RENEWAL – TEMPORARY MOBILE CONCRETE BATCHING PLANT AT LOT 5 EARL STREET, NARROGIN	31
10.1.4 AUSTRALIA DAY AND HONOURS COMMITTEE TERMS OF REFERENCE - AMENDED	39
10.2 TECHNICAL AND RURAL SERVICES	51
10.2.1 AWARDING OF REQUEST FOR QUOTATION 18/1 –10 ROAD PROFILING AND ASPHALT	51
10.3 CORPORATE AND COMMUNITY SERVICES	55
10.3.1 SCHEDULE OF ACCOUNTS PAID – NOVEMBER 2018	55
10.3.2 MONTHLY FINANCIAL REPORTS – NOVEMBER 2018	57
10.3.3 PROPOSED SALE OF LAND LOT 1224 (NUMBER 45) FORREST STREET NARROGIN ASSESSMENT A186100- DUE TO UNPAID RATES	75
10.3.4 DRAFT COMPLAINTS MANAGEMENT POLICY	80
10.4 OFFICE OF THE CHIEF EXECUTIVE OFFICER	88
10.4.1 CONDUCT OF 2019 LOCAL GOVERNMENT ELECTION	88
10.4.2 CHIEF EXECUTIVE OFFICER PERFORMANCE APPRAISAL	93

11. ELECTED MEMBERS' MOTIONS OF WHICH PREVIOUS NOTICE HAS BEEN GIVEN	96
12. NEW BUSINESS OF AN URGENT NATURE APPROVED BY THE PERSON PRESIDING OR BY DECISION OF THE MEETING	96
13. CLOSURE OF MEETING	96

ORDINARY COUNCIL MEETING AGENDA

19 DECEMBER 2018

1. OFFICIAL OPENING/ANNOUNCEMENT OF VISITORS

The Presiding Member, President Ballard, declared the meeting open at 7:02 pm.

2. RECORD OF ATTENDANCE/APOLOGIES/APPROVED LEAVE OF ABSENCE

Elected Members (Voting)

Mr L Ballard – Shire President (Presiding Member)
Cr T Wiese – Deputy Shire President
Cr C Ward
Cr N Walker
Cr M Fisher
Cr C Bartron
Cr B Seale
Cr G Ballard

Staff

Mr D Stewart – Chief Executive Officer
Mr A Awang – Executive Manager Development & Regulatory Services
Mr T Evans – Executive Manager Technical & Rural Services
Mr F Ludovico – Executive Manager Corporate & Community Services
Ms C Thompson – Executive Assistant

Leave of Absence

Cr P Schutz

3. DECLARATION OF INTEREST BY ELECTED MEMBERS AND COUNCIL EMPLOYEES IN MATTERS INCLUDED IN THE MEETING AGENDA

Name	Item No	Interest	Nature
Dale Stewart	10.4.1	Financial & Impartiality	The officer is the default returning officer in the event that the Council does not make a declaration.
Dale Stewart	10.4.2	Financial & Impartiality	The item relates to the employment contract and conditions of employment of the author
Cr Fisher	10.1.3	Financial	The applicant is a client of Cr Fisher's business.

4. RESPONSE TO PREVIOUS PUBLIC QUESTIONS TAKEN ON NOTICE

Nil

5. PUBLIC QUESTION TIME

Nil

6. APPLICATIONS FOR LEAVE OF ABSENCE

The next meeting is scheduled for 27 February 2019.

Cr Fisher advised Council that he will be away for the Ordinary Council Meeting of 27 February 2019.

COUNCIL RESOLUTION 1218.123

Moved: Cr Ward Seconded: Cr Seale

That Council approve Cr Fisher's request for leave of absence for the Ordinary Council Meeting of 27 February 2019.

CARRIED 8/0

7. CONFIRMATION OF MINUTES OF PREVIOUS MEETINGS

7.1 Ordinary Council Meeting

OFFICERS' RECOMMENDATION AND COUNCIL RESOLUTION 1218.124

Moved: Cr Seale Seconded: Cr Bartron

That the minutes of the Ordinary Council Meeting held 28 November 2018 be confirmed as an accurate record of the proceedings.

CARRIED 8/0

8. ANNOUNCEMENTS BY THE PERSON PRESIDING WITHOUT DISCUSSION

The 2018 Narrogin and Highbury Christmas Lights competition was judged during the period 14-18 December during the hours of 7 and 9 pm.

The winners of Narrogin Chamber of Commerce vouchers were announced as follows:

1st Prize – (Value \$250) – won by 45 Fox Street Narrogin (Mr & Mrs Alan Donaldson)

2nd Prize – (Value \$200) – won by 82 Clayton Road (Mrs Chloe Campbell)

3rd Prize – (Value \$150) – won by 5 Ashworth Crescent (Mr Robert Lee)

The judges also thought two other addresses were worthy of commendation namely, the light displays at 71 Clayton Road (Ms Mandy Kulker), and 100 Bannister Street (Ms Susan Schmerer).

The Administration will contact the winners and send a media release advising who the winners were for 2018.

9. PETITIONS, DEPUTATIONS, PRESENTATIONS OR SUBMISSIONS

Nil

10. MATTERS WHICH REQUIRE DECISIONS

10.1 DEVELOPMENT AND REGULATORY SERVICES

10.1.1 APPLICATION FOR PLANNING CONSENT – OUTBUILDING (ANCILLARY) AT LOT 1561 CLAYTON ROAD, NARROGIN

File Reference	A105213
Disclosure of Interest	Neither the Author nor Authorising Officer have any Impartiality, Financial or Proximity Interest that requires disclosure.
Applicant	Narrogin Racing
Previous Item Numbers	Nil
Date	7 December 2018
Author	Eric Anderson – Planning Officer
Authorising Officer	Azhar Awang – Executive Manager Development and Regulatory Services
Attachments <ol style="list-style-type: none">1. Application for planning consent2. Cover letter3. Plans and specifications4. Email confirmation of change of materials5. Lease area	

Summary

Council is requested to consider the application for planning consent for the proposed outbuilding (ancillary) for the storage of Narrogin Race and Pace Incorporated, (trading as Narrogin Racing) equipment, located at Lot 1561 Clayton Road, Narrogin.

Background

On 7 December 2018, the Shire of Narrogin received an application for planning consent for a proposed outbuilding (storage shed) at Lot 1561 Clayton Road, Narrogin. The proposed outbuilding measures 20 metres long by 9.2 metres wide, (with the doors sliding perpendicular to the shed and extending a further 4.263 metres on each side when fully open), and a height 5.81 metres. The original plans and specifications, dated 28 November 2018, show the shed to be of Zinalume and Trimdeck construction which can be highly reflective and is discouraged in residential areas or areas in which reflective objects could cause a nuisance. Given its proximity to the race track, it was recommended that Colourbond be used to reduce possible glare getting in the eyes of race horses. The applicant has advised that the application will be changed to Colourbond in an email dated 7 December 2018 (Attachment 4).

The proposed shed has been designed to store the race day barriers (starting gates). Currently the starting gates are being stored out in the open and the weather is affecting the foam buffers, rubber suction cups and tapping. The applicant has also advised in a letter (Attachment 2) that a storm last year lifted the starting gates and toppled them, rolling several times.

The initial location of the proposed outbuilding was to be where the current mature eucalyptus (gum) tree is on the eastern side of the racing track. After a site inspection was conducted with the Manager of Narrogin Racing and the Executive Manager Technical and Rural Services, the Planning Officer and the Building Surveyor, it was agreed that the outbuilding location be amended to preserve the mature eucalyptus tree. The applicant has complied and amended the proposed location further north closer to the entrance to the race track so that the barriers can be towed straight onto the track.

Comment

Zoning

The subject land is zoned "Recreation" under the former Town of Narrogin Town Planning Scheme No. 2. The land to the north and west is zoned "single residential" with the land to the east being a mix between the "other commercial" and "light industrial" zones. The current use of the land is Horse Racing Facility fits the use description of Recreation. As the outbuilding is ancillary to the predominant use (Recreation) the proposed outbuilding would be a permitted use.

Tenure

The entirety of Lot 1561 is currently the subject of a Crown grant that was issued to the former Town of Narrogin in 1966 with the authority to sub lease any portion of that land. Narrogin Racing currently has a lease on a portion of Lot 1561 dated 1 July 2012 and is due to expire on 30 June 2022.

The lease area is defined in the lease agreement as:

"Narrogin Race Track, Narrogin Pacing Track and includes; control tower, old TAB building, committee/jockey rooms building, parade ring, members shelter, storage container, stables and vet's shed complex and machinery shed as indicated on attached plans"

The Shire of Narrogin has not been able to locate the Council's copy of the lease maps, however Narrogin Racing has a copy of the leased area (Attachment 5). The proposed location of the shed is currently not contained within the lease area and is the most suitable location for the proposed development.

It is recommended that Council request the Chief Executive Officer to make arrangements to have the lease area amended to include the area of the proposed storage shed and parking area for horse floats (off Earl Street) between the tower and existing shed.

Consultation

A site visit with the applicant's representative, the Manager of Narrogin Race and Pace Inc., was undertaken by the Building Surveyor, Executive Manager Technical and Rural Services and the Planning Officer.

Statutory Environment

Former Town of Narrogin Town Planning Scheme No. 2

Policy Implications

Nil

Financial Implications

An Application for Planning Consent Fee to the value of \$147 has been paid.

Strategic Implications

Shire of Narrogin Strategic Community Plan 2017-2027	
Objective	3. Environment Objective (Conserve, protect and enhance our natural and built environment)
Outcome:	3.4 A well maintained built environment
Strategy:	3.4.1 Improve and maintain built environment

The siting of the shed has no negative impact or conflict with the draft Shire of Narrogin Master Plan or concept Plan for recreational facilities at the Clayton Road Complex.

Voting Requirements

Simple Majority

OFFICERS' RECOMMENDATION AND COUNCIL RESOLUTION 1218.125 (1 OF 2)

Moved: Cr Fisher Seconded: Cr Wiese

That, with respect to the Application for Planning Consent – Outbuilding (Ancillary) at Lot 1561 Clayton Road Narrogin, Council approve the application subject to the following conditions:

1. The approval shall expire if the development permitted is not completed within two years of approval, or within any extension of that time which, upon written application (made before or within 21 days after the expiry of the approval) to the Shire is granted by it in writing.
2. The development approved shall be in accordance with the plans and specifications submitted with the application and these shall not be altered or modified without the prior written approval of Council.
3. Any use, additions to and further intensification of any part of the development or land which is not in accordance with the original application or conditions of approval shall be subject to a further development application and consent for that use.
4. All drainage run-off associated with the development shall be contained on site or connected to the Shire's storm water drainage system to the satisfaction of the Chief Executive Officer.
5. The proposed outbuilding is for the storage of horse racing equipment only and shall not be used for commercial or habitation purposes.
6. The building is to be sited so that it does not traverse or interrupt services.
7. The building materials and colours used shall match existing buildings on the lot and are to be of non-reflective and muted tones i.e. not Zinalume.

Advice Note: The proposed building is not within the current leased area of Narrogin and Pace Inc. and an amendment to the Lease is recommended prior to issuing of a building licence and commencing construction.

CARRIED 8/0

OFFICERS' RECOMMENDATION AND COUNCIL RESOLUTION 1218.125 (2 OF 2)

Moved: Cr Ward

Seconded: Cr Walker

That, with respect to the Application for Planning Consent – Outbuilding (Ancillary) at Lot 1561 Clayton Road Narrogin, Council request the Chief Executive Officer to negotiate the amendment of the lease of Narrogin Race and Pace Inc. (Trading as Narrogin Racing) to incorporate the proposed shed area and authorise the Shire President and the Chief Executive Officer to affix the Common Seal to the lease addendum.

CARRIED 8/0

PLANNING CONSENT



89 Earl Street
PO Box 1145
Narrogin WA 6312

(09) 9890 0900

www.narrogin.wa.gov.au
enquiries@narrogin.wa.gov.au

CASHIER HOURS:
8:30am – 4:30pm
MONDAY- FRIDAY

APPLICATION FOR PLANNING CONSENT

TOWN PLANNING SCHEME NO.2

DISTRICT SCHEME

Name of Applicant	NARROGIN RACE & PACE INC T/AS NARROGIN RACING
Correspondence Address	PO BOX 178 NARROGIN 6312

I hereby apply for planning consent to:

- Use the land described hereunder for the purpose of SHED TO PARK RACING EQUIPMENT INTO.
- Erect, alter or carry out development on land described hereunder in accordance with the accompanying plans (3 copies attached)

Existing use of land	HORSE FLOAT PARKING AREA
Approximate cost of proposed development	\$ 46305 - 00.
Estimated time of completion	31/12/18
No of persons to be housed / employed after completion	N/A.

TITLES OFFICE DESCRIPTION OF LAND

LOCALITY PLAN

House No	Lot No	Location No	44-46
Plan or Diag	Street Name	EARL STREET NARROGIN WA 6312	
Certificate of Title	Volume: _____	Folio: _____	

LOT DIMENSIONS

Site area	Square metres
Frontage	Metres
Depth	metres

AUTHORITY

Applicant's Signature		Date	15/11/18
-----------------------	--	------	----------

w:\19 shared\2 ccs shared\admin\form development - admins only\new customer forms\new approved forms\application for planning consent.docx

NOTE: WHERE THE APPLICANT IS NOT THE OWNER, THE OWNER'S SIGNATURE IS REQUIRED.

NOTE: ALL OWNERS OF THE PROPERTY MUST SIGN THIS APPLICATION FORM. WHERE PROPERTY IS OWNED BY A COMPANY, AT LEAST TWO DIRECTORS OF THE COMPANY MUST SIGN THE APPLICATION.

Owner's Signature 	Date 
(SHIRE OF NARROGIN)	

NOTE: THIS FORM IS TO BE SUBMITTED IN DUPLICATE, TOGETHER WITH THREE COPIES OF PLANS, COMPRISING THE INFORMATION SPECIFIED IN THE PARTICULARS REQUIRED WITH THE APPLICATION OUTLINED BELOW.

THIS IS NOT AN APPLICATION FOR A BUILDING LICENCE

PARTICULARS REQUIRED WITH APPLICATION FOR BUILDING CONSENT

Where an application involves the erection or alteration of a building or a change in levels of a site, the plans accompanying an application for planning consent shall, unless especially exempt by the Shire:

- a. Indicate the position and describe the existing buildings and improvements on the site and indicate those which are to be removed;
- b. Indicate the position and describe the buildings and improvements proposed to be constructed, their appearance, height and proposed uses in relation to existing and proposed contours;
- c. Indicate the position, type and height of all the existing trees on the site and indicate those to be retained and those to be removed;
- d. Indicate the areas to be landscaped and the location and type of shrubs, trees and other treatment proposed;
- e. Indicate site contours and details of any proposed alteration to the natural contour of the area;
- f. Indicate car parking areas, their layout and dimensions and accessways and the position of existing and/or proposed crossovers; and
- g. Indicate site dimensions and be to metric scale.

OFFICE USE ONLY

File Reference	Application No
Date Received	Date of Approval / Refusal
Date of Notice of Decision	Officer's Signature

w:\19 shared\2 ccs shared\admin\form development - admins only\new customer forms\new approved forms\application for planning consent.docx



To Whom it May Concern

Narrogin Racing wish to lodge an application to build a machinery shed to store our track equipment.

The shed has been designed to accommodate our Race day Barriers (starting gates) as this is the main piece of equipment we need storage for. The shed needs to be a drive through with openings at each end as the barriers cannot be turned around or even manoeuvred easily.

Each year the barriers need to be serviced by a qualified technician. With the barriers being stored in the open the weather takes it toll requiring the replacement of foam buffers, rubber suction cups and taping. Not only has the weather affected the maintenance but last year a freak storm went through the race track and physically lifted the barriers and toppled them, rolling several times. With this in mind it became a matter of urgency to build a shed.

We have harness track equipment that is stored in the open, this needs to be considered to lengthen the life of this equipment.

The position chosen allows for closeness to track entry, so the barriers can drive through on to the track. It allows for the horse float car park to still maintain its space without encroaching on the area required for industry participants.

Thank you for your time and consideration of our application.

Yours sincerely,

Cathi Trefort-Budby

Manager

4th December 2018

STRUCTURAL PLAN, ELEVATIONS AND DETAILS	
CLIENT NARROGIN RACE CLUB NARROGIN 6312	SITE ADDRESS LOT 1561 CLAYTON ROAD NARROGIN
SPECIFICATIONS	
TRUSS TOP CHORD BOTTOM CHORD WEBBING	75 X 50 X 2.5 RHS 75 X 50 X 2.5 RHS 40 X 40 X 2 SHS
COLUMN C1 ROOF BRACING ROOF BRACE RB1 FLY BRACING WALL BRACING WB1 ROOF WALLS PURLINS WITH 1 ROW BRIDGING GIRTS WITH 1 ROW BRIDGING FASCIA PURLIN DOOR OUTRIGGER COLUMN DOOR OUTRIGGER STRUT	100 X 100 X 2 50 x 50 x 2.5 ANGLE 50NB PIPE 50 x 50 x 2.5 ANGLE 50 x 50 x 2.5 ANGLE 0.42 TRIMDEK COLOURBOND 0.42 TRIMDEK COLOURBOND Z15015 Z15015 C15015 100 X 100 X 2 RHS 65NB PIPE

PRICE'S FABRICATION AND STEEL LOT 200 ALBANY HWY WILLIAMS Phone 98309414 Email barry@pricesfabricationandsteel.com.au	Drawing 1 Scale 1:50	NARROGIN RACE CLUB LOT 1561 CLAYTON ROAD NARROGIN 6312
	5/12/18 ISSUED FOR APPROVAL	

DAN TURNER BE (CIVIL) REG 05707
Civil, Structural & Project Management
ABN: 37 730 733 802
97 Felspar St Narrogin WA 6312
Ph (08) 9881 3218 Mob 04 0986 7048
Email: dant34175@bigpond.com

[Handwritten Signature]
7 12 18



PRICE'S FABRICATION AND STEEL LOT 200 ALBANY HWY WILLIAMS Phone 98309414 Email barry@pricesfabricationandsteel.com.au	Drawing 2 Scale 1:50	NARROGIN RACE CLUB LOT 1561 CLAYTON ROAD NARROGIN 6312
	5/12/18 ISSUED FOR APPROVAL	

DAN TURNER DE (CIVIL) RPEQ 05707
 Civil, Structural & Project Management
 ABN: 37 730 733 802
 97 Feispar St Narrogin WA 6312
 Ph (08) 9881 3218 Mob 04 0986 7048
 Email: dant34175@bigpond.com

[Handwritten Signature]
 7 12 18

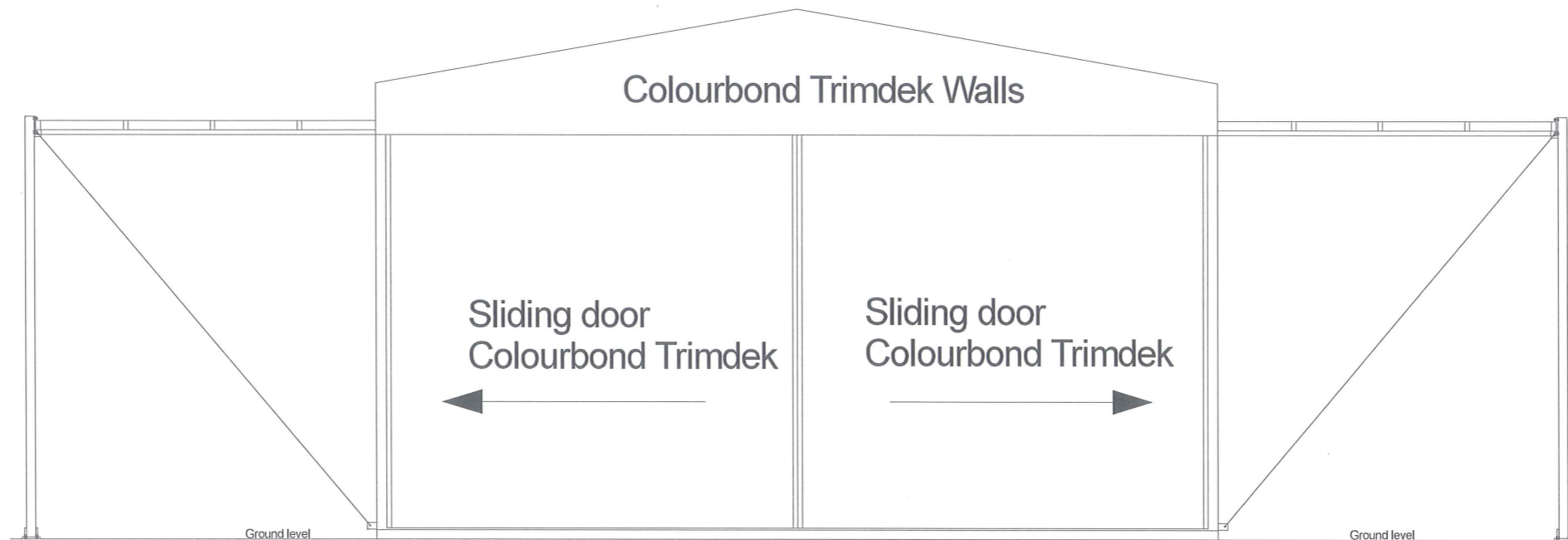

END ELEVATION

PRICE'S FABRICATION AND STEEL LOT 200 ALBANY HWY WILLIAMS Phone 98309414 Email barry@pricesfabricationandsteel.com.au	Drawing 3 Scale 1:50	NARROGIN RACE CLUB LOT 1561 CLAYTON ROAD NARROGIN 6312
	5/12/18 ISSUED FOR APPROVAL	

DAN TURNER BE (Civil) RPEQ 05707
 Civil, Structural & Project Management
 ABN: 37 730 733 802
 97 Felspar St Narrogin WA 6312
 Ph (08) 9881 3218 Mob 04 0986 7048
 Email: dant34175@bigpond.com

[Handwritten signature]
7 12 18

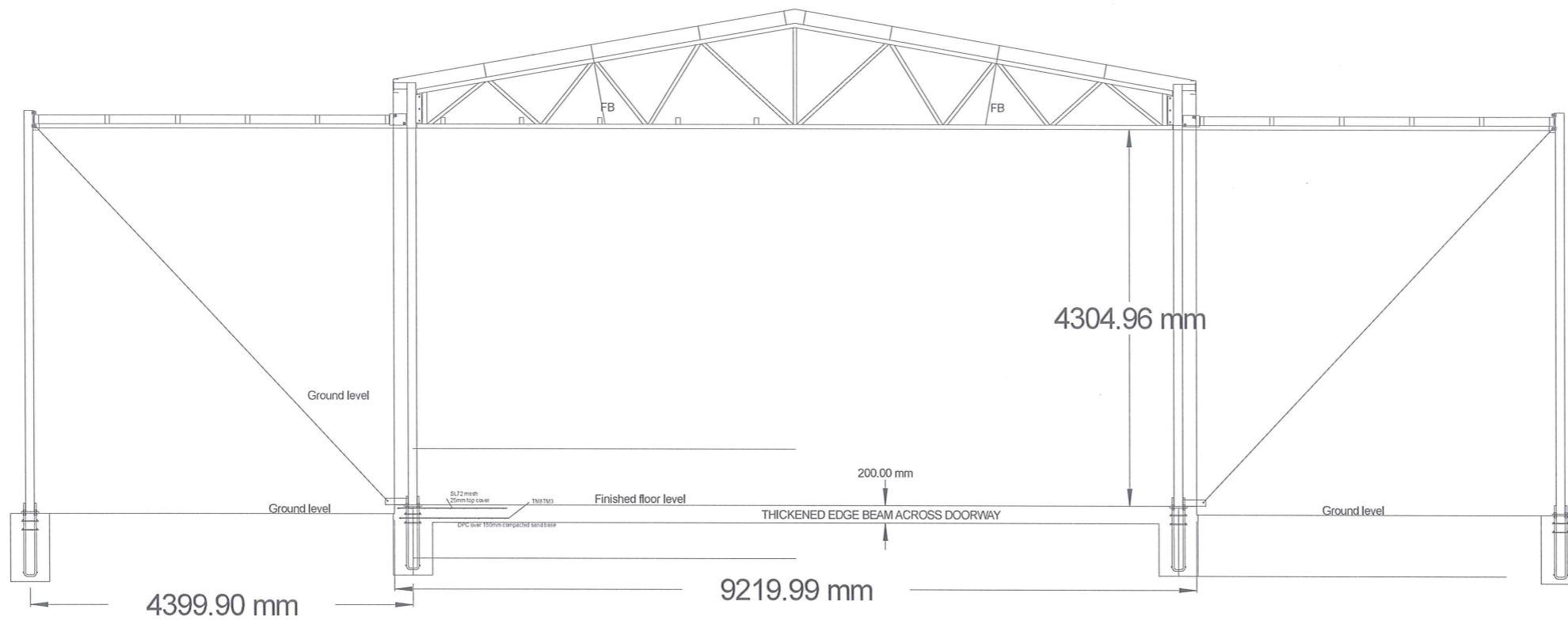

END ELEVATION

PRICE'S FABRICATION AND STEEL LOT 200 ALBANY HWY WILLIAMS Phone 98309414 Email barry@pricesfabricationandsteel.com.au	Drawing 4 Scale 1:50	NARROGIN RACE CLUB LOT 1561 CLAYTON ROAD NARROGIN 6312
	5/12/18 ISSUED FOR APPROVAL	

DAN TURNER BE (CIVIL) REG 05707
 Civil, Structural & Project Management
 ABN: 37 730 733 802
 97 Felspar St Narrogin WA 6312
 Ph (08) 9881 3218 Mob 04 0986 7048
 Email: dant34175@bigpond.com

[Handwritten signature]
7 12 18

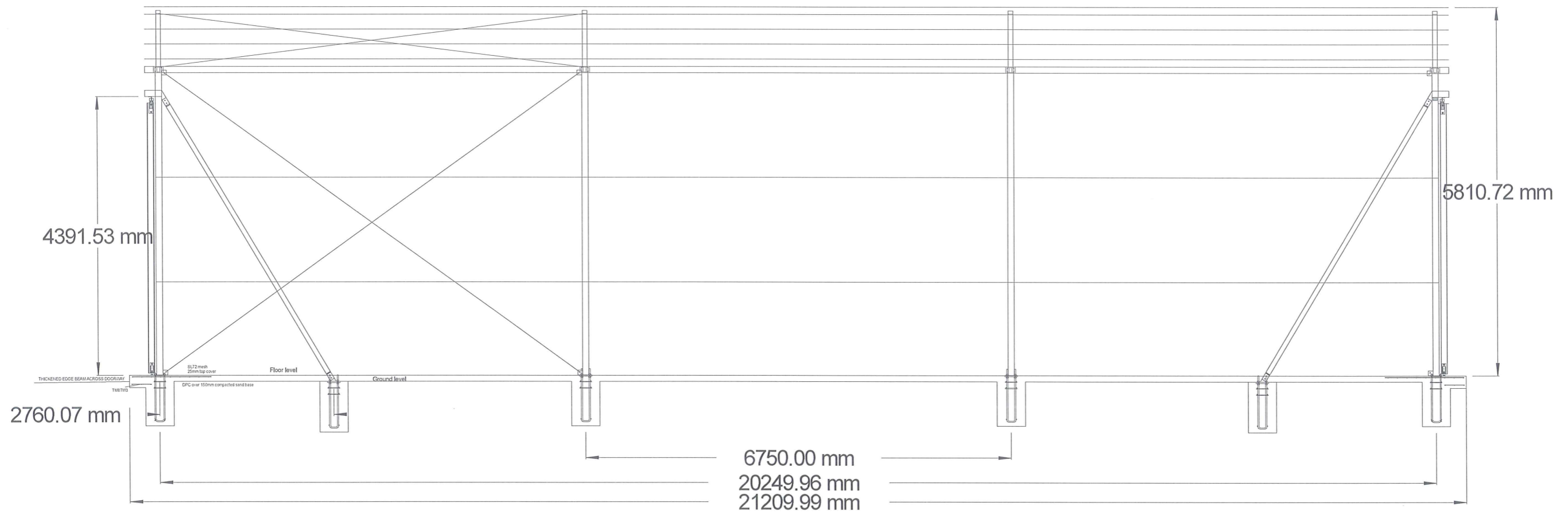

EAST ELEVATION

<p>PRICE'S FABRICATION AND STEEL</p> <p>LOT 200 ALBANY HWY WILLIAMS Phone 98309414 Email barry@pricesfabricationandsteel.com.au</p>	<p>Drawing 5 Scale 1:50</p>	<p>NARROGIN RACE CLUB LOT 1561 CLAYTON ROAD NARROGIN 6312</p>
	<p>5/12/18 ISSUED FOR APPROVAL</p>	

DAN TURNER BE (Civil) RPEQ 05707
Civil, Structural & Project Management
ABN: 37 730 733 802
97 Felspar St Narrogin WA 6312
Ph (08) 9881 3218 Mob 04 0986 7048
Email: dant34175@bigpond.com

Dan Turner
5/12/18

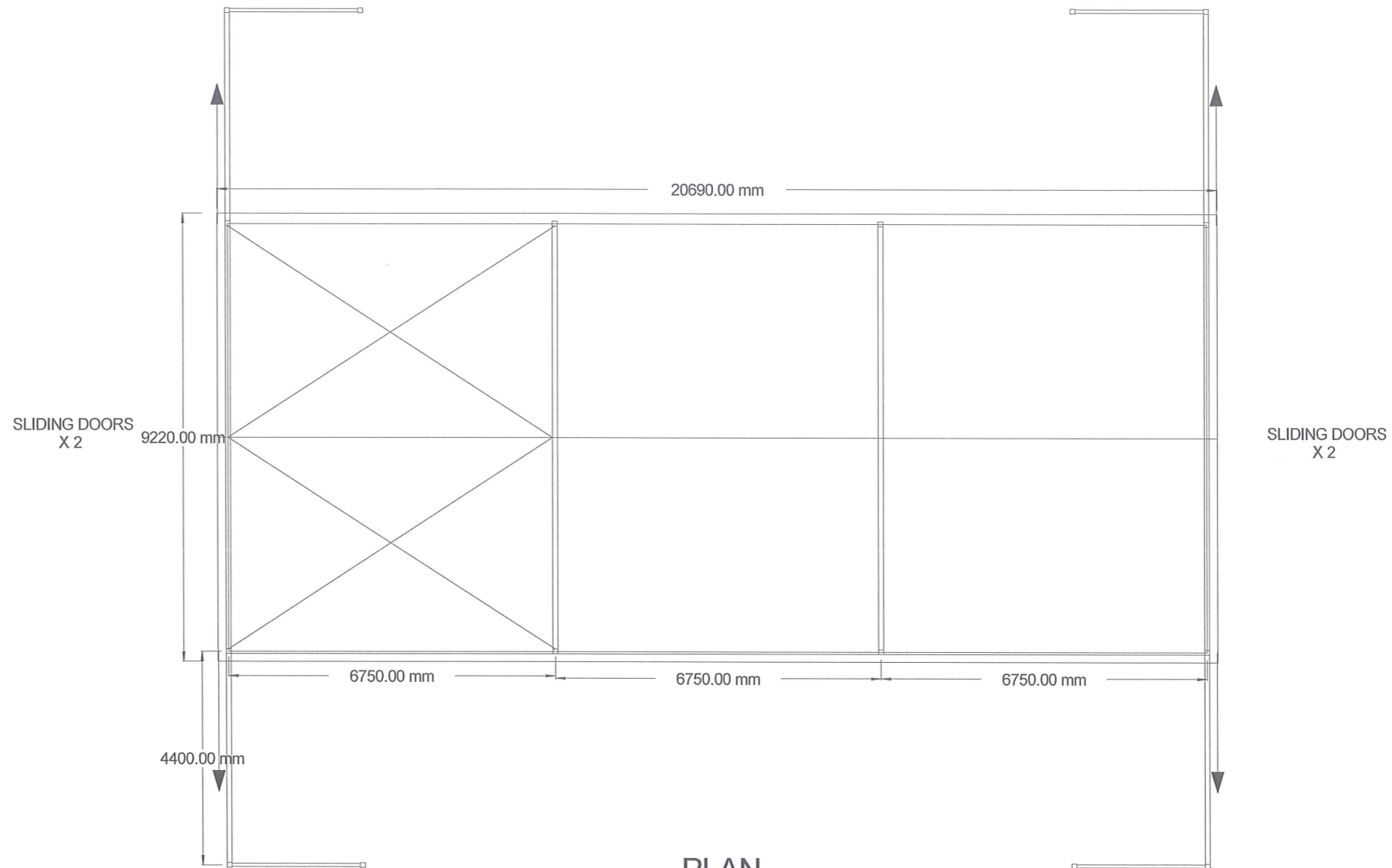

PLAN

PRICE'S FABRICATION AND STEEL LOT 200 ALBANY HWY WILLIAMS Phone 98309414 Email barry@pricesfabricationandsteel.com.au	Drawing 6 Scale 1:50	NARROGIN RACE CLUB LOT 1561 CLAYTON ROAD NARROGIN 6312
	5/12/18 ISSUED FOR APPROVAL	

DAN TURNER BE (CIVIL) RPEQ 05707
 Civil, Structural & Project Management
 ABN: 37 730 733 802
 97 Felspar St Narrogin WA 6312
 Ph (08) 9881 3218 Mob 04 0986 7048
 Email: dant34175@bigpond.com

[Handwritten signature]
7 12 18

Typical footing detail

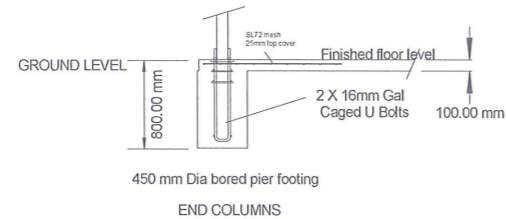

Doors bottom track detail

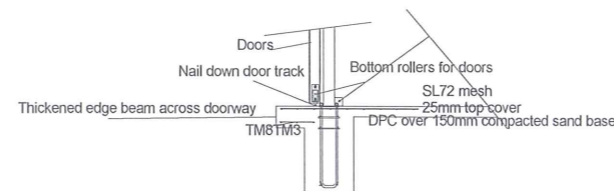

Doors top track detail

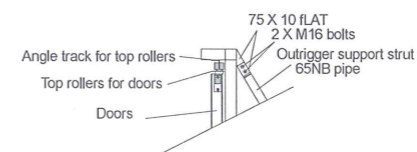

Truss to column detail

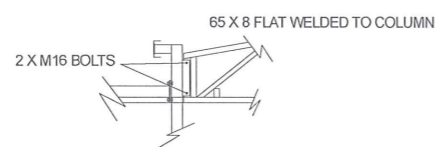

Fly brace detail

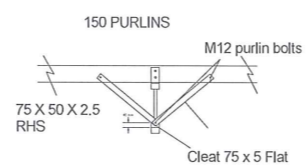

Outrigger footing detail

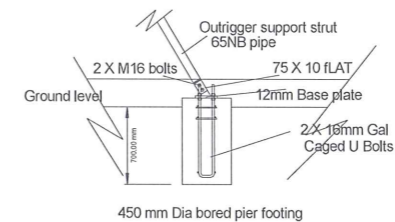

<p>PRICE'S FABRICATION AND STEEL</p> <p>LOT 200 ALBANY HWY WILLIAMS Phone 98309414 Email barry@pricesfabricationandsteel.com.au</p>	<p>Drawing 7 Scale 1:50</p>	<p>NARROGIN RACE CLUB LOT 1561 CLAYTON ROAD NARROGIN 6312</p>
	<p>5/12/18 ISSUED FOR APPROVAL</p>	





DAN TURNER BE (CIVIL) RPEQ 05707
Civil, Structural & Project Management
ABN: 37 730 733 802
97 Felspar St Narrogin WA 6312
Ph (08) 9881 3218 Mob 04 0986 7048
Email: dant34175@bigpond.com

Handwritten signature and date: 5/12/18

Untitled Map

Write a description for your map.

Legend

-  Duke of York Hotel
-  Feature 1
-  Feature 2
-  Ingrey Nissan
-  Narrogin



DAN TURNER BE (Civil) RPEQ 05707
Civil, Structural & Project Management
ABN: 37 730 733 802
97 Felspar St Narrogin WA 6312
Ph (08) 9881 3218 Mob 04 0986 7048
Email: dant34175@bigpond.com

Handwritten blue ink:
7 12 18

Proposed Shed location

Google Earth



20+ 21

Eric Anderson

From: Narrogin Racing <narroginracing@gmail.com>
Sent: Friday, 7 December 2018 2:04 PM
To: Eric Anderson
Subject: shed

Good afternoon Eric,

Shed has been adjusted and will be Colourbond not Zinc alumin.

Thank you.

Kind regards,

Cathi Trefort-Budby

Manager
Narrogin Racing
ph 98811009
fax 98815823
mobile 0447 066 703

<http://www.narroginracing.com.au/index.php>

Narrogin Leisure Complex Equine Facilities

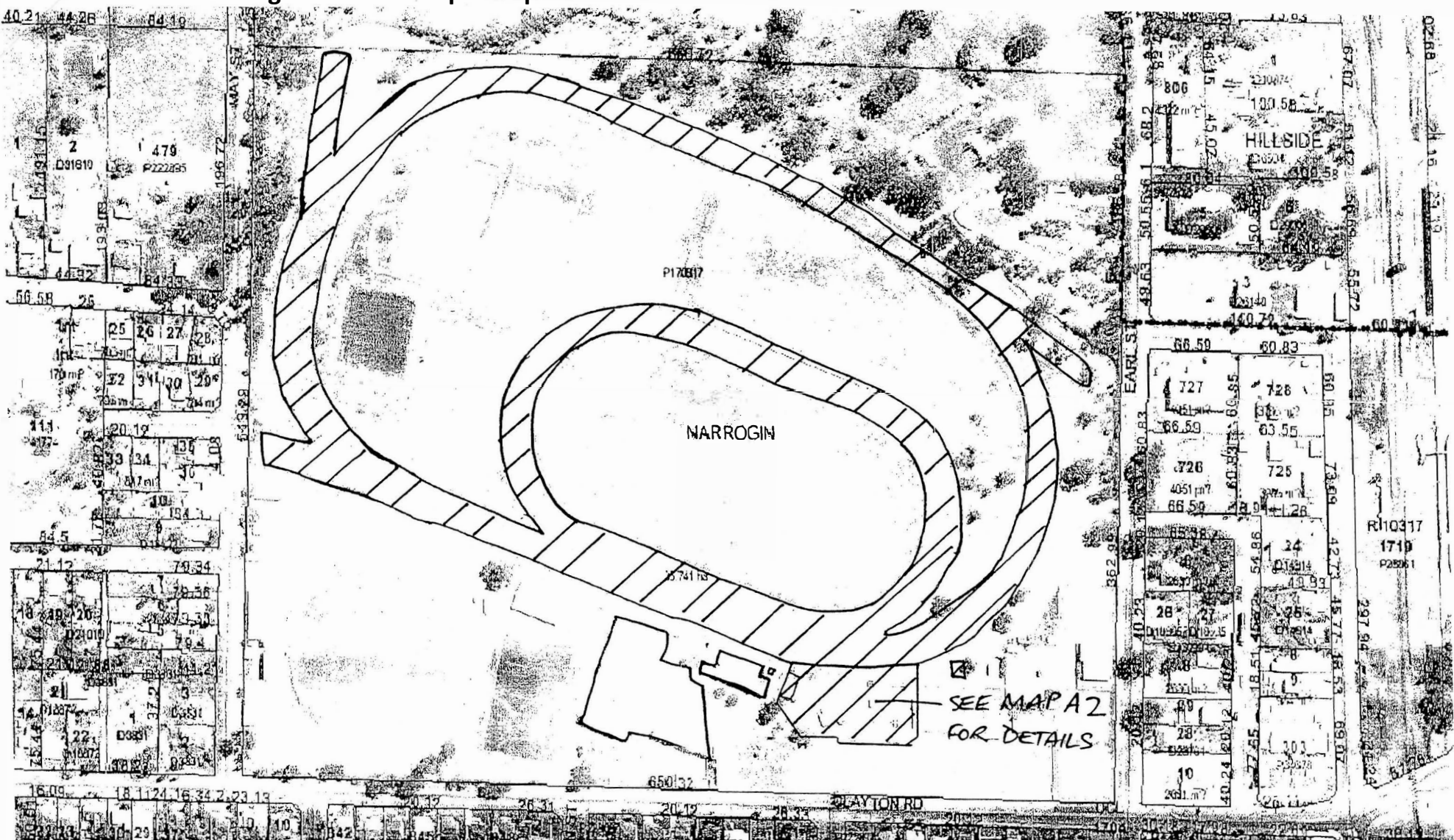

 LEASED AREA

41

Narrogin Leisure Complex Equine Facilities

A2

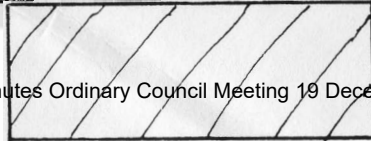
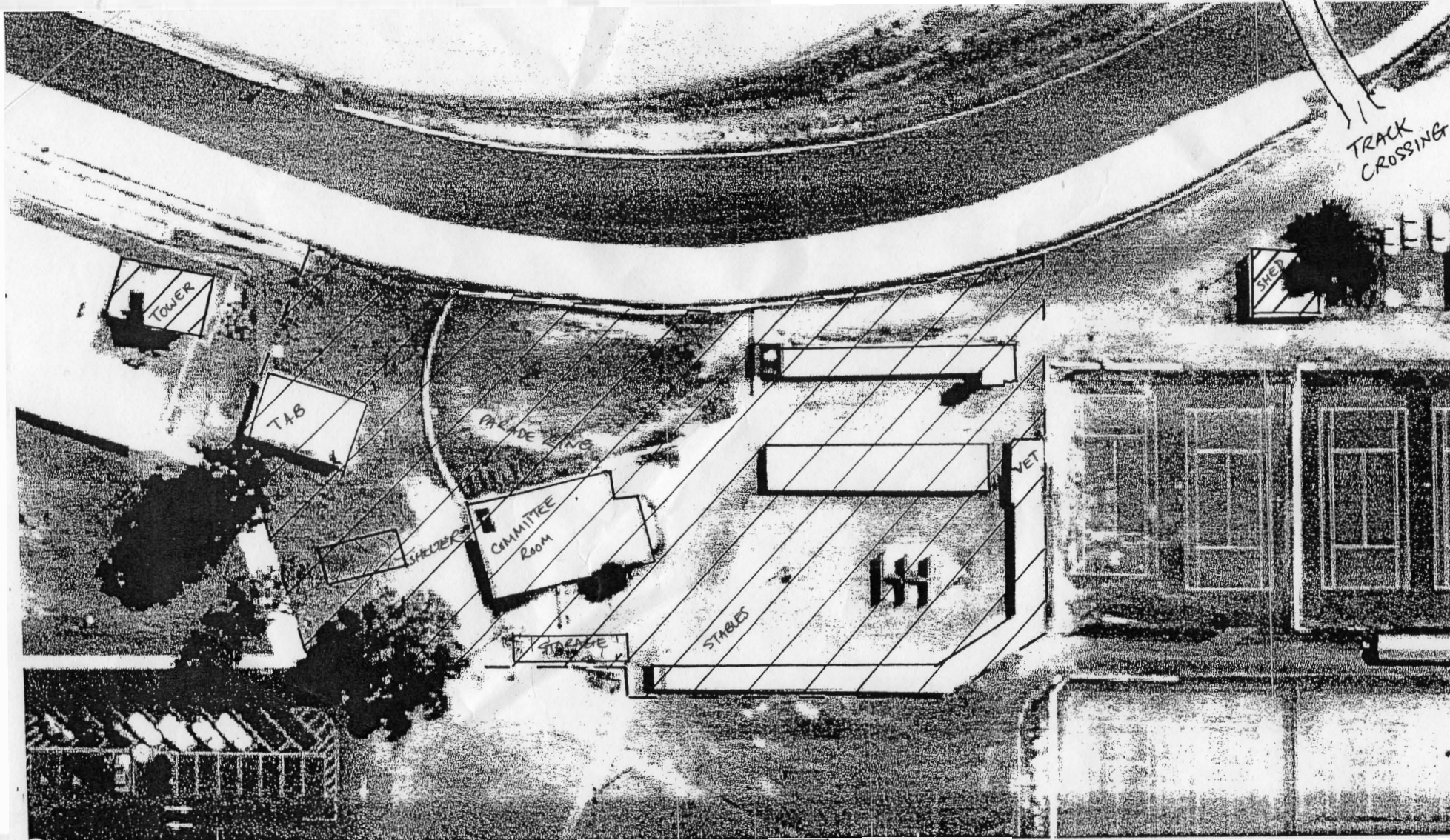

LEASED AREA

10.1.2 LANDFILL TIP PASSES - LOT 1633 (RESERVE 8410) WHITE ROAD, NARROGIN

File Reference	A325100
Disclosure of Interest	Neither the Author nor Authorising Officer have any Impartiality, Financial or Proximity Interest that requires disclosure.
Applicant	Shire of Narrogin
Previous Item Numbers	Nil
Date	26 November 2018
Author	Azhar Awang – Executive Manager Development and Regulatory Services
Authorising Officer	Dale Stewart – Chief Executive Officer
Attachments	Nil

Summary

Council's consideration is requested in regards to the current practice of issuing tip passes to Shire of Narrogin rate payers to allow access to the landfill site.

Background

The Shire of Narrogin currently provides tip passes (general and green waste) to its rate payers, free of charge, to access the Narrogin Landfill site. The tip pass card for green waste entitles the rate payers to access the landfill site nine (9) times annually without charge and the general waste card provides the rate payers with six (6) tip passes, one (1) tip pass for the disposal of a passenger car tyre and one (1) tip pass for the disposal of one (1) car battery.

Currently tip passes are issued with the annual rates notice at the following rate:

- Residential properties – 1 General Waste card and 1 Green Waste card;
- Commercial/Industrial – 1 General Waste card;
- Vacant Land - No tip pass issued;
- Non Rateable/Special use – 1 General waste card; and
- Former Shire Rate Payers – 2 General Waste cards and 1 Green Waste card.

Any additional tip pass cards are charged for at the following rates:

- General waste (\$93)
- Green waste (\$52)

The Shire of Narrogin currently provides for domestic waste kerbside collection for its Town site area every week and recycle kerbside collection every fortnight. This is contracted out to Great Southern Waste Disposal.

Since the former Shire rate payers outside of the Highbury town site and rural residential subdivisions do not have kerbside collection, administratively it was agreed to provide the former Shire rate payers

with two (2) general waste tip passes and, if they were to run out of tip passes, they could come to the Administration building and ask for additional tip passes without incurring additional costs consistent with past practices. Their details are registered to provide data at the end of the year to determine how many of the former Shire rate payers had requested additional tip passes.

Comment

Tip passes have regularly been causing an issue with the Administration due to the number of inconsistencies in existing practices and the different requirements that applied to the former Shire and Town rate payers, commercial and residential properties and non-profit organisation regarding access and the number of tip passes they are entitled.

A meeting was subsequently held between the Shire's Chief Executive Officer (CEO) and staff from the Corporate and Community Services and Development and Regulatory Services departments to discuss this matter. The following points outline some of the matters that were discussed.

Issues

Every year the Shire receives complaints from some rate payers that they have not received their tip passes, due to loss of tip passes or disposed in error, returned mail, undelivered or change of ownership.

The predominant complaint that the Administration receives, is from residents who have not received tip passes from landlords for a variety of reasons.

Other issues relate to charging and methods of payments, such as raising of invoices for small amounts resulting in invoices being issued with little chance of recovery. This results in the need for debt recover of amounts, on average, of \$16. The administrative time involved in raising invoices, following up for non payment and writing off unrecoverable amounts has proved problematic.

The Shire also receives complaints from commercial owners as to why they are not provided with recycling or green waste tip passes. As they are a commercial entity, the recycling and green wastes are undertaken by contractors and therefore is not being subsidised by the Shire's rate payers.

The tip passes are collected at the entry of the landfill site by the gate attendant. Every month these tip passes are collected and collated by the Shire's Environmental Health Officer for recording. This is to assist in measuring the estimated volume of waste that is disposed in our landfill site as part of the licensing requirement. It is intended that the gate attendant will collect the required information manually on a daily log sheet.

Additional Tip Passes

In the previous financial year, 31 additional tip pass cards for general waste were issued of which three (3) residents/rate payers claimed three (3) additional tip passes during the year. A total of six (6) tip passes for green waste were issued.

Costs

The Shire's Administration had costed the printing of the tip passes at \$3,500 per annum. In the 2017/2018 financial year a total of \$1,385.40 was received for the additional tip passes and a total of \$559.35 were received for Green waste. In total, \$1,944.75 was generated as an income for the purchase of the additional tip passes.

There were also costs associated with the administration of the tip passes which have not been taken into consideration.

In conclusion, the cost of administrating the tip passes is not a viable proposition and it is recommended that Council does not continue with issuing tip passes to the residential or commercial rate payers or residents of the Shire and provide 'locals' with free access to the landfill site if the delivered capacities are less than 1m³. However, it is intended that all commercial operators that deliver capacities greater than 1m³ will continue to pay a fee to access the landfill as per the current arrangements.

It is proposed that the definition of 'local' be a resident or rate payer who can provide proof of owning land or residential status, such as a rate notice, vehicle registration plate being a NGN or NO or driver's licence with a Shire of Narrogin address. In addition, most of the residents/rate payers of the Shire are known to the gate attendant. In cases of unknown identity proof of residence will be requested.

Consultation

A meeting was held with the Shire's CEO, Corporate and Community Services and Development and Regulatory Services staff.

Statutory Environment

Waste Avoidance and Resource Recovery (WARR) Act 2007, the WARR Regulations 2008 and the WARR Levy Regulations 2008. The Narrogin waste landfill facility licence sets out conditions that the facility needs to adhere to as issued by the Department of Water and Environmental Regulation.

Environmental Protection Act 1986

This Act provides for waste avoidance and resource recovery, the establishment of a waste authority, provision of waste services by local government, provides for levies on waste and related consequential matters.

Policy Implications

Nil

Financial Implications

The purchase of additional tip passes are set in the Shire's Annual Schedule of Fees and Charges. Based on the income generated for the 2017/2018 budget year, a total of \$1,944.75 for the purchase of additional tip passes. This is less than the cost for the printing (\$3,500) of the tip passes.

Strategic Implications

Shire of Narrogin Strategic Community Plan 2017-2027	
Objective	3. Environment Objective (Conserve, protect and enhance our natural and built environment)
Outcome:	3.2 Effective waste service
	3.3 Efficient use of resources
Strategy:	3.2.1 Support the provision of waste services
	3.3.1 Increase resource usage efficiency

Voting Requirements

Simple Majority

OFFICER'S RECOMMENDATION

That, with respect to the tip passes to the Shire of Narrogin landfill site located at Lot 1633 (Reserve 8410) White Road Narrogin, Council, effective from the commencement of the 2019/20 financial year:

1. Support the proposal to discontinue the practice of issuing tip passes to residents of the Shire of Narrogin;
2. Approve free access for rate payers and residents who deliver capacities less than 1m³ to the refuse site, subject to proof of rate payer or residential status in the Shire of Narrogin with proof being demonstrated via an acceptable process such as, Shire of Narrogin registration plates, rate notice or driver's licence;
3. Publicly advertise the change of arrangements;
4. Note that free waste disposal is not applicable to commercial businesses delivering capacities greater than 1m³ and costs will apply for the disposal of waste at the landfill site in accordance with the Shire's adopted annual fees and charges.

COUNCIL RESOLUTION 1218.126

Moved: Cr G Ballard

Seconded: Cr Bartron

That, with respect to the tip passes to the Shire of Narrogin landfill site located at Lot 1633 (Reserve 8410) White Road Narrogin, Council, effective from the commencement of the 2019/20 financial year:

1. Support the proposal to discontinue the practice of issuing tip passes to residents of the Shire of Narrogin;
1. Approve free access for rate payers and residents who deliver capacities less than 1m³ to the refuse site, subject to proof of rate payer or residential status in the Shire of Narrogin with proof being demonstrated via an acceptable process such as, Shire of Narrogin registration plates, rate notice or driver's licence;
2. Publicly advertise the change of arrangements inclusive of the charges that will apply with respect to tyres and batteries;
3. Note that free waste disposal is not applicable to commercial businesses delivering capacities greater than 1m³ and costs will apply for the disposal of waste at the landfill site in accordance with the Shire's adopted annual fees and charges.

Advice Note:

It was noted that officers would review the contractual arrangements with respect to disposal of car batteries and whether the current adopted fee related to the cost of receipt.

CARRIED 8/0

7:32 pm – Cr Fisher declared a financial interest in the following item and left the meeting.

10.1.3 APPLICATION FOR ANNUAL RENEWAL – TEMPORARY MOBILE CONCRETE BATCHING PLANT AT LOT 5 EARL STREET, NARROGIN

File Reference	A674
Disclosure of Interest	Neither the Author nor Authorising Officer have any Impartiality, Financial or Proximity Interest that requires disclosure.
Applicant	Paul Sims
Previous Item Numbers	Item 10.1.109, 13 September 2016 Resolution. 0817.33 Item 10.1.151, 20 December 2016 Resolution. 1216.186 Item 10.1.122, 20 December 2017 Resolution. 1217.139
Date	10 December 2018
Author	Eric Anderson – Planning Officer
Authorising Officer	Azhar Awang – Executive Manager Development and Regulatory Services
Attachments 1. Locality Plan 2. Application for annual renewal	

Summary

Council is requested to consider the annual renewal for the temporary mobile concrete batching plant at Lot 5 Earl Street, Narrogin, which is now in its third year of its five year approval.

Background

At the Ordinary Council Meeting held 20 December 2016, Council resolved to approve the temporary mobile concrete batching plant at Lot 5 Earl Street, Narrogin, subject to complying with the original conditions as follows:

“Grant Planning Approval for the proposed Temporary Mobile Concrete Batching Plant at Lot 5 Earl Street, Narrogin subject to the following conditions:

- 1. The approval is for a twelve (12) months period from the date of this approval an annual extension to be considered by Council for up to five (5) years.*
- 2. All buildings and structures on site are to comply with the required boundary setback distances as stipulated in the Shire of Narrogin Town Planning Scheme No. 2 (The front setback shall be not less than 11 metres, the rear shall not be less than 10 metres, and the side setbacks shall not be less than 5 metres on one side).*

3. *The applicant is to submit a dust management plan prior to commencing any work on site to the satisfaction of the Shires Chief Executive Officer and the Department of Environment and Regulation.*
4. *Parking bays and ground treatment are to be installed to the satisfaction of the Shire of Narrogin Chief Executive Officer within three months of the date of the Planning Approval prior to the commencement of operation.*
5. *All stormwater and drainage runoff is to be contained on site or connected to the Shires stormwater legal point of discharge prior to the commencement of operation.*
6. *The development approved shall be in accordance with the plans and specification submitted with the application and these shall not be altered or modified without the prior written approval of the Shire.*
7. *The premises shall be kept in a neat and tidy condition at all times to the satisfaction of the Shires Chief Executive Officer*
8. *At the conclusion of the approved period, the Concrete Batching Plant is to be removed and the site rehabilitated to the satisfaction of the Shires Chief Executive Officer.*
9. *No onsite work or production of concrete shall commence without the written approval from the Department of Environmental Regulation.*
10. *If any of the conditions are not fulfilled or complied to, Council may revoke its consent or approval.*

Advice to the Applicant

1. *Compliance with the provisions of the Environmental Protection (Concrete Batching and Cement Product Manufacturing) Regulations 1998 Environmental Protection.*
2. *Compliance with the provisions of the Environmental Protection (Noise) Regulations 1997.*
3. *This is not a building licence for which a separate application is required.*
4. *The applicant be advised of the listing of the property as a potential contaminated site and will be required to comply with all obligations in relation to the declaration.”*

This item was subsequently presented to the Ordinary Council Meeting held on the 20 December 2017. At that meeting, it was recommended by the Officer that Council approve the annual renewal subject to the original conditions of the resolution of Council of 20 December 2016 and, in the event that no negative complaints were received within the next year, authorise the Chief Executive Officer delegated authority to determine the annual renewal for the remaining three (3) year term. Council at the meeting held on 20 December 2017 did not support the officer’s recommendation and voted instead for Council to review the renewal in 12 months’ time.

On 2 November 2018 and 15 November 2018 the Shire of Narrogin advised the applicant that an annual request for renewal was required. On 20 November 2018 the Shire of Narrogin received the required application for annual renewal.

Council is therefore requested to consider the annual renewal of the temporary mobile batching plant as per conditions previously approved.

Comment

The annual renewal has been assessed against the conditions of approval upon which it was granted. A site inspection was undertaken on 30 November 2018 by the Shire's Senior Environmental Health Officer and Planning Officer.

Condition of Approval	Officers Comments December 2018
1. The approval is for a twelve (12) months period from the date of this approval and an annual extension to be considered by Council. For up to five (5) years.	Condition fulfilled. The annual extension is currently being presented for Council's consideration, prior to the expiry of the 12 month approval which has been granted. This is the third year of the five (5) year approval.
2. All buildings and structures on site are to comply with the required boundary setback distances as stipulated in the Shire of Narrogin Town Planning Scheme No. 2 (The front setback shall be not less than 11 metres, the rear shall not be less than 10 metres, and the side setbacks shall not be less than 5 metres on one side).	Condition fulfilled. All buildings on site comply with the relevant setback distances.
3. The applicant is to submit a dust management plan prior to commencing any works on site to the satisfaction of the Shires Chief Executive Officer and the Department of Environment and Regulation.	Condition fulfilled. The applicant has submitted a dust management plan to the former Department of Environment and Regulation (DER). DER has responded that the dust impacts have the potential to cause minimal impact.
4. Parking bays and ground treatment are to be installed to the satisfaction of the Shire of Narrogin's Chief Executive Officer within three months of the date of the Planning Approval prior to the commencement of operation.	Condition fulfilled. There is sufficient parking area along the southern boundary of the lot.
5. All storm water and drainage runoff is to be contained on site or connected to the Shire's storm water legal point of discharge prior to the commencement of operation.	Condition fulfilled. On the site inspection undertaken on 30 November 2018 there was no evidence of erosion caused by run-off.
6. The development approved shall be in accordance with the plans and specification submitted with the application and these shall not be altered or modified without the prior written approval of the Shire.	Condition fulfilled. The development was built in accordance with the submitted plans.
7. The premises shall be kept in a neat and tidy condition at all times to the satisfaction of the Shire's Chief Executive Officer.	Condition outstanding. On the site visit undertaken on 30 November 2018, there was a small pile of concrete waste rubble and another pile of plastic packaging. The applicant was advised of the need to remove the aforementioned waste. In the event that the item is supported by Council it is recommended that Council's authorised officers conduct a follow up inspection prior to the granting of renewal.

8. At the conclusion of the approved period, the Concrete Batching Plant is to be removed and the site rehabilitated to the satisfaction of the Shires Chief Executive Officer.	Condition fulfilled. The applicant has requested an annual renewal.
9. No onsite work or production of concrete shall commence without the written approval from the Department of Environmental Regulation.	Condition fulfilled. DER issued a works approval in April 2017.
10. If any of the conditions are not fulfilled or complied to, Council may revoke its consent or approval.	Condition fulfilled subject to point 7. No complaints have been lodged to the shire of Narrogin in the last 12 Months since the matter was last considered by Council.

Consultation

A site visit was undertaken on 30 November 2018 by:

- Planning Officer
- Senior Environmental Health Officer

Statutory Environment

Former Shire of Narrogin Town Planning Scheme No.2

Policy Implications

Nil

Financial Implications

Application for Planning Consent Fee to the value of \$147 has been paid to the Shire of Narrogin.

Strategic Implications

Shire of Narrogin Strategic Community Plan 2017-2027	
Objective	3. Environment Objective (Conserve, protect and enhance our natural and built environment)
Outcome:	3.4 A well maintained built environment
Strategy:	3.4.1 Improve and maintain built environment

Voting Requirements

Simple Majority

OFFICERS' RECOMMENDATION

That, with respect to the Application for Annual Renewal – Temporary Mobile Concrete Batching Plant at Lot 5 Earl Street Narrogin, Council:

1. Support the renewal for a period of 12 months, subject to the original conditions of the Development Approval issued 23 December 2016.
2. In the event that no complaints are received within the 12 months of the annual renewal, authorise the Chief Executive Officer to determine the annual renewal for the remaining two (2) year term, concluding on 22 December 2021 on the same conditions as approved in part 1. above.

Advice Note

The applicant is reminded of the intent of the Council that it will not entertain a further application for this site for this purpose post 2021.

COUNCIL RESOLUTION 1218.127

Moved: Cr Walker

Seconded: Cr Seale

That, with respect to the Application for Annual Renewal – Temporary Mobile Concrete Batching Plant at Lot 5 Earl Street Narrogin, Council:

1. Support the renewal for a period of 12 months, subject to the original conditions of the Development Approval issued 23 December 2016.

Advice Note

The applicant is reminded of the intent of the Council that it will not entertain a further application for this site for this purpose post 2021.

CARRIED 7/0

Reason for change: The Council wanted to ensure that the applicant was clear that the Council has no current intention to consider a development application for the same purpose for the same site post 2021.

The CEO noted that he would ensure that Officers would follow up with an inspection of the property prior to issuing of this approval with respect to condition 7 of the original approval.



Attachment 1 – Locality Plan

20 NOV 2018 A674 IPA1815865

PLANNING CONSENT

89 Earl Street
PO Box 1145
Narrogin WA 6312

(08) 9890 0900

www.narrogin.wa.gov.au
enquiries@narrogin.wa.gov.au

CASHIER HOURS:
8:30am - 4:30pm
MONDAY- FRIDAY

APPLICATION FOR PLANNING CONSENT

TOWN PLANNING SCHEME NO.2
DISTRICT SCHEME

Name of Applicant	Paul Sims
Correspondence Address	P.O. box 495 Narrogin W.A.6312

I hereby apply for planning consent to:

- Use the land described hereunder for the purpose of
Concrete batching plant
- Erect, alter or carry out development on land described hereunder in accordance with the accompanying plans (3 copies attached)

Existing use of land	Concrete batching plant
Approximate cost of proposed development	\$0
Estimated time of completion	Now
No of persons to be housed / employed after completion	2

TITLES OFFICE DESCRIPTION OF LAND**LOCALITY PLAN**

House No		Lot No	5	Location No	
Plan or Diag	29606	Street Name	Earl St		
Certificate of Title	Volume: 2208				Folio:565

LOT DIMENSIONS

Site area	4047 Square metres
Frontage	50.55 Metres
Depth	80.05 metres

AUTHORITY

Applicant's Signature  Date 19/11/2018

NOTE: WHERE THE APPLICANT IS NOT THE OWNER, THE OWNER'S SIGNATURE IS REQUIRED.

NOTE: ALL OWNERS OF THE PROPERTY MUST SIGN THIS APPLICATION FORM. WHERE PROPERTY IS OWNED BY A COMPANY, AT LEAST TWO DIRECTORS OF THE COMPANY MUST SIGN THE APPLICATION.

Owner's Signature..... <i>A Hall</i>	Date
--	------------

NOTE: THIS FORM IS TO BE SUBMITTED IN DUPLICATE, TOGETHER WITH THREE COPIES OF PLANS, COMPRISING THE INFORMATION SPECIFIED IN THE PARTICULARS REQUIRED WITH THE APPLICATION OUTLINED BELOW.

THIS IS NOT AN APPLICATION FOR A BUILDING LICENCE

PARTICULARS REQUIRED WITH APPLICATION FOR BUILDING CONSENT

Where an application involves the erection or alteration of a building or a change in levels of a site, the plans accompanying an application for planning consent shall, unless especially exempt by the Shire:

- a. Indicate the position and describe the existing buildings and improvements on the site and indicate those which are to be removed;
- b. Indicate the position and describe the buildings and improvements proposed to be constructed, their appearance, height and proposed uses in relation to existing and proposed contours;
- c. Indicate the position, type and height of all the existing trees on the site and indicate those to be retained and those to be removed;
- d. Indicate the areas to be landscaped and the location and type of shrubs, trees and other treatment proposed;
- e. Indicate site contours and details of any proposed alteration to the natural contour of the area;
- f. Indicate car parking areas, their layout and dimensions and accessways and the position of existing and/or proposed crossovers; and
- g. Indicate site dimensions and be to metric scale.

OFFICE USE ONLY

File Reference		Application No	
Date Received		Date of Approval / Refusal	
Date of Notice of Decision		Officer's Signature	

8:03 pm – Cr Fisher returned to the meeting.

10.1.4 AUSTRALIA DAY AND HONOURS COMMITTEE TERMS OF REFERENCE - AMENDED

File Reference	26.4.3
Disclosure of Interest	Neither the Author nor Authorising Officer have any Impartiality, Financial or Proximity Interest that requires disclosure.
Applicant	Shire of Narrogin
Previous Item Numbers	Nil
Date	19 December 2018
Author	Loriann Bell – Administration Support Officer Development and Regulatory Services
Authorising Officer	Azhar Awang – Executive Manager Development and Regulatory Services
Attachments	
1. Australia Day and Honours Committee Terms of Reference including: Schedule 1.4 Processes and Criteria; and appendices with Standard Conditions for establishment of Council Committees	

Summary

Council is requested to consider approving a recommendation from the Australia Day and Honours Committee proposing amendments to the Australia Day and Honours Committee Terms of Reference, which include the change of name for the Senior Officer Responsible, from the Manager Leisure and Culture to the Executive Manager Development and Regulatory Services, and increase the number of Community Members from zero to three.

Background

Following the merger of the former Town and Shire of Narrogin in July 2016, the former Australia Day Committee was revoked and replaced with the Australia Day and Honours Committee.

At the Ordinary Council meeting held on 25 October 2016, the Terms of Reference and the Standard conditions for establishment of Council Committees was endorsed by Council. Furthermore, the appointments to the Australia Day and Honours Committee for the period of 25 October 2016 – October 2017 was endorsed by Council at the ordinary Council meeting held on 25 October 2017 with the following composition:

Membership	
Nomination of	No.
Elected members, including ex-officio	2
Employees, including ex-officio	0
Other persons – Community at large	
Lions, Narrogin	1

Rotary, Narrogin	1
Narrogin Residents & Ratepayers Assoc.	1
Total Membership	5
Quorum	3 No additional criteria

Meetings Appendix 1 – Standard conditions for establishment of Council Committees

Administrative Support

Senior Officer responsible	Manager Leisure and Culture
Initial contact person	Administration Support Officer Development & Regulatory Services

The Australia Day and Honours Committee at its meeting of 13 November 2018 resolved as follows:

“That in relation to the proposed amendments to the Australia Day and Honours Committee Terms of Reference and Schedule 1.4 Processes and Criteria the Committee recommends to Council that:

- 1. The name of the Responsible Senior Officer be changed from the Manager Leisure and Culture to, the Executive Manager Development and Regulatory Services:*
- 2. Schedule 1.4 Processes and Criteria is amended to reflect changes to the date of the advertising schedule and the nomination period; and*
- 3. The number of Community Members be increased from zero to three.”*

Comment

The Local Government Act 1995 provides that employee appointments to Council Committees are the prerogative of the CEO who may elect to nominate themselves or another officer at their discretion.

Staff appointments to the Committee are role-specific, and the Senior Officer has responsibility for administering the Committee, overseeing its general operation in accordance with the standard conditions or specific variation as authorised by Council, and ensuring the Committee’s minutes are presented to Council.

Council are asked to support the recommendation to amend the Australia Day and Honours Committee Terms of Reference to record the change of title for the Senior Officer responsible, and recommend that the number of Community Members be increased from zero to three, thereby increasing Committee membership from five to eight and the quorum would increase from three to four.

Committee membership would be as follows:

Membership	
Nomination of	No.
Elected members, including ex-officio	2
Employees, including ex-officio	0
Other persons – Community at large	3
Lions, Narrogin	1

Rotary, Narrogin	1
Narrogin Residents & Ratepayers Assoc.	1
Total Membership	8
Quorum	4 No additional criteria

Meetings Appendix 1 – Standard conditions for establishment of Council Committees

Administrative Support

Senior Officer responsible	Executive Manager Development & Regulatory Services
Initial contact person	Administration Support Officer Development & Regulatory Services

Consultation

- Chief Executive Officer
- Executive Manager Development and Regulatory Services
- Australia Day and Honours Committee

Statutory Environment

Sections 5.8 through to 5.19 of the Local Government Act 1995 relate.

Policy Implications

Nil

Financial Implications

There are no known meaningful financial implications relative to this matter in excess of officer time and minor administrative cost.

Strategic Implications

Shire of Narrogin Strategic Community Plan 2017-2027	
Objective	2. Social Objective (To provide community facilities and promote social interaction)
Outcome:	2.3 Existing strong community spirit and pride is fostered, promoted and encouraged
Strategy:	2.3.2 Engage and support community groups and volunteers
Strategy:	2.3.3 Facilitate and support community events

Voting Requirements

Absolute Majority

COMMITTEE RECOMMENDATION

That in relation to the proposed amendments to the Australia Day and Honours Committee Terms of Reference and Schedule 1.4 Processes and Criteria the Committee recommends to Council that:

1. The name of the Responsible Senior Officer be changed from the Manager Leisure and Culture to, the Executive Manager Development and Regulatory Services:
2. Schedule 1.4 Processes and Criteria is amended to reflect changes to the date of the advertising schedule and the nomination period; and
3. The number of Community Members be increased from zero to three.

Or

OFFICERS' RECOMMENDATION AND COUNCIL RESOLUTION 1218.128

Moved: Cr Seale

Seconded: Cr Ward

That, in relation to the proposed amendments to the Australia Day and Honours Committee Terms of Reference and Schedule 1.4 Processes and Criteria, Council:

1. Approve the Responsible Officer to be the Executive Manager Development and Regulatory Services;
2. Amend Schedule 1.4 Processes and Criteria to reflect changes to the date of the advertising schedule and the nomination period;
3. Increase the Committee membership from five (5) to eight (8);
4. Increase the quorum from three (3) to four (4);
5. Increase the number of Community Members from zero (0) to three (3) and advertise for nominees.

**CARRIED 8/0
BY ABSOLUTE MAJORITY**

1.4 Draft Amendment - Australia Day and Honours Committee Terms of Reference

Statutory context Appendix 1 – Standard conditions for establishment of Council Committees

Council context Appendix 1 – Standard conditions for establishment of Council Committees

History

Established	25 October 2016
Amended	20 December 2016

Establishment

Objectives To provide an avenue of communication/consultation between Council and the community for:

- Australia Day WA Citizen of the Year Awards in each category determined by it;
- Shire of Narrogin Australia Day Awards, consistent with the Australia Day WA Citizen of the Year Awards eligibility criteria and such other local award deemed appropriate by the Shire;
- Shire of Narrogin Australia Day functions and events; and
- other Commonwealth, State or local awards or honours.

Membership

Nomination of	No.	
Elected members, including ex-officio	2	
Employees, including ex-officio	0	
Other persons – Community at large	3	
Other community nominated by		
- Lions, Narrogin	1	
- Rotary, Narrogin	1	
- Narrogin Residents & Ratepayers Assoc.	1	
Total Membership	8	
Quorum	4	No additional criteria

Meeting Appendix 1 – Standard conditions for establishment of Council Committees

Administrative Support

Senior Officer responsible	Executive Manager Development & Regulatory Services
Initial contact person	Administration Support Officer Development & Regulatory Services

Role and Scope of Committee

1. To promote the Australia Day, Australia Day WA Citizen of the Year Awards and Shire of Narrogin Australia Day Awards and make recommendations to Council based on nominations received from the community.
2. To recommend to Council nomination of community members for recognition in:
 - Australian Honours;
 - National or State Australia Day Awards; and
 - Other recognition or honours considered appropriate.

3. To consider community requests for Council support of nominations for Commonwealth or State awards or honours.
4. To promote the Shire's Australia Day event within the wider community with due consideration and respect for the needs and views of all members of the community.
5. To give consideration to, and make decisions regarding the venue, program/format, menu and layout of tables/seating and decorations.

– *End of TOR*

Notes

DRAFT

Terms of Reference Schedule 1.4 – Honours and Awards Processes and Criteria

1. The Australia Day WA Citizen of the Year Awards foster, recognise and celebrate significant contributions to community life and active citizenship in the Shire of Narrogin in the following categories:
 - a) Citizen of the Year;
 - b) Citizen of the Year (Youth);
 - c) Citizen of the Year (Senior); and
 - d) Active Citizenship (Group or Event).
2. The Committee is to coordinate and consider:
 - a) community nominations for the Australia Day WA Citizen of the Year Awards;
 - b) Shire of Narrogin Awards consistent with the Australia Day Citizen of the Year Awards, and in exceptional circumstances, other recognition as appropriate; and
 - c) in exceptional circumstances, any other Commonwealth, State or local award or honours.
3. The Shire will invite Australia Day WA Citizen of the Year Awards nominations from community groups and private citizens.
4. Australia Day WA Citizen of the Year Awards nominations will open on 1 September and close on 31 October.
5. Australia Day WA Citizen of the Year Awards nominations will be advertised:
 - a) in the Narrogin Observer in mid-August and again in mid-September, and
 - b) on the Shire's website and Facebook page.
6. Late nominations for Awards will not be accepted.
7. Award recipients will be considered by the Australia Day and Honours Committee.
8. The Committee is to make its recommendations to the Council Meeting held in November whose decision will be final.
9. Nomination forms are to have a nominator as well as another person to support the nomination;
10. The award recipients will be judged to have shown active citizenship and:
 - a) Made significant contribution to the local community.
 - b) Demonstrated leadership on a community issue resulting in the enhancement of community life.
 - c) Made a significant initiative which has brought about positive change and added value to community life.
 - d) Demonstrated inspiring qualities as a role model for the community.
11. Eligibility Criteria:
 - a) A person who does not reside within the Shire of Narrogin is eligible to receive an award;
 - b) Awards may be granted posthumously in recognition of recent achievements;
 - c) Groups of people will not normally be eligible except when meeting the criteria for a community group;
 - d) A person cannot receive the same award twice, but can be considered for another award;
 - e) Unsuccessful nominees may be re-nominated in future years;
 - f) Self-nominations are not eligible; and
 - g) Sitting members and employees of Commonwealth, State and Local Government are not eligible for nomination relating to their service as an elected member or employee, but may be considered for nomination in their private capacity.
12. Awards will be presented at the Australia Day Community Event on 26 January annually.
13. Awards and Honours other than Australia Day WA Citizen of the Year Awards may be considered by the Committee at any time throughout the year, following the general principles and procedures above, for presentation at an appropriate function.

- End of Schedule

Appendices

Appendix 1 – Standard conditions for establishment of Council Committees

Unless otherwise specified in the establishment of a Committee or Reference Group, the following standard conditions apply to all.

Matters will only be listed if varying from these Standard Conditions

Statutory context	<p>The majority of Committees are established under the Local Government Act 1995 –</p> <ul style="list-style-type: none">- s.5.8 to s.5.18 – Committees and their meetings.- s.5.19 to s.5.25 – Matters affecting Council and Committee meetings.- s.5.59 to s.5.90 – Financial interests, declarations, gifts etc. <p>Also refer to Local Government (Administration) Regulations 1996 –</p> <ul style="list-style-type: none">- r.4 to r.14B – Committees and committee meetings. <p>Shire of Narrogin Meeting Procedures Local Law 2016, unless otherwise provided for by the Act or Regulations.</p> <p>Some committees, but not all, have statutory functions. If so, general references to legislative requirements are given.</p>
Council context	<p>From time to time, Council may adopt specific policies that affect the Committee or provide direction.</p> <p>Compliance with the Shire of Narrogin Code of Conduct for Council Members, Committee Members and Employees is mandatory, as required by the Act and Regulations.</p>
History	<p>First established Last amended</p>
Establishment	
Objectives	<p>Brief outline of Council's objectives for the Committee.</p>
Authority	<p>Unless provided for by the Act or Regulations, the Committee has an advisory role only, and has no delegated authority to implement actions or activity unless authorised by Council.</p>
Financial Interests	<p>The Act requires all members of the Committee comply with the interest provisions of the Act –</p> <ul style="list-style-type: none">- financial – both direct and indirect interests which impact the member;- proximity – development adjoining or affecting the member;- declarations – written declaration to be made to CEO or presiding members;- gifts – to be notified to CEO within 10 days of receipt or promise of gift.
Working Parties	<p>The Act does not permit the establishment of a sub-Committee, however, the Committee may request that a member or several members consider a particular matter.</p>
Code of Conduct	<p>The Act requires compliance with the Code of Conduct adopted by the Shire of Narrogin.</p>

Membership

Composition The Act requires that a Committee have a membership of at least 3 people.

A vacancy does not reduce the number of positions on the Committee, unless Council resolves by absolute majority. The number of members must be stipulated by Council, and cannot be varied by the Committee. Should there be less members than the number resolved by Council, the position is considered vacant, however, the quorum required is not affected.

The Committee is to comprise of –

- Council members, including ex-officio as permitted by the Act.
- Employees, as resolved by Council, including ex-officio as permitted by the Act. The role of member includes the obligation to vote and is separate from the administrative support function of the Committee.
- Other persons, i.e. community members, either named or by position within an external organisation.

If notified to Council when Committee is established, the President and CEO may exercise separate rights to be a member or nominate another elected member or employee to be a member of the Committee.

The TOR for a Committee does not over-ride a Council resolution.

Members	Council members	As stipulated in the resolution establishing the Committee by absolute majority, or subsequent decision, and including any ex-officio member.
	Employees	As stipulated in the resolution establishing the Committee by absolute majority, or subsequent decision, and including any ex-officio member.
	Other persons	From the community or specific organisation, as stipulated in the resolution establishing the Committee by absolute majority, or subsequent decision.

Only appointed members of a Committee may vote. Generally, staff will not be voting members of a Committee, but have an advisory and support role only. However, there may be exceptions and these will be noted in the individual Committee's Terms of Reference.

Nomination of a member may be –

- by name, in which case the person holds membership until removed, whether a resident, employee or not; or
- by position, in which case the person holding the specific position.

Where a member is appointed by position, a person acting in that position automatically has membership. If the person chooses to delegate the membership to another person within their organisation, this must be notified to the CEO. The person delegated does not automatically become the deputy member.

Deputy members The Act defines “deputy member” as a person appointed by Council authorised to act for a Committee member in that person's unavailability.

Only the person initially present at the meeting may participate, i.e. “tag teaming” by leaving a meeting, allowing the other to participate and vote, is not permitted.

Where a deputy member is appointed by position, a person acting in that position automatically has membership. Where the person chooses to delegate the membership to another person within their organisation, this must be notified to the CEO.

Vacancies	<p>The Act requires that members and deputy members be approved by absolute majority of Council.</p> <p>The Committee is not permitted to co-opt members, but may invite a person or organisation to make a presentation or deputation.</p>
Tenure	<p>The Act stipulates membership of the Committee is until –</p> <ul style="list-style-type: none">• the person no longer holds the office by virtue of which they were appointed,• the person resigns by notice in writing to the presiding member or the CEO,• the person's term of appointment expires or is removed by Council, or otherwise become vacant,• the committee is disbanded or term for which it was established expires. <p>Generally, Council will only appoint an elected member or community member to the same committee for a maximum of 3 consecutive terms (i.e. 6 years).</p> <p>Consistent with the provisions of the Act s.2.25(4) applying to Council members, Council may remove a Committee member who has been absent for 3 consecutive meetings.</p>
Payments	<p>Meeting fees are not paid. In some instances, reimbursement for actual expenses incurred in attending a Committee meeting may be permitted. Refer to CEO.</p>
Meetings	
Frequency	<p>May be specified by Council, but generally as required and determined by the Committee.</p>
Presiding Member	<p>The Act requires that the presiding member be selected by the Committee.</p>
Procedures	<p>In accordance with Shire of Narrogin Meeting Procedures Local Law.</p>
Deputations	<p>In accordance with Shire of Narrogin Meeting Procedures Local Law.</p>
Quorum	<p>The Act stipulates 50% of the designated membership of the Committee whether the position is vacant or not, must be present.</p> <p>Where the membership is an odd number, the quorum is 50% and rounded up, e.g. quorum for a membership of 9 is 5.</p> <p>In some circumstances, Council is permitted by absolute majority to give prior approval for a specific meeting to reduce the quorum required.</p>
Voting	<p>All recommendations are to be by simple majority of Committee members present, The Presiding Members should announce the result of the vote, e.g. 3/1, or 4/0 etc..</p> <p>The Act requires that all Committee members present at the meeting –</p> <ul style="list-style-type: none">• must vote, and

- must vote in such a way that their vote is not secret, i.e. either on the voices or by show of hands.

Therefore the following are not permitted –

- proxy voting – submission of a written vote by another person);
- abstaining from voting – those present are required by the Act to vote;
- secret ballot or drawing of lots or similar.

In the case of equality of voting, the presiding member is to exercise a casting vote.

Observers do not have a right to speak, but may address the meeting at discretion of the presiding member, and are not permitted to vote.

Agendas	To be available 3 days prior to meeting, to Committee members and the public.
Minutes	To be available 5 days after the meeting to Committee members and the public. The Act requires that the minutes of Committee meetings are submitted to Council for noting and to the following Committee meeting for confirmation.
Recommendations	All decisions of the committee are recommendations to Council, and are not to be actioned until authorised by Council, unless the senior officer has existing authority, responsibility or discretion to do so.

Administrative Support

Senior Officer	Has responsibility for the Committee, overseeing its general operation in accordance with these standard conditions or specific variation as authorised by Council, and ensuring the Committee’s minutes are presented to Council. The role does not confer any right to vote.
Contact	Provides administrative support for the Committee at the direction of the senior office. The role does not confer any right to vote.

Role and Scope of Committee

Detailed terms of reference will be given of what is expected of the Committee.

– End of Standard Conditions for TOR

Notes

General notes for guidance, not forming part of the establishment or terms of reference of the Committee.

TOR Schedule 0.1 – Title

Any Schedule will provide detailed instructions or guidance on how the role and responsibilities of the Committee are to be implemented.

– End of Schedule

Appendix 2 – Criteria for community members of Council Committees and Groups

A number of Committees have members from specific community organisations or from the community at large.

For these Committees, Council will seek to appoint community members so that the Committee meetings will consist of members and deputy members having –

- a) demonstrated expertise and knowledge in the particular area of Committee responsibility;
- b) relevant skills and experience to provide independent advice;
- c) current participation with an organisation having similar objectives would be well regarded,
- d) diverse backgrounds and experience, while remaining relevant to the Committee's functions.

Preference will be given to residents who have a detailed knowledge of the district, enabling Committee members to make a positive contribution towards the community.

Non-residents may be appointed by Council, if suitable candidates cannot be established from the community or if it is determined there is specific need or advisability.

Community members of specific organisations will be invited for –

- a) Local Emergency Management Committee
- b) Australia Day and Honours Committee
- c) Narrogin District Townscape Committee
- d) Community Assisted Transport Service Stakeholder Reference Group

In addition, community members at large will be sought for –

- a) Narrogin District Townscape Committee

10.2 TECHNICAL AND RURAL SERVICES

10.2.1 AWARDING OF REQUEST FOR QUOTATION 18/19-10 ROAD PROFILING AND ASPHALT

File Reference	28.1.1
Disclosure of Interest	Neither the Author nor Authorising Officer have any Impartiality, Financial or Proximity Interest that requires disclosure.
Applicant	Shire of Narrogin
Previous Item Numbers	Nil
Date	4 December 2018
Author	John Warburton – Manager Operations
Authorising Officer	Torre Evans – Executive Manager Technical & Rural Services
Attachments	
1. Profiling and Asphalt RFQ 18/19 – 10 Evaluation Matrix. (Confidential separate cover)	
2. Shire of Narrogin Resurfacing Locations	

Summary

Council is requested to consider awarding the Road Profiling and Asphalt Request for Quotation (RFQ) number 18/19–10 to Super Civil, for the sum of \$520,628.64 including GST, for the budgeted asphalt resurfacing works within the 2018/19 Budget.

Background

The 2018/19 budgeted road asphalt resurfacing works (Attachment 2 – Shire of Narrogin Resurfacing Locations) are part of the ongoing maintenance and refurbishments of roads within the Shire and in accordance with Council's adopted Five Year Road Program 2017 - 2022. Consideration was also given to the 2016 TALIS Road Condition Report when nominating roads for asphalt works along with visual inspection and local knowledge from the Shire's Manager Operations.

These works need to be completed by contractors with specialised machinery and expertise. The cost of such works was estimated to exceed the \$150,000 expenditure threshold and therefore necessary for the works to be facilitated through either a RFQ or Request for Tender (RFT) process.

The Road Profiling and Asphalt RFQ was facilitated through the WALGA Preferred Supplier, eQuotes portal which satisfies the Local Government statutory requirement for procurement.

Comment

The RFQ was advertised through the WALGA eQuotes Portal from 7 November 2018 to 21 November 2018. The RFQ document was sent to four WALGA preferred suppliers with two of those companies responding as follows:

- Super Civil
- Roads 2000

The RFQ was evaluated on 80% price, 10% relevant experience and 10% OS&H, with a total weighted score of 100 points being available for compliant submissions.

Super Civil scored 92 points for their submission and Roads 2000 scored 78.3 points for their submission. Both companies supplied all of the relevant documentation that was requested. Both companies are prequalified WALGA preferred suppliers and have relevant experience for these works. Super Civil scored the highest due to their competitive pricing.

Consultation

The RFQ submissions were considered and evaluated by:

- Manager Operations
- Executive Manager Technical & Rural Services
- Technical Officer.

Statutory Environment

- Local Government Act 1995 S3.57 – Tenders for providing goods or services
- Local Government (Functions and General) Regulations 1996 Part 4 – Provisions of Goods and Services, Division 2 – Tenders for Providing Goods and Services (s.3.57).

Policy Implications

Complies with Council Policy – Section 3 Financial Management, 3.1 Purchasing Framework, 3.1(b) Purchasing Thresholds and Requirements, notwithstanding that only two organisations submitted quotes.

It is noted that the procurement was facilitated as a compliant eQuote and not as a Public Tender consistent with Council Policy and Regulations.

Financial Implications

The expenditure is wholly contained within the Budget. See below table:

Road	Budgeted amount for Profiling & Asphalt Component inc. GST	Quoted amount for Profiling & Asphalt inc. GST
Herald Street	\$423,360.00	\$406,897.85
Egerton Street	\$79,860.00	\$78,266.39
Museum Car Park	\$41,225.00	\$35,464.40
Total	\$544,445.00	\$520,628.64

Strategic Implications

Shire of Narrogin Strategic Community Plan 2017-2027	
Objective	1. Economic Objective (Support growth and progress, locally and regionally)
Outcome:	1.3 An effective well maintained transport network
Strategy:	1.3.1 Maintain and improve road network in line with resource capacity

Voting Requirements

Simple Majority.

OFFICERS' RECOMMENDATION AND COUNCIL RESOLUTION 1218.129

Moved: Cr Seale Seconded: Cr Wiese

That, with respect to awarding RFQ 18/19 – 10 Road Profiling and Asphalt, Council:

1. Award the Request for Quote to Super Civil for the amount quoted of \$520,628.64 including GST.
2. Authorise the Chief Executive Officer to execute and manage the contract, including any variations, providing these variations do not exceed the allocated budget provision or reduce the overall scope.

CARRIED 8/0

Shire of Narrogin Resurfacing Locations

Attachment 2

Location of Works	Month	Square Meters	Profiling Y/N	Profiling Depth	Primer Seal Y/N	Asphalt Type (AC)	Asphalt Depth mm
Herald St	January	12,600m2	Yes	30mm	Yes	14mm Black	40mm
Egerton St	January	1,540m2	Yes	30mm	Yes	10mm Black	30mm
Egerton St	January	800m2	Yes			10mm Red	
Museum Carpark	January	635m2	<u>No</u>	<u>Nil</u>	<u>No</u>	10mm Black	30mm
Museum Carpark	January	775m2				10mm Red	

10.3 CORPORATE AND COMMUNITY SERVICES

10.3.1 SCHEDULE OF ACCOUNTS PAID – NOVEMBER 2018

File Reference	12.1.1
Disclosure of Interest	Neither the Author nor Authorising Officer have any Impartiality, Financial or Proximity Interest that requires disclosure.
Applicant	Shire of Narrogin
Previous Item Numbers	Nil
Date	10 December 2018
Author	Agatha Prior – Finance Officer (Creditors)
Authorising Officer	Frank Ludovico – Executive Manager Corporate & Community Services
Attachments	
1. Schedule of Accounts Paid – November 2018 (separate cover).	

Summary

Council is requested to note the payments as presented in the Schedule of Accounts Paid – November 2018.

Background

Pursuant to Local Government Act 1995 Section 6.8 (2)(b), where expenditure has been incurred by a local government, it is to be reported to the next ordinary meeting of Council.

Comment

The Schedule of Accounts Paid – November 2018 is presented to Council for notation. Below is a summary of activity.

November 2018 Payments		
Payment Type	\$	%
Cheque	645.60	0.05
EFT (incl Payroll)	1,193,788.67	96.67
Direct Debit	34,105.39	2.76
Credit Card	3,493.25	0.28
Trust	3,000.00	0.24
Total Payments	1,235,032.91	100

Local Spending Analysis of Total Payments		
Local Suppliers	411,414.15	33.31
Payroll	370,579.15	30.01
Total	781,993.30	63.32

The payment schedule has been provided to Elected Members separately and are not published on the Shire of Narrogin website owing to potential fraudulent activity that can arise from this practice.

Printed copies will be available on request at the Administration building and the Library.

Consultation

Manager Finance

Statutory Environment

Local Government Act 1995 Section 6.8 (2)(b)

Policy Implications

Nil

Financial Implications

All expenditure has been approved via adoption of the 2018/2019 Annual Budget, or resulting from a Council resolution for a budget amendment.

Strategic Implications

Shire of Narrogin Strategic Community Plan 2017-2027	
Objective	4. Civic Leadership Objective (Continually enhance the Shire's organisational capacity to service the needs of a growing community)
Outcome:	4.1 An efficient and effective organisation

Voting Requirements

Simple Majority

<p>OFFICERS' RECOMMENDATION AND COUNCIL RESOLUTION 1218.130</p> <p>Moved: Cr Walker Seconded: Cr Seale</p> <p>That, with respect to the Schedule of Accounts Paid for November 2018, Council note the Report as presented.</p> <p style="text-align: right;">CARRIED 8/0</p>

10.3.2 MONTHLY FINANCIAL REPORTS – NOVEMBER 2018

File Reference	12.8.1
Disclosure of Interest	Neither the Author nor Authorising Officer have any Impartiality, Financial or Proximity Interest that requires disclosure.
Applicant	Shire of Narrogin
Previous Item Numbers	Nil
Date	10 December 2018
Author	Nicole Bryant – Manager Finance
Authorising Officer	Frank Ludovico – Executive Manager Corporate & Community Services
Attachments	1. Monthly Financial Report for the period ended 30 November 2018.

Summary

In accordance with the Local Government Financial Management Regulations (1996), Regulation 34, the Shire is to prepare a monthly Statement of Financial Activity for notation by Council.

Background

Council is requested to review the November 2018 Monthly Financial Reports.

Comment

The November 2018 Monthly Financial Reports are presented for review.

Consultation

Executive Manager Corporate and Community Services.

Statutory Environment

Local Government (Financial Management) Regulations 1996 Regulation 34 applies.

Policy Implications

Nil

Financial Implications

All expenditure has been approved via adoption of the 2018/19 Annual Budget, or resulting from a Council Motion for a budget amendment.

Strategic Implications

Shire of Narrogin Strategic Community Plan 2017-2027	
Objective	4. Civic Leadership Objective (Continually enhance the Shire's organisational capacity to service the needs of a growing community)
Outcome:	4.1 An efficient and effective organisation

Voting Requirements

Simple Majority

<p>OFFICERS' RECOMMENDATION AND COUNCIL RESOLUTION 1218.131</p> <p>Moved: Cr Wiese Seconded: Cr Bartron</p> <p>That, with respect to the Monthly Financial Reports for November 2018, Council note the Reports as presented.</p> <p style="text-align: right;">CARRIED 8/0</p>

MONTHLY FINANCIAL REPORT
(Containing the Statement of Financial Activity)
FOR THE PERIOD ENDED 30 NOVEMBER 2018



TABLE OF CONTENTS

Monthly Summary Information	1 - 2
Statement of Financial Activity	3
Significant Accounting Policies	4
Net Current Assets	5
Material Variances	6
Receivables	7
Capital Acquisitions	8 - 11
Cash Backed Reserves	12
Strategic Projects Tracker	13 - 15

LOCAL GOVERNMENT ACT 1995
LOCAL GOVERNMENT (FINANCIAL MANAGEMENT) REGULATIONS 1996

**MONTHLY FINANCIAL REPORT
FOR THE PERIOD ENDED 30 NOVEMBER 2018**

**MONTHLY SUMMARY
INFORMATION**

PREPARATION TIMING AND REVIEW

Date prepared: All known transactions up to 30 November 2018
Prepared by: Manager of Finance
Reviewed by: Executive Manager of Corporate & Community Svcs

BASIS OF PREPARATION

REPORT PURPOSE

This report is prepared to meet the requirements of Local Government (Financial Management) Regulations 1996, Regulation 34. Note: The Statements and accompanying notes are prepared based on all transactions recorded at the time of preparation and may vary due to transactions being processed for the reporting period after the date of preparation.

BASIS OF ACCOUNTING

This statement comprises a special purpose financial report which has been prepared in accordance with Australian Accounting Standards (as they apply to local governments and not-for-profit entities), Australian Accounting Interpretations, other authoritative pronouncements of the Australian Accounting Standards Board, the Local Government Act 1995 and accompanying regulations. Material accounting policies which have been adopted in the preparation of this statement are presented below and have been consistently applied unless stated otherwise. Except for cash flow and rate setting information, the report has also been prepared on the accrual basis and is based on historical costs, modified, where applicable, by the measurement at fair value of selected non-current assets, financial assets and liabilities.

THE LOCAL GOVERNMENT REPORTING ENTITY

All Funds through which the Council controls resources to carry on its functions have been included in this statement. In the process of reporting on the local government as a single unit, all transactions and balances between those funds (for example, loans and transfers between Funds) have been eliminated. All monies held in the Trust Fund are excluded from the statement.

SIGNIFICANT ACCOUNTING POLICIES

GOODS AND SERVICES TAX

Revenues, expenses and assets are recognised net of the amount of GST, except where the amount of GST incurred is not recoverable from the Australian Taxation Office (ATO). Receivables and payables are stated inclusive of GST receivable or payable. The net amount of GST recoverable from, or payable to, the ATO is included with receivables or payables in the statement of financial position. Cash flows are presented on a gross basis. The GST components of cash flows arising from investing or financing activities which are recoverable from, or payable to, the ATO are presented as operating cash flows.

CRITICAL ACCOUNTING ESTIMATES

The preparation of a financial report in conformity with Australian Accounting Standards requires management to make judgements, estimates and assumptions that effect the application of policies and reported amounts of assets and liabilities, income and expenses. The estimates and associated assumptions are based on historical experience and various other factors that are believed to be reasonable under the circumstances; the results of which form the basis of making the judgements about carrying values of assets and liabilities that are not readily apparent from other sources. Actual results may differ from these estimates.

ROUNDING OFF FIGURES

All figures shown in this statement are rounded to the nearest dollar.

**MONTHLY FINANCIAL REPORT
FOR THE PERIOD ENDED 30 NOVEMBER 2018**

**MONTHLY SUMMARY INFORMATION
GRAPHS**

OPERATING EXPENSES

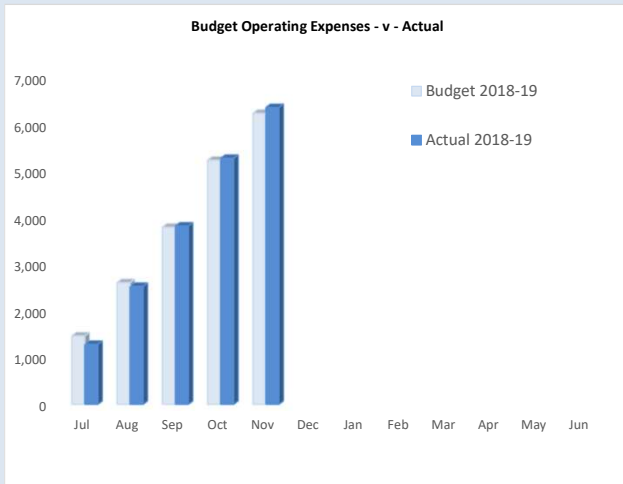

CAPITAL EXPENSES

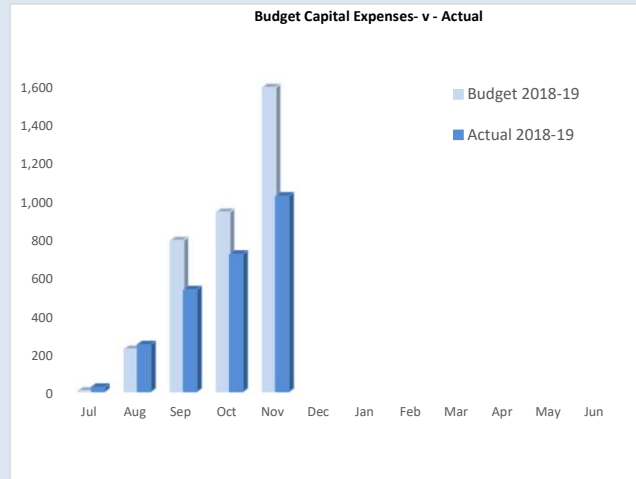

OPERATING REVENUE

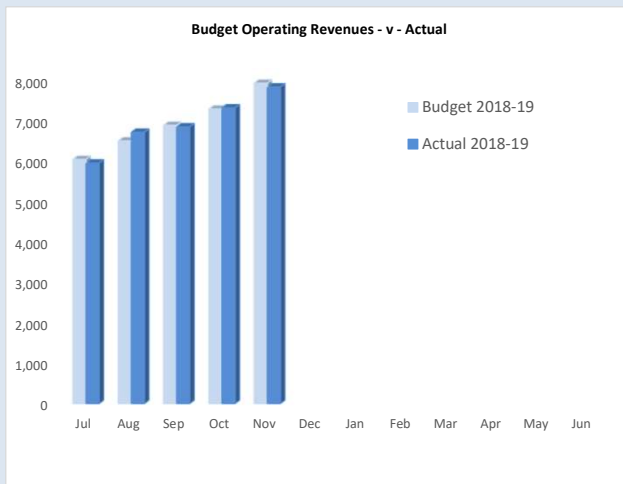

CAPITAL REVENUE

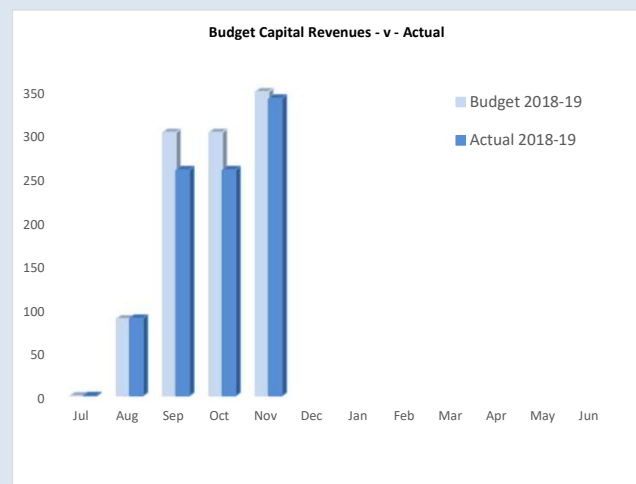

* Budget profiles were not loaded by completion of this report. Budget totals are still to be finalised for Capital *

CAPITAL EXPENSES BY ACTIVITY

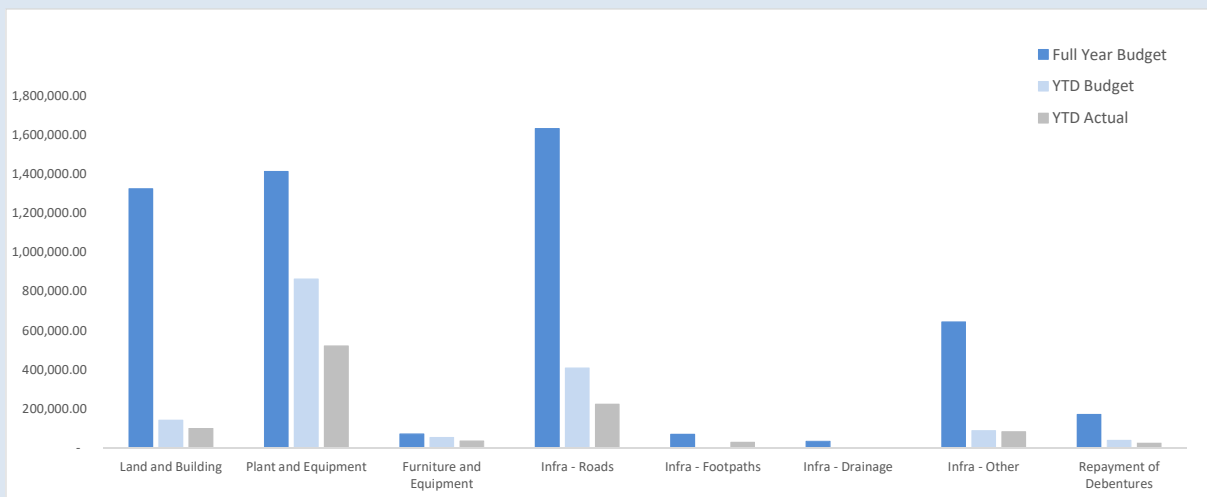

STATEMENT OF FINANCIAL ACTIVITY

STATUTORY REPORTING PROGRAMS

FOR THE PERIOD ENDED FOR THE PERIOD ENDED 30 NOVEMBER 2018

	Adopted Annual Budget	YTD Budget (a)	YTD Actual (b)	Var. \$ (b)-(a)	Var. % (b)-(a)/(a)	Var.
Opening Funding Surplus(Deficit)	\$ 3,686,159	\$ 3,760,640	\$ 3,760,640	\$ 0	% 0%	
Revenue from operating activities						
Governance	5,100	40	2,599	2,559	98%	
General Purpose Funding - Rates	4,788,695	4,788,694	4,698,805	(89,889)	(2%)	
General Purpose Funding - Other	1,285,132	648,784	683,337	34,553	5%	
Law, Order and Public Safety	52,070	28,385	30,630	2,245	7%	
Health	11,500	6,535	12,065	5,530	46%	
Education and Welfare	1,505,434	719,958	655,541	(64,417)	(10%)	
Housing	11,700	4,870	3,596	(1,274)	(35%)	
Community Amenities	1,058,504	933,896	945,866	11,970	1%	
Recreation and Culture	98,854	30,755	91,216	60,461	66%	▲
Transport	924,093	128,382	192,489	64,107	33%	▲
Economic Services	258,407	107,650	118,550	10,900	9%	
Other Property and Services	95,024	39,585	59,139	19,554	33%	▲
	10,094,513	7,437,534	7,493,832	56,299	1%	
Expenditure from operating activities						
Governance	(673,307)	(320,758)	(225,586)	95,172	(42%)	
General Purpose Funding	(277,818)	(94,770)	(99,734)	(4,964)	5%	
Law, Order and Public Safety	(621,664)	(277,614)	(250,561)	27,053	(11%)	
Health	(266,696)	(120,284)	(100,463)	19,821	(20%)	
Education and Welfare	(1,808,377)	(773,555)	(634,471)	139,084	22%	▲
Housing	(34,294)	(16,759)	(10,846)	5,913	55%	
Community Amenities	(1,501,758)	(638,071)	(583,507)	54,564	9%	
Recreation and Culture	(2,893,082)	(1,353,390)	(1,587,661)	(234,271)	(15%)	▼
Transport	(4,440,065)	(2,291,524)	(2,652,868)	(361,344)	(14%)	▼
Economic Services	(664,439)	(293,198)	(286,598)	6,600	2%	
Other Property and Services	(47,778)	(55,260)	75,552	130,812	(173%)	
	(13,229,277)	(6,235,183)	(6,356,742)	(121,559)		
Operating activities excluded from budget						
Add back Depreciation	2,508,848	1,045,295	2,144,306	1,099,011	51%	▲
Adjust (Profit)/Loss on Asset Disposal	123,754	51,560	39,679	(11,881)	(30%)	
Adjust Employee Benefits Provision (Non-Current)	0	0	0	0		
Adjust Deferred Pensioner Rates (Non-Current)	0	0	0	0		
Movement in Leave Reserve (Added Back)	0	0	963	963	100%	
Adjust Rounding	0	0	0	0		
Amount attributable to operating activities	(502,163)	2,299,206	3,322,038	1,022,832		
Investing Activities						
Non-Operating Grants, Subsidies and Contributions	846,982	476,263	323,265	(152,998)	47%	
Purchase of Investments	0	0	0	0		
Land Held for Resale	0	0	0	0		
Land and Buildings	(1,325,039)	(141,331)	(99,523)	41,808	42%	▲
Plant and Equipment	(1,413,335)	(864,030)	(521,665)	342,365	66%	▲
Furniture and Equipment	(71,210)	(52,210)	(35,091)	17,119	49%	▲
Infrastructure Assets - Roads	(1,632,644)	(408,140)	(223,338)	184,802	83%	▲
Infrastructure Assets - Footpaths	(69,000)	0	(28,100)	(28,100)	(100%)	▼
Infrastructure Assets - Road Drainage	(33,589)	(1,598)	(1,100)	498	45%	
Infrastructure Assets - Other	(644,114)	(88,440)	(81,844)	6,596	8%	
Proceeds from Disposal of Assets	742,570	346,859	339,075	(7,784)	(2%)	
Proceeds from Sale of Investments	0	0	0	0		
Amount attributable to investing activities	(3,599,379)	(732,628)	(328,321)	404,306		
Financing Activities						
Proceeds from New Debentures	350,000	0	0	0		
Proceeds from Advances	0	0	0	0		
Repayment of Debentures	(129,977)	(20,285)	(15,925)	4,360	27%	
Self-Supporting Loan Principal	0	0	0	0		
Transfer from Reserves	1,033,367	0	0	0		
Advances to Community Groups	0	0	0	0		
Transfer to Reserves	(838,009)	(5,291)	(9,826)	(4,535)	(46%)	
Amount attributable to financing activities	415,382	(25,576)	(25,751)	(175)		
Net Capital	(3,183,996)	(758,204)	(354,073)	404,131		
Total Net Operating + Capital	(3,686,159)	1,541,002	2,967,965	1,426,963		
Closing Funding Surplus(Deficit)	(0)	5,301,642	6,728,605	1,426,963		

NOTES TO THE STATEMENT OF FINANCIAL ACTIVITY**NET CURRENT ASSETS****FOR THE PERIOD ENDED FOR THE PERIOD ENDED 30 NOVEMBER 2018****SIGNIFICANT ACCOUNTING POLICIES****CURRENT AND NON-CURRENT CLASSIFICATION**

In the determination of whether an asset or liability is current or non-current, consideration is given to the time when each asset or liability is expected to be settled. The asset or liability is classified as current if it is expected to be settled within the next 12 months, being the Council's operational cycle. In the case of liabilities where Council does not have the unconditional right to defer settlement beyond 12 months, such as vested long service leave, the liability is classified as current even if not expected to be settled within the next 12 months. Inventories held for trading are classified as current even if not expected to be realised in the next 12 months except for land held for resale where it is held as non current based on Council's intentions to release for sale.

EMPLOYEE BENEFITS

The provisions for employee benefits relates to amounts expected to be paid for long service leave, annual leave, wages and salaries and are calculated as follows:

(i) Wages, Salaries, Annual Leave and Long Service Leave
(Short-term Benefits)

The provision for employees' benefits to wages, salaries, annual leave and long service leave expected to be settled within 12 months represents the amount the City has a present obligation to pay resulting from employees services provided to balance date. The provision has been calculated at nominal amounts based on remuneration rates the City expects to pay and includes related on-costs.

(ii) *Annual Leave and Long Service Leave (Long-term Benefits)*

The liability for long service leave is recognised in the provision for employee benefits and measured as the present value of expected future payments to be made in respect of services provided by employees up to the reporting date using the project unit credit method. Consideration is given to expected future wage and salary levels, experience of employee departures and periods of service. Expected future payments are discounted using market yields at the reporting date on national government bonds with terms to maturity and currency that match as closely as possible, the estimated future cash outflows. Where the City does not have the unconditional right to defer settlement beyond 12 months, the liability is recognised as a current liability.

PROVISIONS

Provisions are recognised when: The council has a present legal or constructive obligation as a result of past events; it is more likely than not that an outflow of resources will be required to settle the obligation; and the amount has been reliably estimated. Provisions are not recognised for future operating losses. Where there are a number of similar obligations, the likelihood that an outflow will be required in settlement is determined by considering the class of obligations as a whole. A provision is recognised even if the likelihood of an outflow with respect to any one of item included in the same class of obligations may be small.

INVENTORIES

Inventories are measured at the lower of cost and net realisable value. Net realisable value is the estimated selling price in the ordinary course of business less the estimated costs of completion and the estimated costs necessary to make the sale.

NOTES TO THE STATEMENT OF FINANCIAL ACTIVITY
FOR THE PERIOD ENDED FOR THE PERIOD ENDED 30 NOVEMBER 2018

OPERATING ACTIVITIES
ADJUSTED NET CURRENT ASSETS

	Previous Period Actual	Year to Date Actual
	31 Oct 2018	30 Nov 2018
Adjusted Net Current Assets	\$	\$
Current Assets		
Cash Unrestricted	6,214,771	5,845,397
Cash Restricted (Reserves)	3,964,624	3,964,624
Receivables - Rates and Rubbish, ESL, Excess Rates	1,672,908	1,387,625
Receivables - Other	11,422	48,587
Inventories	27,142	51,727
	11,890,868	11,297,961
Less: Current Liabilities		
Payables	(613,447)	(395,666)
Loan Liability	(113,852)	(113,852)
Provisions	(596,311)	(596,311)
	(1,323,610)	(1,105,829)
Net Current Asset Position	10,567,258	10,192,132
Less: Cash Restricted	(3,964,624)	(3,964,624)
Add Back: Component of Leave Liability not Required to be funded	388,539	388,539
Add Back: Current Loan Liability	113,852	113,852
Adjustment for Trust Transactions Within Muni	(6,485)	(1,294)
Net Current Funding Position	7,098,540	6,728,605

SIGNIFICANT ACCOUNTING POLICIES

Please see page 4 for information on significant accounting policies relating to Net Current Assets.

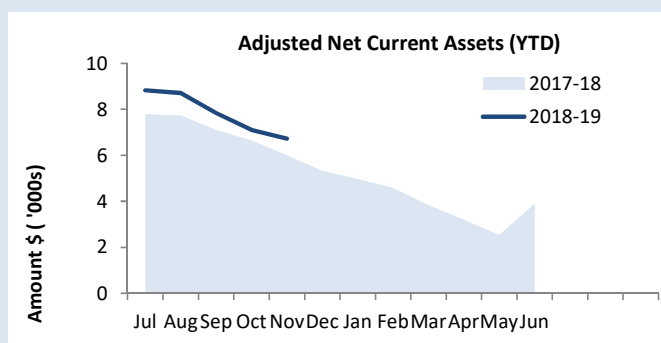

KEY INFORMATION

The amount of the adjusted net current assets at the end of the period represents the actual surplus (or deficit if the figure is a negative) as presented on the Rate Setting Statement.

Year YTD Actual

Surplus(Deficit)

\$6.73 M

Last Period Actual

Surplus(Deficit)

\$7.1 M

NOTE: For the Cash Assets above the following investments have been made as at reporting date:

<u>Cash Unrestricted</u>	<u>Investment Value \$</u>	<u>Maturity Date</u>	<u>Rate</u>	<u>Institution</u>	<u>Investment %</u>
Municipal Fund	2.0 million	27/03/2019	2.70%	NAB	50%
Municipal Fund	2.0 million	23/12/2018	2.67%	Westpac	50%
	4.0 million				100%
<u>Cash Restricted (Reserves)</u>					
Reserve Fund	1.8 million	27/06/2019	2.71%	NAB	50%
Reserve Fund	1.8 million	23/06/2019	2.71%	Westpac	50%
	3.6 million				100%
<u>Total Investment Holdings via Entity</u>					
NAB	3.8 million				50%
Westpac	1.8 million				50%
	7.6 million				100%

NOTES TO THE STATEMENT OF FINANCIAL ACTIVITY
FOR THE PERIOD ENDED FOR THE PERIOD ENDED 30 NOVEMBER 2018

EXPLANATION OF
MATERIAL VARIANCES

The material variance thresholds are adopted annually by Council as an indicator of whether the actual expenditure or revenue varies from The material variance adopted by Council for the 2018/19 year is an Actual Variance exceeding 10% and a value greater than \$15,000.

Reporting Program	Var. \$	Var. %	Var.	Timing/ Permanent	Explanation of Variance
	\$	%			
Revenue from operating activities					
Recreation and Culture	60,461	66%	▲	Permanent	Insurance claims income received for Town Hall and Public Artwork Grant revenue received for Every Club funding
Transport	64,107	33%	▲	Permanent	Direct Road Grant received higher than anticipated
Other Property and Services	19,554	33%	▲	Permanent	LGIS good claims rebate
Expenditure from operating activities					
Education and Welfare	139,084	22%	▲	Timing	HACC, CHSP, HCP & Aged Other - Expenditure estimated evenly over 12 months
Community Amenities	54,564	9%		Timing	Household waste disposal, WWT, Town Planning, Cemetery - Expenditure estimated evenly over 12 months
Recreation and Culture	(234,271)	(15%)	▼	Permanent	Other Recreation & Sport - Depreciation expenses higher than budget due to revaluation in June 2018 Other Culture - Insurance expenditure for artwork. Corresponds to revenue received P&G - budget under spent for November Town Oval - budget under spent for November
Transport	(361,344)	(14%)	▼	Permanent	Depreciation expenses higher than budget due to revaluation in June 2018
Investing Activities					
Capital Acquisitions	565,088	192%	▲	Timing	Refer to Capital Acquisitions Note
Financing Activities					

KEY INFORMATION

**NOTES TO THE STATEMENT OF FINANCIAL ACTIVITY
FOR THE PERIOD ENDED FOR THE PERIOD ENDED 30 NOVEMBER 2018**

**OPERATING ACTIVITIES
RECEIVABLES**

Rates Receivable	30 Jun 18	30 Nov 18
	\$	\$
Opening Arrears Previous Years	492,340	492,340
Levied this year		4,780,237
Movement in Excess Rates		(90,732)
Domestic Refuse Collection Charges		470,984
Domestic Services (Additional)		3,390
Commercial Collection Charge		44,583
Commercial Collection Charge (Additional)		45,287
Total Rates and Rubbish (YTD)	5,153,240	5,263,049
Less Collections to date	(5,153,240)	(4,207,447)
Net Rates Collectable	492,340	1,547,943
% Collected	91.28%	73.22%
Pensioner Deferred Rates		(153,532)
Pensioner Deferred ESL		(6,786)
Total Rates and Rubbish, ESL, Excess Rates		1,387,625

Receivables - General	Current	30 Days	60 Days	90+ Days	Total
	\$	\$	\$	\$	\$
Receivables - General	19,525	4,084	632	12,659	36,900
Percentage	53%	11%	2%	34%	
Balance per Trial Balance					
Rates Pensioner Rebate Claims					2,435
GST Input					46,220
Provision For Doubtful Debts					(37,776)
Total Receivables General Outstanding					47,779
Amounts shown above include GST (where applicable)					

KEY INFORMATION

Trade and other receivables include amounts due from ratepayers for unpaid rates and service charges and other amounts due from third parties for goods sold and services performed in the ordinary course of business.

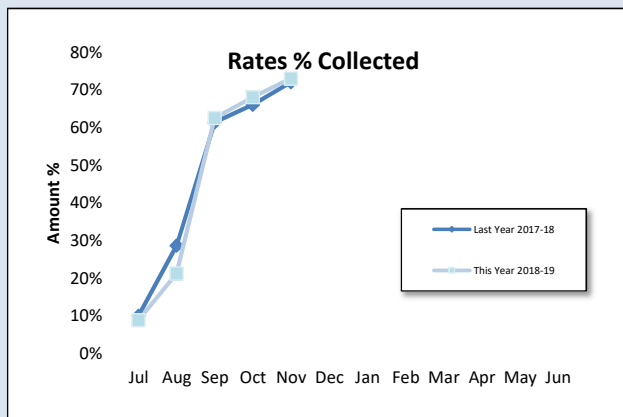

Collected	Rates Due
73%	\$1,387,625

SIGNIFICANT ACCOUNTING POLICIES

Trade and other receivables include amounts due from ratepayers for unpaid rates and service charges and other amounts due from third parties for goods sold and services performed in the ordinary course of business. Receivables expected to be collected within 12 months of the end of the reporting period are classified as current assets. All other receivables are classified as non-current assets. Collectability of trade and other receivables is reviewed on an ongoing basis. Debts that are known to be uncollectible are written off when identified. An allowance for doubtful debts is raised when there is objective evidence that they will not be collectible.

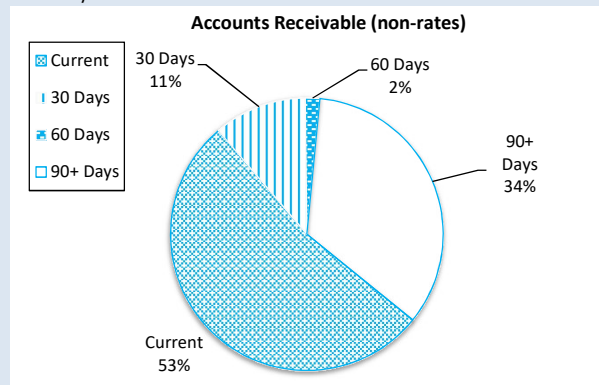

Debtors Due
\$47,779
Over 30 Days
47%
Over 90 Days
34%

**NOTES TO THE STATEMENT OF FINANCIAL ACTIVITY
FOR THE PERIOD ENDED FOR THE PERIOD ENDED 30 NOVEMBER 2018**

**INVESTING ACTIVITIES
CAPITAL ACQUISITIONS**

Capital Acquisitions	Annual Budget	Revised Budget	YTD Budget	YTD Actual Total	YTD Budget Variance
	\$	\$	\$	\$	\$
Land and Buildings	1,325,039	1,520,798	141,331	99,523	41,808
Plant & Equipment	1,413,335	1,413,335	864,030	521,665	342,365
Furniture & Equipment	71,210	71,210	52,210	35,091	17,119
Roads	1,632,644	1,632,644	408,140	223,338	184,802
Footpaths	69,000	69,000	0	28,100	(28,100)
Road Drainage	33,589	33,589	1,598	1,100	498
Other Infrastructure	644,114	644,114	88,440	81,844	6,596
Capital Expenditure Totals	5,188,930	5,384,689	1,555,749	990,661	565,088

SIGNIFICANT ACCOUNTING POLICIES

All assets are initially recognised at cost. Cost is determined as the fair value of the assets given as consideration plus costs incidental to the acquisition. For assets acquired at no cost or for nominal consideration, cost is determined as fair value at the date of acquisition. The cost of non-current assets constructed by the local government includes the cost of all materials used in the construction, direct labour on the project and an appropriate proportion of variable and fixed overhead. Certain asset classes may be revalued on a regular basis such that the carrying values are not materially different from fair value. Assets carried at fair value are to be revalued with sufficient regularity to ensure the carrying amount does not differ materially from that determined using fair value at reporting date.

KEY INFORMATION

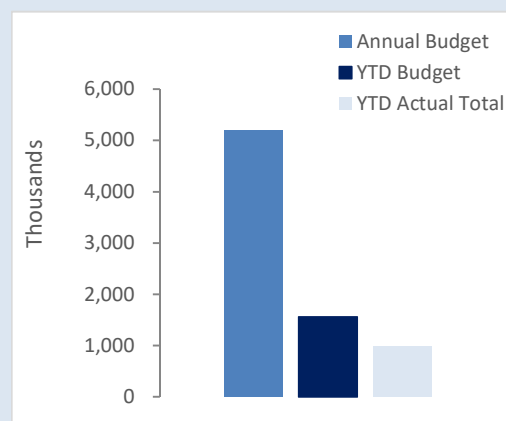

Acquisitions	Annual Budget	YTD Actual	% Spent
	\$5.19 M	\$.99 M	18%





















































To be read in conjunction with Strategic Projects Tracker

* Budget profiles were not loaded by completion of this report. YTD Budget totals are still to be finalised for Capital *

**NOTES TO THE STATEMENT OF FINANCIAL ACTIVITY
FOR THE PERIOD ENDED FOR THE PERIOD ENDED 30 NOVEMBER 2018**

**INVESTING ACTIVITIES
CAPITAL ACQUISITIONS (CONTINUED)**













































% of Completion

	Original Budget	YTD Budget	YTD Actual	Variance Under(Over)
	\$	\$	\$	\$
Capital Expenditure				
Land and Buildings				
 Building Renovation Administration	190,060	0	3,700	(3,700)
 Animal Pound Building (Capital)	7,781	7,781	0	7,781
 Other Law & Order Building (Capital)	455	454	455	(1)
 HACC - Building (Capital)	50,500	0	0	0
 Mackie Park Public Toilets and Office - Capital	15,000	15,000	0	15,000
 Memorial Park Public Toilets Capital	100,000	100,000	0	100,000
 Highbury Public Toilets (Capital)	10,000	0	5,525	(5,525)
 Town Hall (Federal St) Building Capital	75,760	0	0	0
 Railway Institute Hall & Office Building Capital	3,096	3,096	0	3,096
 Highbury Hall Building Capital	15,000	15,000	5,937	9,063
 NRRC Building (Capital)	123,600	0	80,961	(80,961)
 NRRC Building Capital 2018-19	64,259	0	545	(545)
 Library Landscape - Stage 1	100,000	0	0	0
 Railway Station Building (Capital)	6,641	0	0	0
 Museum Building (Capital)	5,000	0	0	0
 Accommodation Units (NCP)	351,364	0	1,800	(1,800)
 Caravan Park Renovations	183,896	0	600	(600)
 Visitor Information Bay Upgrade (Williams Road)	20,000	0	0	0
 Sale Yard (Showmen's) Toilets Building Capital	2,627	0	0	0
	1,325,039	141,331	99,523	41,808
Plant and Equipment				
 Fire Truck (Highbury)	50,000	0	0	0
 NO05 Ranger Vehicle 2018	42,606	42,606	36,790	5,816
 EHO Vehicle 2018	21,000	21,000	18,602	2,398
 NGN10179 Toyota Hiace 2018	58,000	58,000	0	58,000
 Lawn Mower 2018	2,000	2,000	1,590	410
 Brush Cutter 2018	1,000	1,000	0	1,000
 NGN839 CHCP Vehicle	27,000	0	0	0
 NGN219 CATS Vehicle 2019	26,500	0	0	0
 CCTV Installation Refuse Site	10,000	10,000	0	10,000
 NGN00 EMDRS Vehicle 2018(2)	35,755	35,755	35,134	621
 NGN00 EMDRS Vehicle 2019	35,755	0	0	0
 NGN00 EMDRS Vehicle 2019(2)	35,755	0	0	0
 CCTV Installation Old Courthouse Museum	7,500	0	0	0
 ONO EMTRS Vehicle 2018 (3)	36,508	36,508	36,389	119
 ONO EMTRS Vehicle 2019	36,508	0	0	0
 ONO EMTRS Vehicle 2019 (2)	36,508	0	0	0
 ONO EMTRS Vehicle 2019 (3)	36,508	0	0	0
 N001 MO Vehicle 2018(2)	36,870	36,870	36,243	627
 N001 MO Vehicle 2019	36,870	0	0	0
 N001 MO Vehicle 2019(2)	36,870	0	0	0
 Works Supervisor Vehicle 2018	43,000	43,000	35,416	7,584
 1N0 CF Vehicle 2018	43,000	43,000	36,498	6,502
 NGN802 Gardener Vehicle 2018	28,000	28,000	23,677	4,323
 NO1 2018 UD 6 Wheeler Nissan Diesel Tip Truck	226,000	226,000	0	226,000
 NO592 PG LH Vehicle PG 2018	32,000	32,000	27,368	4,632
 NGN677 Toro Mower 2018 (WORKS) (PE041)	35,000	35,000	33,000	2,000
 NO2731 Four Axle Side Tipping Trailer - Additions	25,000	0	0	0
 NO2706 Four Axle Side Tipping Trailer - Additions	25,000	0	0	0
 Workshop Tool Purchase (Mechanic)	15,000	15,000	14,206	794
 New VHF Radios x 15	15,000	15,000	0	15,000
 NGN6121 1982 Twin Drum Turf Roller (WORKS)	35,000	35,000	34,850	150
 CCTV Installation NCP	10,000	10,000	8,500	1,500
 1NGN CEO Vehicle 2018(2)	53,040	53,040	51,593	1,447
 1NGN CEO Vehicle 2019	49,440	0	48,438	(48,438)

**NOTES TO THE STATEMENT OF FINANCIAL ACTIVITY
FOR THE PERIOD ENDED FOR THE PERIOD ENDED 30 NOVEMBER 2018**

**INVESTING ACTIVITIES
CAPITAL ACQUISITIONS (CONTINUED)**



















% of Completion

	Original Budget	YTD Budget	YTD Actual	Variance Under(Over)	
 1NGN CEO Vehicle 2019(2)	49,440	0	0	0	
 ONGN EMCCS Vehicle 2018(2)	35,251	35,251	0	35,251	
 ONGN EMCCS Vehicle 2019	34,651	0	0	0	
 002 NGN MF Vehicle 2018	25,000	25,000	21,804	3,196	
 NGN 0 MLC Vehicle 2018	25,000	25,000	21,568	3,432	
	1,413,335	864,030	521,665	342,365	
Furniture and Equipment					
 Airconditioner Upgrade - DRS	20,000	20,000	0	20,000	
 Replace Pelments and Drapes, Jessie House	4,000	0	0	0	
 Mobile Works Solution (HACC)	20,000	20,000	28,211	(8,211)	
 Town Hall Airconditioner	15,000	0	0	0	
 Jessie House Airconditioner	0	0	6,881	(6,881)	
 Library Software Upgrade	12,210	12,210	0	12,210	
	71,210	52,210	35,091	17,119	
Infrastructure - Roads					
 Earl Street - Renewal (Local)	49,813	12,452	0	12,452	
 Egerton Street - Upgrade (Local)	171,494	42,871	34,049	8,822	
 Whinbin Rock Road - Renewal (Rural)	70,618	17,652	0	17,652	
 Wagin-Wickepin Road - Renewal (Local)	99,625	24,905	0	24,905	
 Wangeling Gully Road - Renewal (Rural)	90,792	22,697	0	22,697	
 Quarry Road - Renewal (Rural)	85,627	21,405	0	21,405	
 Gordon Street - Renewal (Local) (R2R)	9,300	2,325	0	2,325	
 Earl Street North - Renewal (Local) (R2R)	25,800	6,450	0	6,450	
 Floreat Street - Renewal (Local) (R2R)	14,640	3,660	0	3,660	
 Hough Street - Renewal (Local) (R2R)	16,815	4,203	0	4,203	
 Park Street - Renewal (Local) (R2R)	11,655	2,913	0	2,913	
 Northwood Street - Renewal (Local) (R2R)	12,240	3,060	0	3,060	
 Palmer Street - Renewal (Local) (R2R)	7,875	1,968	0	1,968	
 Watt Street - Renewal (Local) (R2R)	6,900	1,725	0	1,725	
 Short Street - Renewal (Local) (R2R)	2,850	712	0	712	
 Horace Street - Renewal (Local) (R2R)		8,910	2,227	0	2,227
 Harper Street - Renewal (Local) (R2R)		10,260	2,565	0	2,565
 Falcon Street - Renewal (Local) (R2R)		12,000	3,000	0	3,000
 Argus Street - Renewal (Local) (R2R)		4,050	1,012	0	1,012
 Quigley Street Short Street - Renewal (Local) (R2R)		8,880	2,220	0	2,220
 Narrakine Road South - Renewal (Rural) (R2R)		123,027	30,755	37,531	(6,776)
 Herald Street - Upgrade (Local) (RRG)		637,565	159,388	70,218	89,170
 Congelin - Narrogin Road - Renewal (Local) (RRG)		151,908	37,975	81,540	(43,565)
	1,632,644	408,140	223,338	184,802	
Infrastructure - Footpaths					
 Mackie Park - Footpath Construction	10,000	0	0	0	
 Earl St Footpath Construction	9,000	0	5,300	(5,300)	
 Doney Street Footpath Construction	50,000	0	22,800	(22,800)	
	69,000	0	28,100	(28,100)	
Infrastructure - Drainage					
 Drainage - Butler Street	33,589	1,598	1,100	498	
	33,589	1,598	1,100	498	
Infrastructure - Other					
 Refuse Site Transfer Station	10,000	5,000	8,364	(3,364)	
 Bin Surrounds	21,600	0	20,262	(20,262)	
 Cemetery Upgrade	57,440	57,440	0	57,440	
 Gnarojin Park Master Plan	23,248	0	21,745	(21,745)	
 CBD Design - Colour Palette and signage	10,000	0	0	0	
 Townscape - Highbury	5,000	0	2,260	(2,260)	
 Townscape - Narrogin	10,000	0	0	0	

**NOTES TO THE STATEMENT OF FINANCIAL ACTIVITY
FOR THE PERIOD ENDED FOR THE PERIOD ENDED 30 NOVEMBER 2018**

**INVESTING ACTIVITIES
CAPITAL ACQUISITIONS (CONTINUED)**

% of Completion

	Original Budget	YTD Budget	YTD Actual	Variance Under(Over)
 NRRC Infrastructure Other (Capital)	10,000	10,000	(60)	10,060
 Foxes Lair	17,000	0	0	0
 Heritage Trail	28,015	0	0	0
 McKenzie Park - Playground Equipment	10,000	0	0	0
 Pine Park - Playground Equipment	12,000	6,000	1,810	4,190
 Ashworth Park - Playground Equipment	20,000	10,000	0	10,000
 Highbury Tennis Court	75,000	0	0	0
 Narrogin Walk Trails Master Plan	16,000	0	7,950	(7,950)
 Mountain Bike & Pump Track Feasibility Study	9,000	0	0	0
 Skate Park Improvements	69,811	0	16,552	(16,552)
 Gnarojin Community Garden Carpark & Driveway Upgrade	10,000	0	0	0
 Museum Carpark	60,000	0	0	0
 Pioneer Drive Carpark	50,000	0	0	0
 Aerodrome Infrastructure Other (Capital)	30,000	0	144	(144)
 Caravan Park Resealing, Line Marking	20,000	0	0	0
 Local Tourism Planning Strategy	20,000	0	0	0
 Site Inspection Report - Felspar St Depot	20,000	0	2,817	(2,817)
 Economic Development Strategy	30,000	0	0	0
	644,114	88,440	81,844	6,596

Capital Expenditure Total

Level of Completion Indicators

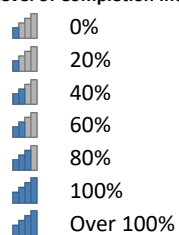

Percentage YTD Actual to Annual Budget
Expenditure over budget highlighted in red.

Variance is calculated on:
YTD Budget vs YTD Actual

**NOTES TO THE STATEMENT OF FINANCIAL ACTIVITY
FOR THE PERIOD ENDED FOR THE PERIOD ENDED 30 NOVEMBER 2018**

**OPERATING ACTIVITIES
CASH AND INVESTMENTS**

Cash Backed Reserve

Reserve Name	Opening Balance	Current Budget Interest Earned	Actual Interest Earned	Current Budget Transfers In (+)	Actual Transfers In (+)	Current Budget Transfers Out (-)	Actual Transfers Out (-)	Current Budget Closing Balance	Actual YTD Closing Balance
	\$	\$	\$	\$	\$	\$	\$	\$	\$
Refuse	376,475	6,827	935	50,000	0	0	0	433,302	377,410
CAT Vehicle Replacement	4,297	78	10	7,125	0	11,500	0	0	4,307
Building	686,182	12,444	1,705	80,000	0	280,000	0	498,626	687,887
NRRC	214,761	3,895	534	140,000	0	90,000	0	268,656	215,295
Employee Entitlement	387,576	7,029	963	0	0	0	0	394,605	388,539
Plant, Vehicle & Equipment	333,984	6,057	830	425,000	0	442,500	0	322,541	334,814
Unspent Grants and Contributions	44,816	811	113	0	0	4,724	0	40,903	44,929
Economic Development	152,014	2,757	377	18,552	0	0	0	173,323	152,391
IT & Office Equipment	66,049	1,198	164	5,000	0	0	0	72,247	66,213
Tourism & Area Promotion	75,469	1,369	188	0	0	0	0	76,838	75,657
HACC	784,351	14,224	1,948	0	0	139,916	0	658,659	786,299
CHCP	241,070	4,372	599	0	0	53,213	0	192,229	241,669
Road Construction	301,328	5,465	749	42,332	0	0	0	349,125	302,077
Asset Valuation	30,610	555	76	0	0	0	0	31,165	30,686
CHSP	160,970	2,919	399	0	0	11,514	0	152,375	161,369
Landcare	94,846	0	236	0	0	0	0	94,846	95,082
	3,954,799	70,000	9,826	768,009	0	1,033,367	0	3,759,441	3,964,624

KEY INFORMATION

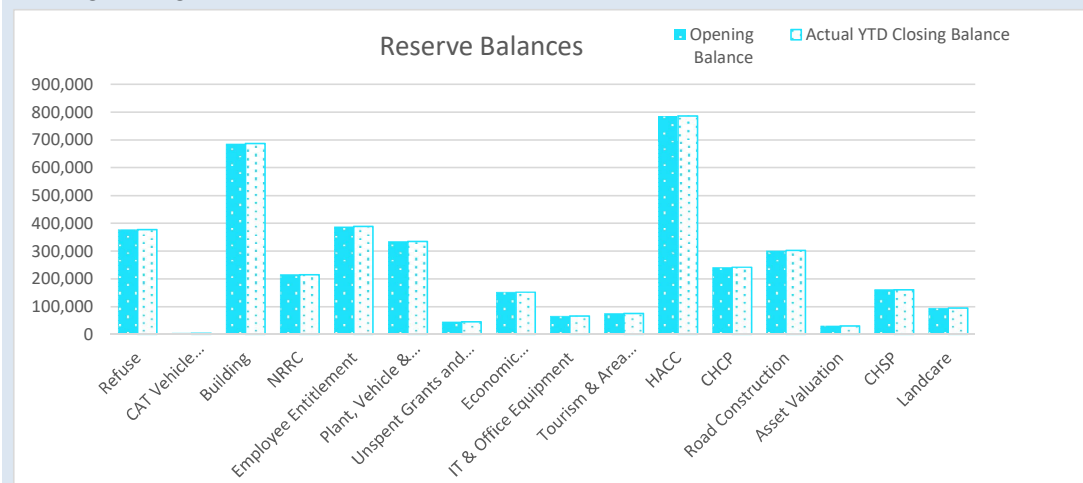

**Shire of Narrogin
Strategic Projects 2018/19**

For the Period Ended 30 November 2018

Project Progress	
Complete	
On Track	
Off Track	
In Trouble	

Line No	COA Description	Project Type	Project Title	Project Description	2018/19 Annual Budget	2018/19 YTD Actual	Responsible Officer	Project Progress	2018						Comments
									July	August	September	October	November	December	
Governance															
1	OTHGOV - Capital Furniture & Equipment		Airconditioner Upgrade - DRS	New air conditioner for the DRS area	20,000.00	-	Azhar Awang								
2	OTHGOV - Capital Administration Building		Building Renovation Administration	Toilets \$30,000, reception \$50,000, Covered Entry \$100,000	190,060.00	3,700.00	Azhar Awang								
Law, Order & Public Safety															
3	FIRE - Plant & Equipment (Capital)	Cr	Fire Truck (Highbury)	Purchase 2nd hand fire truck to be placed in Highbury	50,000.00	-	Azhar Awang								
4	ANIMAL - Building (Capital)		Animal Pound Capital	Noise control upgrade	7,781.00	-	Azhar Awang								
5	ANIMAL - Plant & Equipment (Capital)		NO05 Ranger Vehicle 2018		42,606.00	36,789.68	Azhar Awang								
6	SAN - Infrastructure Other (Capital) GEN	C/FWD	CCTV Installation Refuse Site		10,000.00	-	Azhar Awang								
Education & Welfare															
7	HEALTH - Plant & Equipment (Capital)		EHO Vehicle 2018	New Senior EHO Vehicle	21,000.00	18,602.18	Azhar Awang								
8	HACC - Furniture & Equipment (Capital)		Replace Pelments and Drapes, Jessie House	Replace pelments and drapes at Jessie House	4,000.00	-	Frank Ludovico								
9	HACC - Plant & Equipment (Capital)		Lawn Mower 2018	Lawn Mower	2,000.00	1,590.00	Frank Ludovico								
10	HACC - Plant & Equipment (Capital)		Brush Cutter 2018	Brush Cutter	1,000.00	-	Frank Ludovico								
11	HACC - Building (Capital)		HACC - Building (Capital)	Install Electric sliding doors at Jessie House \$13,000.	13,000.00	-	Frank Ludovico								
12	HACC - Building (Capital)		HACC - Building (Capital)	Supply & install bathroom vinyl floor covering \$2,500, Floor covering activity area \$23,000, Repainting of Jessie House \$12,000	50,500.00	-	Frank Ludovico								
13	HACC - Plant & Equipment (Capital) GEN	C/FWD	HACC - Plant & Equipment (Capital) GEN	Replacement HiAce Bus	58,000.00	-	Frank Ludovico								
14	CHCP - Furniture & Equipment (Capital)	C/FWD	Mobile Works Solution (HACC)	Alchemy Technology Interface and IT purchase of Mobile Works solution	20,000.00	28,210.76	Frank Ludovico								
15	CHCP - Plant & Equipment (Capital) GEN		NGN 839 Toyota Altise		27,000.00	-	Frank Ludovico								
16	AGEDOTHER - Plant & Equipment (Capital)		NGN219 CATS Vehicle 2019		26,500.00	-	Frank Ludovico								
Community Amenities															
17	SAN - Infrastructure Other (Capital)		Refuse Site Transfer Station	Installation of Safety railing at transfer station (OHS Audit Report)	10,000.00	8,363.64	Azhar Awang								
18	SAN - Infrastructure Other (Capital)	C/FWD	Installation on Bin Surrounds	Installation of Bin Surrounds - Townscape	21,600.00	20,262.13	Azhar Awang								
19	PLAN - Plant & Equipment		NGN00 EMDRS Vehicle 2018(2)		35,755.00	35,134.27	Torre Evans								
20	PLAN - Plant & Equipment		NGN00 EMDRS Vehicle 2019		35,755.00	-	Torre Evans								
21	PLAN - Plant & Equipment		NGN00 EMDRS Vehicle 2019(2)		35,755.00	-	Torre Evans								
22	COM AMEN - Building (Capital) - Other Community Amenities		Mackie Park Public Toilets and Office (Capital)	Refurb baby changeroom \$15,000.	15,000.00	-	Azhar Awang								
23	COM AMEN - Building (Capital) - Other Community Amenities	2017/18	Memorial Park Public Toilets Capital	Design, planning & demolition. Construction new Public Toilet	100,000.00	-	Azhar Awang								
24	COM AMEN - Building (Capital) - Other Community Amenities		Highbury Public Toilets (Capital)	Retaining wall and infill around new leach drains installed	10,000.00	5,525.00	Azhar Awang								
25	COM AMEN - Infrastructure Other (Capital) - Other Community Amenities	C/FWD	Cemetery Upgrade	C/F: Design, survey, stormwater & road design for extension of the cemetery \$57,440.	57,440.00	-	Azhar Awang								
26	COM AMEN - Infrastructure Other (Capital) - Other Community Amenities	C/FWD	Gnarojin Park Master Plan	Completion of Plan	23,247.73	21,745.00	Azhar Awang								
27	COM AMEN - Infrastructure Other (Capital) - Other Community Amenities		Townscape - Highbury	Highbury Townscape annual allocation	5,000.00	2,260.00	Azhar Awang								
28	COM AMEN - Infrastructure Other (Capital) - Other Community Amenities		Townscape - Narrogin	Narrogin Townscape annual allocation	10,000.00	-	Azhar Awang								
Recreation & Culture															
29	HALLS - Furniture & Equipment (Capital) GEN	Comm	Town Hall Airconditioner	Humidifier and air cond of Art Collection	7,500.00	-	Azhar Awang								
30	HALLS - Furniture & Equipment (Capital) GEN		Town Hall Airconditioner	Relocate Air conditioner	7,500.00	-	Azhar Awang								
31	HALLS - Building (Capital)	C/FWD	Town Hall (Federal St) Building Capital	Repitching of Mayors parlour roof.	75,760.00	-	Azhar Awang								
32	HALLS - Building (Capital)	CBP	Railway Institute Hall & Office Building Capital	As per Corporate Business Plan replace 72m timber roof fascia \$3,096	3,096.00	-	Azhar Awang								
33	HALLS - Building (Capital)	CBP	Highbury Hall Building Capital	Rewire Highbury Hall \$10,000	15,000.00	5,937.00	Azhar Awang								
34	NRRC - Building (Capital)		NRRC Building (Capital)	Exhaust system upgrade \$40,000, Re-tile dry side changerooms \$20,000, Boiler repairs \$30,000	123,600.00	80,961.20	Azhar Awang								
35	NRRC - Building (Capital)	CBP	NRRC Building Capital 2018-19	Replace 624.9m2 metal roofing \$44,368, replace 375.3m2 gyprock lined ceiling \$19,891.	64,259.00	545.46	Azhar Awang								
36	NRRC - Infrastructure Other (Capital)	C/FWD	NRRC Infrastructure Other (Capital)	Multiple Club trophy cabinet \$10,000	10,000.00	60.00	Azhar Awang								

Line No	COA Description	Project Type	Project Title	Project Description	2018/19 Annual Budget	2018/19 YTD Actual	Responsible Officer		July	August	September	October	November	December	Comments
37	REC - Infrastructure Other (Capital)		Foxes Lair	Repair washouts to Foxes Lair tracks \$10,000, Signage \$7,000	17,000.00	-	Azhar Awang	●							
38	REC - Infrastructure Other (Capital)	Cr	Highbury Tennis Court	Resurface Highbury Tennis Court (Shire contribution of 30%)	75,000.00	-	Azhar Awang	●							
39	REC - Infrastructure Other (Capital)		Skate Park Improvements	Landscaping, shades and furniture \$10,000 C/F: \$18,080 (MRWA already received) Skate park urban art project, Shade sails \$20,000, skate park bins and surrounds \$3,000, seating \$12,000	69,810.91	16,551.84	Azhar Awang	●							
40	REC - Infrastructure Other (Capital)	C/FWD	Heritage Trail	Heritage Plaques Production Stage 2 - 10 additional plaques \$12,000, QR code development & production \$2,000, Plaque installation \$3500.	28,015.00	-	Azhar Awang	●							
41	REC - Infrastructure Other (Capital)		McKenzie Park - Playground Equipment	Shade shelter, table & seating \$10,000,	10,000.00	-	Azhar Awang	●							
42	REC - Infrastructure Other (Capital)	2017/18	Pine Park - Playground Equipment	Basketball half court \$12,000 Councillor request	12,000.00	1,810.00	Torre Evans	●							
43	REC - Infrastructure Other (Capital)	2017/18	Ashworth Park - Playground Equipment	Ashworth Park Shade Structure	20,000.00	-	Torre Evans	●							
44	REC - Infrastructure Other (Capital)		Narrogin Walk Trails Master Plan	Narrogin Walk Trails Master plan	16,000.00	7,950.00	Azhar Awang	●							
45	REC - Infrastructure Other (Capital)		Mountain Bike & Pump Track Feasibility Study	Mountain bike & pump track feasibility study	9,000.00	-	Azhar Awang	●							Pending financial input from Keedac
46	LIB - Furniture and Equipment	C/FWD	Library Software Upgrade	Completion of software installation	12,210.00	-	Frank Ludovico	●							
47	LIB - Building (Capital)	C/FWD	Library Landscape - Stage 1A	Library Landscape - Stage 1	100,000.00	-	Frank Ludovico/Keenan	●							
48	HERITAGE - Building (Capital)	CBP	Museum Building (Capital)	Install disability access at the Old Courthouse Museum \$5,000.	5,000.00	-	Azhar Awang	●							
49	HERITAGE - Building (Capital)		CCTV Installation Old Courthouse Museum	Install CCTV Old Courthouse Museum \$7,500.	7,500.00	-	Azhar Awang	●							
50	OTHCUL - Gnarojin Community Garden Carpark & Driveway Upgrade		Gnarojin Community Garden Carpark & Driveway Upgrade	Upgrade carpark with blue metal to make more durable during winter, upgrade driveway and rear access with blue metal	10,000.00	-	Azhar Awang	●							
51	COM AMEN - Infrastructure Other (Capital) - Other Community Amenities		CBD Design - Colour Palette and signage	CBD Design - Colour palette and signage recommendations Part of \$20,000 Townscape annual allocation	10,000.00	-	Azhar Awang	●							
52	ROADC - Infrastructure Other (Capital)		Museum Carpark	Renew with asphalt and kerbing (many cracked and lifted areas)	60,000.00	-	Torre Evans	●							
53	ROADC - Infrastructure Other (Capital)		Pioneer Carpark	Preliminary Carpark Earthworks (Cr request)	50,000.00	-	Torre Evans	●							
54	ROADC - Roads (Capital) - Council Funded		Earl Street - Renewal (Local)	Stabilising and seal	49,813.00	-	Torre Evans	●							
55	ROADC - Roads (Capital) - Council Funded		Egerton Street - Upgrade (Local)	Reconstruction	171,494.00	34,048.85	Torre Evans	●							
56	ROADC - Roads (Capital) - Council Funded		Whinbin Rock Road - Renewal (Rural)	Resheet	70,618.00	-	Torre Evans	●							
57	ROADC - Roads (Capital) - Council Funded		Wagin-Wickepin Road - Renewal (Local)	Reconstruct Stabilise and seal	99,625.00	-	Torre Evans	●							
58	ROADC - Roads (Capital) - Council Funded		Wangeling Gully Road - Renewal (Rural)	Resheet	90,792.00	-	Torre Evans	●							
59	ROADC - Roads (Capital) - Council Funded		Quarry Road - Renewal (Rural)	Resheet	85,627.00	-	Torre Evans	●							
60	ROADC - Roads (Capital) - Roads to Recovery		Gordon Street - Renewal (Local) (R2R)	Reseal	9,300.00	-	Torre Evans	●							
61	ROADC - Roads (Capital) - Roads to Recovery		Earl Street North - Renewal (Local) (R2R)	Reseal	25,800.00	-	Torre Evans	●							
62	ROADC - Roads (Capital) - Roads to Recovery		Floreat Street - Renewal (Local) (R2R)	Reseal	14,640.00	-	Torre Evans	●							
63	ROADC - Roads (Capital) - Roads to Recovery		Hough Street - Renewal (Local) (R2R)	Reseal	16,815.00	-	Torre Evans	●							
64	ROADC - Roads (Capital) - Roads to Recovery		Park Street - Renewal (Local) (R2R)	Reseal	11,655.00	-	Torre Evans	●							
65	ROADC - Roads (Capital) - Roads to Recovery		Northwood Street - Renewal (Local) (R2R)	Reseal	12,240.00	-	Torre Evans	●							
66	ROADC - Roads (Capital) - Roads to Recovery		Palmer Street - Renewal (Local) (R2R)	Reseal	7,875.00	-	Torre Evans	●							
67	ROADC - Roads (Capital) - Roads to Recovery		Watt Street - Renewal (Local) (R2R)	Reseal	6,900.00	-	Torre Evans	●							
68	ROADC - Roads (Capital) - Roads to Recovery		Short Street - Renewal (Local) (R2R)	Reseal	2,850.00	-	Torre Evans	●							
69	ROADC - Roads (Capital) - Roads to Recovery		Horace Street - Renewal (Local) (R2R)	Reseal	8,910.00	-	Torre Evans	●							
70	ROADC - Roads (Capital) - Roads to Recovery		Harper Street - Renewal (Local) (R2R)	Reseal	10,260.00	-	Torre Evans	●							
71	ROADC - Roads (Capital) - Roads to Recovery		Falcon Street - Renewal (Local) (R2R)	Reseal	12,000.00	-	Torre Evans	●							
72	ROADC - Roads (Capital) - Roads to Recovery		Argus Street - Renewal (Local) (R2R)	Reseal	4,050.00	-	Torre Evans	●							
73	ROADC - Roads (Capital) - Roads to Recovery		Quigley Street Short Street - Renewal (Local) (R2R)	Reseal	8,880.00	-	Torre Evans	●							
74	ROADC - Roads (Capital) - Roads to Recovery		Narrakine Road South - Renewal (Rural) (R2R)	Reconstruction and Seal	123,027.00	37,531.02	Torre Evans	●							
75	ROADC - Roads (Capital) - Regional Road Group		Herald Street - Upgrade (Local) (RRG)	Reconstruction	637,565.00	70,217.67	Torre Evans	●							
76	ROADC - Roads (Capital) - Regional Road Group		Congelin - Narrogin Road - Renewal (Local) (RRG)	Stabilise and Seal	151,908.00	81,540.35	Torre Evans	●							
77	ROADC - Footpaths (Capital)		Mackie Park - Footpath Construction	Replace broken, cracked concrete footpath with new	10,000.00	-	Torre Evans	●							
78	ROADC - Footpaths (Capital)		Earl St Footpath Construction	To improve safety of footpath in front of ABC Kindergarten	9,000.00	5,300.00	Torre Evans	●							
79	ROADC - Footpaths (Capital)	2017/18	Doney Street Footpath Construction	Part of 5 year footpath program Full length	50,000.00	22,800.00	Torre Evans	●							
80	ROADC - Drainage (Capital)		Drainage - Butler Street	December 2017 Council meeting Resolution 1217.141	33,589.00	1,100.00	Azhar Awang	●							
81	AERO - Infrastructure Other (Capital) - Aerodromes	CBP	Aerodrome Infrastructure Other (Capital)	Sealed apron off runway next to water tank for refilling water bombers \$10,000.	10,000.00	144.00	Torre Evans	●							
82	AERO - Infrastructure Other (Capital) - Aerodromes	CBP	Aerodrome Infrastructure Other (Capital)	As per Corporate Business Plan Airport Master Plan \$20,000 (Total of \$30,000 to be spent)	20,000.00	-	Torre Evans	●							

Line No	COA Description	Project Type	Project Title	Project Description	2018/19 Annual Budget	2018/19 YTD Actual	Responsible Officer		July	August	September	October	November	December	Comments
83	PLANT - Plant & Equipment (Capital)		ONO EMTRS Vehicle 2018 (3)		36,508.00	36,388.81	Torre Evans	●							
84	PLANT - Plant & Equipment (Capital)		ONO EMTRS Vehicle 2019		36,508.00	-	Torre Evans	●							
85	PLANT - Plant & Equipment (Capital)		ONO EMTRS Vehicle 2019 (2)		36,508.00	-	Torre Evans	●							
86	PLANT - Plant & Equipment (Capital)		ONO EMTRS Vehicle 2019 (3)		36,508.00	-	Torre Evans	●							
87	PLANT - Plant & Equipment (Capital)		N001 MO Vehicle 2018(2)		36,870.00	36,242.56	Torre Evans	●							
88	PLANT - Plant & Equipment (Capital)		N001 MO Vehicle 2019		36,870.00	-	Torre Evans	●							
89	PLANT - Plant & Equipment (Capital)		N001 MO Vehicle 2019(2)		36,870.00	-	Torre Evans	●							
90	PLANT - Plant & Equipment (Capital)		Works Supervisor Vehicle 2018		43,000.00	35,415.91	Torre Evans	●							
91	PLANT - Plant & Equipment (Capital)		1N0 CF Vehicle 2018		43,000.00	36,497.73	Torre Evans	●							
92	PLANT - Plant & Equipment (Capital)		NGN802 Gardener Vehicle 2018		28,000.00	23,677.28	Torre Evans	●							
93	PLANT - Plant & Equipment (Capital)		NO1 2018 UD 6 Wheeler Nissan Diesel Tip Truck		226,000.00	-	Torre Evans	●							
94	PLANT - Proceeds from Disposal of Asset		Proceeds on Disposal - NO2776 2013 eCombi Broons Roller		-	-	Torre Evans	●							
95	PLANT - Plant & Equipment (Capital)		NO592 PG LH Vehicle PG 2018		32,000.00	27,368.18	Torre Evans	●							
96	PLANT - Plant & Equipment (Capital)		NGN677 Toro Mower 2018 (WORKS) (PE041)		35,000.00	33,000.00	Torre Evans	●							
97	PLANT - Plant & Equipment (Capital)		NO2731 Four Axle Side Tipping Trailer - Additions	Refurbishment	25,000.00	-	Torre Evans	●							
98	PLANT - Plant & Equipment (Capital)		NO2706 Four Axle Side Tipping Trailer - Additions	Refurbishment	25,000.00	-	Torre Evans	●							
99	PLANT - Plant & Equipment (Capital)		Workshop Tool Purchase (Mechanic)		15,000.00	14,205.64	Torre Evans	●							
100	PLANT - Plant & Equipment (Capital)		New VHF Radios x 15		15,000.00	-	Torre Evans	●							
101	PLANT - Plant & Equipment (Capital)		NGN6121 1982 Twin Drum Turf Roller (WORKS)		35,000.00	34,850.00	Torre Evans	●							
Economic Services															
102	TOUR - Plant & Equipment (Capital)	C/FWD	CCTV Installation NCP		10,000.00	8,500.00	Frank Ludovico	●							
103	TOUR - Building (Capital)	C/FWD	Accommodation Units (NCP)		351,363.64	1,800.00	Frank Ludovico	●							
104	TOUR - Building (Capital)	C/FWD	Caravan Park Renovations	Retiling of ablution block 1 \$60,000, Universal access toilet \$60,000	183,896.00	600.00	Frank Ludovico	●							
105	TOUR - Building (Capital)		Visitor Information Bay Upgrade (Williams Road)	Remove old signs, repaint, install new signs	20,000.00	-	Azhar Awang	●							
106	TOUR - Infrastructure Other (Capital)	C/FWD	Caravan Park Resealing, Line Marking	Resealing of Caravan Park, Line marking	20,000.00	-	Frank Ludovico	●							
107	TOUR - Infrastructure Other (Capital)		Local Tourism Planning Strategy	The preparation of a plan exploring options for the development of tourism in the Shire	20,000.00	-	Azhar Awang	●							
108	COM AMEN - Building (Capital) Other Community Amenities	CBP	Sale Yard (Showmen's) Toilets Building Capital	As per Corporate Business Plan replace 37m2 metal roofing \$2,627	2,627.00	-	Azhar Awang	●							
109	ECONOM - Infrastructure Other (Capital)		Site Inspection Report - Felspar St Depot	Detailed Site Inspection report for contamination Felspar St Depot Part 1 of Stage 2	20,000.00	2,817.38	Azhar Awang	●							
110	ECONOM - Infrastructure Other (Capital)		Economic Development Strategy	The preparation of a plan exploring options for Economic development in the Shire	30,000.00	-	Dale Stewart	●							
Other Property & Services															
111	ADMIN - Plant and Equipment (Capital)		1NGN CEO Vehicle 2018(2)		53,040.00	51,592.73	Torre Evans	●							
112	ADMIN - Plant and Equipment (Capital)		1NGN CEO Vehicle 2019		49,440.00	48,438.27	Torre Evans	●							
113	ADMIN - Plant and Equipment (Capital)		1NGN CEO Vehicle 2019(2)		49,440.00	-	Torre Evans	●							
114	ADMIN - Plant and Equipment (Capital)		ONGN EMCCS Vehicle 2018(2)		35,251.00	-	Torre Evans	●							
115	ADMIN - Plant and Equipment (Capital)		ONGN EMCCS Vehicle 2019		34,651.00	-	Torre Evans	●							
116	ADMIN - Plant and Equipment (Capital)		002 NGN MF Vehicle 2018		25,000.00	21,803.57	Torre Evans	●							
117	COMMUNITY - Plant & Equipment (Capital)		NGN 0 MLC Vehicle 2018		25,000.00	21,567.73	Torre Evans	●							
118			Great Southern Regional Business Association	Donation of \$18,551.61	18,551.00	-	Dale Stewart	●							

10.3.3 PROPOSED SALE OF LAND LOT 1224 (NUMBER 45) FORREST STREET NARROGIN ASSESSMENT A186100- DUE TO UNPAID RATES

File Reference	A186100
Disclosure of Interest	Neither the Author nor Authorising Officer have any Impartiality, Financial or Proximity Interest that requires disclosure
Applicant	Shire of Narrogin
Previous Item Numbers	Nil
Date	3 December 2018
Author	Toni Reitmajer – Finance Officer Rates
Authorising Officer	Frank Ludovico – Executive Manager Corporate and Community Services
Attachments	
1. Locality Plan	

Summary

Council is requested to utilise AMPAC Debt Recovery Services to sell land located at 45 Forrest Street Narrogin, under section 6.64 of the Local Government Act 1995, which is in arrears by more than three (3) years. The outstanding current balance is \$10,222.75. It is anticipated that there will be disposal costs of approximately \$5,000.

Background

The property has rates outstanding in excess of the requirement minimum of three years. The Ratepayer has been served with General Procedure Claims (GPC) and Property Seizure and Sale Order Goods (PSSO). The seizure of goods order has not been successful with the Bailiff unable to seize goods to the value of the debt, on various attempts. Due to periods of incarceration, the owner of the property has an elected Power of Attorney, who currently resides in New Zealand. Power of Attorney has provided the necessary documentation and requested information of the outstanding debt but to date no attempts from the owner or the Power of Attorney have been made to enter into any kind of payment arrangement for the payment of the balance owing.

Comment

Every effort has been made to contact the property owner and subsequently the Power of Attorney, to clear the debt, with no success.

Since 2014 the original rates notices have been issued to the current property owner, final notices and demand letters from the Shire's debt collection agencies Austral Mercantile and AMPAC to the last known addresses of the owner and various other addresses. General Procedure Claims (summons) have also been issued on our behalf and have been served on the residents of the property, along with Judgement Default and Property Seizure of Goods, with no success.

A title search of the property has confirmed that the ownership is still in the name of the ratepayer with a mortgage. Subsequent letters have been issued to the mortgagee requesting assistance under the mortgage terms and conditions, which have also been unsuccessful.

Extensive investigation and debt collection has been continually conducted on this property with no results to clear the debt. All efforts have now been exhausted.

An appraisal of the property from Ray White Narrogin has been provided with an estimated sale value of \$150,000.

Consultation

Consultation has taken place by the Rates Officer with the following:

- Austral Mercantile
- AMPAC Debt Recovery
- Baycorp (WA) Pty Ltd
- Price Sierakowski Corporate Solicitors
- National Australia Bank
- Ray White Real Estate Narrogin
- Shire of Narrogin, Manager Finance
- Shire of Narrogin, Executive Manager - Corporate & Communities Services

Statutory Environment

Section 6.64(1) of the Local Government Act 1995 provides that:

“If any rates or service charges due to a local government in respect of any rateable land have been unpaid for at least three (3) years, the local government may, in accordance with the appropriate provisions of this Subdivision, take possession of the land and hold as against a person having an estate or interest on the land and –

(b) sell the land and;-.”

Section 6.68(1) of the Local Government Act 1995 prevents the local government from exercising the power of sale unless the local government has at least once attempted to recover money due to it, under 6.56 of the Local Government Act 1995.

In order to take possession of the property and proceed with its sale, Council must cause notice requiring the payment of rates under Schedule 6.3 of the Local Government Act 1995.

Such notice is also to be served on any party with an interest in the land. This includes the mortgagee and is to be posted on the Shire official notice board for a period of not less than 35 days. It at the expiration of three (3) months from the date of issue of this notice the rates remain unpaid, the Shire of Narrogin may proceed with selling the land by public auction, with such auction to occur not more than 12 months from date of the notice.

If the matter takes this course and the property is sold by public auction, under Clause 5 of the Schedule 6.3 of the Local Government Act 1995, the outstanding rates, any additional legal expenses and the cost of the sale of incidental to the sale of the property can be recovered by the Shire in the event of the owners or associated parties making a claim.

If there are surplus funds from the sale of the property, and are not claimed after 12 months after the sale, the residual funds are to be paid to the Supreme Court under Section 99 of the Trustees Act 1962.

The Department of Local Government and Communities – Local Government Operational Guidelines Number 22 – May 2012 “Possession of Land for Recovery of Rates and Service Charges”, has been used to develop this item.

Policy Implications

Nil

Financial Implications

The recovery of these rates will reduce our outstanding rates debtors, therefore providing cash flow for Council activities.

It is proposed to use AMPAC Debt Recovery Services (our current WALGA preferred Debt Collection Agency) to process this matter. Anticipated cost is approximately \$5,000. This will be recoverable through the sale of the property.

Should there not be sufficient funds to clear the debt the following options are available to Shire:

- Section 6.47 of the Local Government Act 1995 allows a local government to waive (by absolute majority) rates at any time, including after they have been raised.
- Section 6.44(1) If Council chose not to waive any rates left owing after a sale for non-payment, the amount owing would follow the land to the new owner.
- Clause 3.6 of Local Government Guidelines Number 22 and Section 6.71 Local Government Act 1995 if the land remains unsold an option is to have it transferred to the Local Government or the Crown.

Strategic Implications

Shire of Narrogin Strategic Community Plan 2017-2027	
Objective	4. Civic Leadership Objective (Continually enhance the Shire's organisational capacity to service the needs of a growing community)
Outcome:	4.1 An efficient and effective organisation
Strategy:	4.1.1 Continually improve operational efficiencies and provide effective services

Voting Requirements

Simple Majority

OFFICERS' RECOMMENDATION AND COUNCIL RESOLUTION 1218.132

Moved: Cr Seale

Seconded: Cr Ward

That, with respect to Proposed Sale of Land Lot 1224 (Number 45) Forrest Street Narrogin, due to unpaid rates, Council, pursuant to section 6.64(1)(b) of the Local Government Act 1995, proceed with the sale of 45 Forrest Street Narrogin (Assessment Number A186100), to recover rates and charges in arrears of three (3) or more years.

CARRIED 8/0

**PROPOSED SALE OF LAND LOT 1224 (NUMBER 45) FORREST STREET NARROGIN ASSESSMENT
A186100- DUE TO UNPAID RATES**



10.3.4 DRAFT COMPLAINTS MANAGEMENT POLICY

File Reference	13.5.4
Disclosure of Interest	Neither the Author nor Authorising Officer have any Impartiality, Financial or Proximity Interest that requires disclosure.
Applicant	Shire of Narrogin
Previous Item Numbers	Nil
Date	7 December 2018
Author	Niel Mitchell – Governance Consultant
Authorising Officer	Frank Ludovico – Executive Manager Corporate & Community Services
Attachments	<ol style="list-style-type: none">1. Draft Complaints Management Policy2. Customer Service Charter

Summary

Council is requested to consider endorsing the draft Complaints Management Policy as per Attachment 1.

Background

The policy is intended to provide guidance for staff in dealing with complaints in a consistent and open way, that is in accordance with the Customer Service Charter.

Comment

Dealing with complaints can be challenging, especially where the complainant is confrontational or regular.

Complaints can be a useful tool for improvement or to highlight areas of concern or inadequacy. At the same time it should be recognised that not every complaint is justified or is automatically within the local government's legal capacity.

As a policy, it cannot be enforced on members of the public, but is an instruction to staff about how they are to administer or manage the issues.

The policy also provides the Chief Executive Officer with the authority to deal with aggressive or vexatious complainants. Staff have a right to feel safe and to not be bullied under the Occupational Safety and Health Act, and the Ombudsman's guidelines recognises that there are some complaints that will be constantly raised absorbing a lot of time resources, and creating disruption.

Accordingly, the policy provides staff with the processes of how to deal with complaints, and also the direction to pursue should a complaint exceed their capacity or role.

Consultation

Executive Management Team

Statutory Environment

None

Policy Implications

Adoption of new policy

Financial Implications

Nil

Strategic Implications

Shire of Narrogin Strategic Community Plan 2017-2027	
Objective	4. Civic Leadership Objective (Continually enhance the Shire's organisational capacity to service the needs of a growing community)
Outcome:	4.1 An efficient and effective organisation
Strategy:	4.1.1 Continually improve operational efficiencies and provide effective services
Strategy:	4.1.2 Continue to enhance communication and transparency
Outcome:	4.2 An employer of choice
Strategy:	4.2.1 Provide a positive, desirable workplace

Voting Requirements

Simple Majority

OFFICERS' RECOMMENDATION AND COUNCIL RESOLUTION 1218.133

Moved: Cr Seale Seconded: Cr Bartron

That with respect to the draft Complaints Management Policy, Council adopt the Policy as per Attachment 1.

CARRIED 8/0

3.9 Complaints Management

Statutory context N/A

Corporate context N/A

History Adopted _____

Policy Statement

Objectives

1. To develop a structured systematic approach to dealing with complaints received by the Shire of Narrogin from external persons.
2. To assure the community that complaints may be made without fear of recrimination and that all complaints will be promptly dealt with and a (written if required) response will be given setting out the answer to the complaint providing reasons, where appropriate.
3. To have complaints dealt with efficiently by an appropriate employee with minimal referral.
4. To use complaints statistics to improve the effectiveness and efficiency of Shire operations.

Definition

5. A complaint is –
“an expression of dissatisfaction made to or about an organization, related to its products, services, staff or the handling of a complaint, where a response or resolution is explicitly or implicitly expected or legally required”
(as defined by the *AS/NZS 10002-2014 Guidelines for Complaint Management in Organisations*).

Policy

6. The Shire of Narrogin recognises the right of its customers to make complaints about services or service delivery, and will make it a priority to address those complaints and rectify unsatisfactory consequences.
7. The Council and its staff will be open and honest in its dealings with customers.
8. When unable to satisfy the complaint, an explanation will be provided in “plain English” why, for legislative/legal reasons, cost constraints or some other matter beyond its control, it is unable to act in accordance with a complainant’s request.
9. The Shire recognises that good complaints handling is an integral part of customer service and provides an effective way of reviewing performance and monitoring standards.
10. The Shire may determine to take the following courses of action –
 - a) take no further action and advise the complainant of the reason/s;
 - b) determine the complaint by use of appropriate strategies such as, but not limited to, mediation, informal discussion or negotiation;
 - c) discontinue the assessment in circumstances where it becomes evident that the matter would be referred to another body or person and advise the complainant accordingly.

Confidentiality

11. Complainants have the right to expect that their privacy will be respected when making a complaint or having a complaint investigated. Personal information related to the complaint will be kept confidential in accordance with the *Freedom of Information WA Act 1992*.
12. All complaints are treated confidentially, unless required by law or the complainant provides their permission to release information.
13. A complaint against an employee is considered confidential under the *Freedom of Information Act 1992* and the complainant will not be advised of the outcome, unless required by law.

Application

14. Complaints that are to be dealt with under this policy include, but are not necessarily limited to, expressions of dissatisfaction regarding –
 - a) decisions made by Council or staff;
 - b) inappropriate behaviour of staff or members such as rudeness, discrimination or harassment;
 - c) the standard of works or services provided by the local government;
 - d) the standard or condition of a facility provided by the local government; and
 - e) failure of the local government to comply with the Local Government Act, Council policies, local laws and other laws administered by the local government.
15. The following issues are not regarded as complaints and will not be dealt with under this policy –
 - a) requests for services;
 - b) compliance enforcement action;
 - c) a civic dispute between private individuals;
 - d) a petition;
 - e) requests for information or explanations of policies and/or procedures;
 - f) the lodging of a formal objection or appeal in accordance with the Local Government Act and other Acts or in accordance with Council policies or standard procedures; and
 - g) the lodging of a submission in response to an invitation for comment.
16. Complaints regarding elected members are to be directed to the CEO who is responsible for the initial investigation and administrative responses. Matters that may require disciplinary action are to be referred to the Shire President and dealt with under the Council's Code of Conduct.
17. Complaints from Councillors, the Ombudsman, the Local Government Department or from Members of Parliament shall be referred to, and dealt with by, the CEO unless the complaints relates to the CEO whereupon the complaint will be dealt with by the Shire President.

Guidelines

18. Any person or their representative can lodge a complaint.
19. Complaints will be accepted in writing, in person, by facsimile transmission, by email or by telephone. If a verbally received complaint alleges a criminal offence, corruption or other serious matter, the receiving officer is to advise the complainant that the matter must be submitted in writing.
20. Complainants are to be advised that anonymous complaints may not be processed as it is possible that they may be mischievous or vexatious. Depending on the nature of the complaint, it will be at the discretion of the receiving officer to act or refer the complaint or not to deal with the complaint.
21. When any complaint is made, other than a complaint referred to in clauses 16 or 17, the designated receiving officer shall, within the limit of their authority, attempt to satisfy the complainant as soon as possible. If a complainant cannot be satisfied immediately, or on the same day, the designated receiving officer shall immediately issue to the complainant a written acknowledgement of the

complaint and if need be, refer to the complaint and a copy of the acknowledgement to a senior employee, or the CEO, as is appropriate, for investigation and determination of the complaint.

22. The standard response times when dealing with complaints are those in the Customer Service Charter.
23. Where a complainant is advised of a likely delay to the handling of the complaint and the complaint is not finalised within a reasonable period of time, the complainant is to be provided with status reports from time to time until the complaint is satisfied.
24. The CEO shall establish and maintain an appropriate record of all complaints. The record will provide the following –
 - a) nature of each complaint;
 - b) services or facilities about which the complaints are made;
 - c) outcomes; and
 - d) other relevant information.
25. The designated receiving officer of any complaint shall be responsible for ensuring that all details pertaining to the complaint are recorded in the system established under clause 24.

Outcomes

26. Where a complaint has been investigated and found to be justified, the relevant officer who dealt with the complaint will ensure that the remedy is carried out, will advise the complainant that the Shire does acknowledge substance in the complaint and the specific action that will be taken by the Shire to respond to the circumstances of the complaint. The officer will, if appropriate, make follow-up contact with the complainant to ensure that the complaint has been resolved satisfactorily.
27. Where a complaint may identify the need for a review of procedures to prevent re-occurrences, relevant staff are to implement any required changes which they feel appropriate. If the matter cannot be easily remedied by the officer, he or she must liaise with his/her Manager or the CEO to agree on a course of action.
28. Where the complaint identifies a need for a change of Council policy in a particular area or a need for additional resources, the matter shall be referred to Council as early as practicable.
29. Where appropriate or necessary, the CEO or other officer may refer the complaint to an external agency having jurisdiction in the matter.

Dealing with unreasonable complainant conduct

30. An unreasonable complainant is defined as the following –
 - a) a rude, angry and harassing customer;
 - b) an aggressive customer;
 - c) habitual or obsessive behaviour which may include –
 - i) cannot 'let go' of their complaint;
 - ii) cannot be satisfied despite the best efforts of the Shire;
 - iii) makes unreasonable demands on the local government where resources are substantially and unreasonably diverted away from its other functions or are unfairly allocated.
31. The Shire may restrict, withhold or withdraw the provision of service to unreasonable complainants by taking one of the following actions –
 - a) require the complainant to make an appointment to meet with employees;
 - b) limit all future dealings to writing;

- c) only respond to future correspondence which provides significant new information about the complaint or raises new issues which the Shire believes warrant fresh action; and
- d) direct all contact to be through a specific employee or area.

32. The decision to determine an unreasonable complainant or to restrict, withhold or withdraw contact with the Shire will only be made by the Chief Executive Officer.

– End of Policy

Notes

WE VALUE AND ENCOURAGE your feedback

KEY PRINCIPLES

We set achievable goals and work with the community to maintain a reputation of openness, honesty and accountability.

In doing so, we:

- respect the points of view of individuals and groups;
- build on existing community involvement; encourage community leadership;
- promote self-reliance and initiative;
- recognise and celebrate achievement;
- support the principles of social justice; and
- acknowledge the value of staff and volunteers.

Our employees are committed to providing customers with high quality service through access to consistent, accurate and relevant advice and information.

CUSTOMER SERVICE STANDARDS

Our employees will:

- identify themselves
- listen carefully to what you have to say
- be helpful, polite and courteous
- follow through on any commitments they make
- value and encourage your feedback.

Our information will be:

- easy to access
- accurate and consistent
- relevant and practical.

Our actions will:

- be fair and impartial
- be completed within a specified timeframe
- take your individual needs into consideration.

OUR COMMITMENT

We will:

- answer telephone calls promptly and respond to telephone messages by the end of the next working day
- respond to verbal queries within 5 working days
- respond to written queries within 10 working days
- respond to complaints within 10 working days
- update you on the progress of your query or complaint if a delay is likely
- acknowledge and rectify when an error has occurred
- honour the Shire of Narrogin's Code of Conduct
- comply with the Council's adopted Complaint Management Policy.

HOW TO MAKE A COMPLIMENT, SUGGESTION OR LODGE A WORKS REQUEST OR COMPLAINT

We encourage you to help us improve our products, facilities and services by contacting us to:

- compliment us on the services we do well
- offer suggestions on what we might do differently
- send a complaint and tell us what we can do better.

WHAT IS A ...

...compliment?

An expression of approval or praise about our products or services.

...suggestion?

An idea or proposal that you believe will help improve our products or services.

...complaint?

An expression of dissatisfaction about our products or services, or the complaints handling process itself, where you expect a response or resolution.

...works request?

If you need to report a problem or request service from the Shire in relation to one of our many services or facilities maintained by the Shire, please obtain or download our [Works Request Form](#).

WHEN TO LODGE A COMPLIMENT?

To help us to continue to deliver quality service, we encourage you to:

- acknowledge quality service with a simple 'thank you'
- acknowledge quality service with a letter, email or advice on our Facebook Page perhaps when you feel it appropriate and justified
- let us know so that we may acknowledge the employee in some small way.

You may wish to obtain or download our [Service Compliment / Complaint Form](#).

WHEN TO LODGE A COMPLAINT?

To help us provide assistance, we ask that you:

- try to resolve the issue before lodging a complaint by contacting the employee you initially dealt with
- clearly state your complaint and provide all relevant information
- treat our employees with respect and courtesy.

WHAT TO INCLUDE IN YOUR COMPLAINT

Your complaint should include details such as:

- who or what you are complaining about
- what you think has gone wrong
- how you have been affected
- when the issue occurred
- details of any telephone conversations and/or meetings
- copies of any relevant documents (e.g. letters)
- what you have done to try resolve the issue
- the outcome you are seeking.

You may wish to obtain or download our [Service Compliment / Complaint Form](#).

When we receive your complaint, we will:

- acknowledge that we have received your complaint
- keep your concerns confidential and discuss them only with the people who need to be involved
- consider your complaint carefully
- treat you fairly and impartially with courtesy and respect
- keep you informed about the progress of your complaint
- explain to you the reasons for any decision we make
- tell you about any action we have taken
- use your complaint to help improve our products or services.

TAKING A COMPLAINT FURTHER

If you have a complaint, that you do not wish to raise directly with us, or after dealing with us you are not satisfied with the outcome, you may refer the matter to the Ombudsman Western Australia.

Telephone (Country callers): 1800 117 000

Email: mail@ombudsman.wa.gov.au

Further information can be obtained by visiting:
www.ombudsman.wa.gov.au

MISCONDUCT

If your complaint involves alleged **minor** misconduct of a Shire employee, then you may wish to refer your complaint direct to the Public Sector Commission.

If your complaint involves alleged **serious** misconduct of a Shire employee, then you may wish to refer your complaint direct to the Corruption and Crime Commission.

If your complaint involves an alleged **minor** misconduct of an elected member, then you are encouraged to contact the Chief Executive Officer or the Rules of Conduct Complaints Officer at the Shire.

If your complaint involves an alleged **serious** misconduct of an elected member, then you are encouraged to contact the Department of Local Government, Sport and Cultural Industries.

<https://www.dlgsc.wa.gov.au/localgovernment/forcouncils/Pages/Breaches-of-the-Local-Government-Act.aspx>

The definitions of what constitutes **minor** and **serious** misconduct is detailed on the following websites:

<https://publicsector.wa.gov.au>

<https://www.ccc.wa.gov.au>

Customer Service Charter

SHIRE OF NARROGIN

CONTACT US

For all compliments, suggestions concerns or complaints, please contact:

Shire of Narrogin
Executive Manager
Corporate & Community Services

Telephone
(08) 9890 0900

Email
enquiries@narrogin.wa.gov.au

Web
www.narrogin.wa.gov.au

Post
Shire of Narrogin
PO Box 1145
Narrogin WA 6312

In Person
89 Earl Street, Narrogin



10.4 OFFICE OF THE CHIEF EXECUTIVE OFFICER

The CEO reminded Elected Members that he has declared a financial interest in the following item.

10.4.1 CONDUCT OF 2019 LOCAL GOVERNMENT ELECTION

File Reference	NAM16895 – 14.8.1 ICR 1815623
Disclosure of Interest	The Author declares a Financial and Impartiality Interest in that the officer is the default Returning Officer in the event that the Council does not make a declaration.
Applicant	Western Australian Electoral Commission
Previous Item Numbers	10.2.163 of 20 December 2016
Date	18 September 2018
Author	Dale Stewart – Chief Executive Officer
Authorising Officer	Dale Stewart – Chief Executive Officer
Attachments	1. Letter from Western Australian Electoral Commission dated 19 October 2018

Summary

The purpose of this report is to seek the approval of Council to conduct an election under the *Local Government Act 1995*, section 4.11 on 19 October 2019 as a postal election of four Councillors for the District of Narrogin (in entirety – no wards) and to appoint the Western Australian Electoral Commission (WAEC) to conduct the Election.

Background

The 2017 Shire of Narrogin Shire President, Urban and Rural Elections were successfully conducted by the WAEC.

Comment

It is presented to Council to consider the proposal from the Electoral Commission to facilitate the Ordinary 2019 Election process, on behalf of Council by way of a postal election.

To facilitate the process a formal request to the Electoral Commissioner is required for the commitment to be confirmed prior to the election cycle commencing.

A quote has been provided from the Electoral Commission for four (4) councillor vacancies (whole of District).

The four Elected Members positions up for vacancy are those currently occupied by:

- Councillor Colin Ward
- Councillor Paul Schutz
- Councillor Murray Fisher
- Councillor Nathan Walker

The continuing Elected Members convert to being of 'no ward' status from the October 2019 Election.

Note: This Election will see the removal of the ward system for the first time, pursuant to clause 5 of the Local Government (Narrogin – Merger) Order 2016.

A copy of the quote for \$24,000 including GST to conduct the election, as postal ballots, with an on-site count is attached. The quote includes all statutory advertising.

It should be noted that should Council choose to return the 2019 Election to "in-person" and conducted by staff, the implications for this decision is that staff time committed during the election process will be heavy and other projects will be delayed. It is also a considerable benefit to have the experience of the Commission facilitating the process and to allow Council and staff to be at arm's length to the process.

Consultation

The WAEC has written to the Shire of Narrogin offering to undertake the 2019 Election.

No additional consultation on the matter is deemed necessary.

Statutory Environment

The provision of the Local Government Act 1995, section 4.20 and 4.61 relates and must be resolved at least 80 days prior to an Election.

In the absence of the Council making a determination as to the Returning Officer (RO), the Chief Executive Officer is the RO, pursuant to section 4.20 (1).

Policy Implications

There are no relevant nor proposed Council Policies that relate to the request.

The Council's practice, since the merger, has been to appoint the WAEC and to conduct the Election as a Postal Election.

Financial Implications

If Council chooses to have the 2019 Election facilitated by the Electoral Commission, there will be a cost implication of \$24,000 inc GST and this should be provided for in the 2019/2020 Adopted Budget.

In addition, the Shire of Narrogin must also meet the associated cost of additional non-statutory advertising and provision of one staff member to work at the polling place on Election Day.

Should Council not proceed with the Electoral Commission quotation, the staff time allocated to the process and advertising cost would be similar to the quotation provided and other projects would be delayed, with perceptions of independence potentially questioned.

Strategic Implications

To have the process facilitated by the Electoral Commission will assist in encouraging greater voter input into the election due to the process being conducted via a postal election.

Shire of Narrogin Strategic Community Plan 2017-2027	
Objective:	4. Civic Leadership Objective (Continually enhance the Shire's organisational capacity to service the needs of a growing community)
Outcome:	4.1 An efficient and effective organisation
Strategy:	4.1.2 Continue to enhance communication and transparency

Voting Requirements

Absolute Majority

OFFICERS' RECOMMENDATION AND COUNCIL RESOLUTION 1218.134

Moved: Cr Seale Seconded: Cr Wiese

That, with respect to the conduct of the 2019 Shire of Narrogin Ordinary Local Government Election, Council:

1. Accept the quotation provided by the Western Australian Electoral Commission of \$24,000 inc GST to conduct the election for four (4) Councillors and ensure this amount is provided for in developing the 2019/20 Budget;
2. Declare, in accordance with section 4.20(4) of the *Local Government Act 1995*, the Electoral Commissioner to be responsible for the conduct of the Election together with any other elections or polls which may be required; and
3. Decide, in accordance with section 4.61(2) of the *Local Government Act 1995*, that the method of conducting the election will be as a postal election.

**CARRIED 8/0
BY ABSOLUTE MAJORITY**



LGE 028

Mr Dale Stewart
Chief Executive Officer
Shire of Narrogin
PO Box 1145
NARROGIN WA 6312

Shire of Narrogin RECEIVED	
Directed to	<u>Dale/Frank</u>
	24 OCT 2018
Ref No	<u>ICR1815623</u>
Property File	
Subject File	<u>13.4.3</u>
Ref	

Dear Mr Stewart

Local Government Ordinary Election: 2019

The next local government ordinary elections are being held on 19 October 2019. While this is still some distance in the future, I have enclosed an estimate for your next ordinary election to assist in your 2019/2020 budget preparations.

The estimated cost for the 2019 election if conducted as a postal ballot is \$24,000 inc GST, which has been based on the following assumptions:

- 3,350 electors
- response rate of approximately 40%
- 4 vacancies
- count to be conducted at the offices of the Shire of Narrogin
- appointment of a local Returning Officer
- regular Australia Post delivery service to apply for the lodgement of the election packages.

An additional amount of \$670 will be incurred if your Council decides to opt for the Australia Post Priority Service for the lodgement of election packages. The Commission is of the view that the regular service is adequate for outgoing mail for most local governments, particularly in the metropolitan area.

Costs not incorporated in this estimate include:

- any legal expenses other than those that are determined to be borne by the Western Australian Electoral Commission in a Court of Disputed Returns
- one local government staff member to work in the polling place on election day
- any additional postage rate increase by Australia Post.

The Commission is required by the *Local Government Act* to conduct local government elections on a full cost recovery basis and you should note that this is an estimate only and may vary depending on a range of factors including the cost of materials or number of replies received. The basis for charges is all materials at cost and a margin on staff time only. Should a significant change in this figure become evident prior to or during the election you will be advised as early as possible.

The current procedure required by the Act is that my written agreement has to be obtained before the vote by Council is taken. To facilitate the process, you can take this letter as my agreement to be responsible for the conduct of the ordinary elections in 2019 for the Shire of Narrogin in accordance with section 4.20(4) of the *Local Government Act 1995*, together with any other elections or polls that may also be required. My agreement is subject to the proviso that the Shire of Narrogin also wishes to have the election undertaken by the Western Australian Electoral Commission as a postal election.

In order to achieve this, your council would need to pass the following two motions by absolute majority:

- Declare, in accordance with section 4.20(4) of the *Local Government Act 1995*, the Electoral Commissioner to be responsible for the conduct of the 2019 ordinary elections together with any other elections or polls which may be required
- Decide, in accordance with section 4.61(2) of the *Local Government Act 1995* that the method of conducting the election will be as a postal election.

I look forward to conducting this election for the Shire of Narrogin in anticipation of an affirmative vote by Council. If you have any further queries please contact Phil Richards Manager, Election Events on 9214 0400.

Yours sincerely



David Kerlake
ELECTORAL COMMISSIONER

19 October 2018

As the following item could require a confidential discussion, the Elected Members decided to close the meeting to the public.

COUNCIL RESOLUTION 1218.135	
Moved: Cr Seale	Seconded: Cr Ward
That, with respect to the Chief Executive Officer performance appraisal that the meeting be closed to the public pursuant to Section 5.23(2)(a) of the Local Government Act 1995.	
CARRIED 8/0	

The CEO and staff left the meeting at 8:37 pm

10.4.2 CHIEF EXECUTIVE OFFICER PERFORMANCE APPRAISAL

File Reference	Personal File
Disclosure of Interest	The Author has an obvious Impartiality and Financial that requires disclosure as it relates to his employment contract and conditions of employment.
Applicant	Dale Stewart, Chief Executive Officer
Previous Item Numbers	Nil
Date	10 December 2018
Author	Dale Stewart – Chief Executive Officer
Authorising Officer	Dale Stewart – Chief Executive Officer
Attachments	
<ol style="list-style-type: none"> 1. Signed Contract of Employment (Confidential Separate Cover) 2. Report on the CEO Appraisal, compiled by the Shire President and Deputy Shire President (Confidential Separate Cover) 	

Summary

The Council is asked to consider the confidential report compiled by the Shire President and Deputy Shire President with respect to the conclusion of the Chief Executive Officer’s 6-month probationary period.

Background

The Chief Executive Officer was employed on a five year performance based fixed term contract commencing 31 May 2018.

The officer's tenure is subject to a six-month probationary period, concluding on 30 November 2018, giving rise to the attached report on the CEO Appraisal, undertaken by elected members compiled by the Shire President and Deputy Shire President.

Comment

The Council has the following options available to it at this time:

Employment Contract Options

- Cessation with four weeks' notice or notice in lieu;
- Confirmation of employment for the five-year term of the contract; or
- Extension of probation by between one to three months.

A decision of the Council is required at the Council Meeting of 19 December 2018 to guide the employee.

Consultation

All Elected Members should be consulted on the matter by the Shire President and Deputy Shire President.

The Chief Executive Officer should be consulted on any proposed variations to the employment contract or any proposed Key Performance Indicators (KPIs).

Statutory Environment

The Chief Executive Officer's contract, employment law and contract law guide the Council's consideration of the matter.

Relevant clauses of the Contract include:

"Clause 2.3 Initial Probationary Period

(1) The Chief Executive Officer's employment will be subject to an initial probationary period of six (6) months, as specified in item 7 of Schedule 2

(2) After an assessment of your performance, the Council may elect to extend the probationary period by an additional one (1) to three (3) months, but no longer than three (3) months.

(3) The Council or the Chief Executive Officer may terminate this Contract without reason at any time during the initial or extended Probationary Period:

(a) by the Chief Executive Officer or the Council giving 4 weeks' notice;

or

(b) immediately by the Local Government paying to the Chief Executive Officer 4 weeks' salary in lieu of notice under this clause.

(4) If the Local Government is satisfied with Your performance at the end of the Probationary Period, Your employment will be confirmed."

Council should seek independent legal or industrial relations advice (such as but not limited to McLeod’s Solicitors and WALGA respectively) should it feel the need to do so, but only via resolution.

Policy Implications

There are no relevant nor proposed Council Policies that relate to the matter.

Financial Implications

Consideration of the financial implications as detailed on the confidential schedule, if any.

Strategic Implications

The proposed contribution is supported by the following components of the Shire of Narrogin Strategic Community Plan:

Objective	4. Civic Leadership Objective (Continually enhance the Shire's organisational capacity to service the needs of a growing community)
Outcome:	4.1 An efficient and effective organisation
Strategy:	4.1.1 Continually improve operational efficiencies and provide effective services
Strategy:	4.1.2 Continue to enhance communication and transparency
Outcome:	4.2 An employer of choice
Strategy:	4.2.1 Provide a positive, desirable workplace

Voting Requirements

Simple Majority

OFFICERS’ RECOMMENDATION

That, with respect to the performance appraisal of the Chief Executive Officer, the Council receive the confidential report and endorse the schedule of recommendations from the Shire President and Deputy Shire President contained therein.

COUNCIL RESOLUTION 1218.136

Moved: Cr Seale Seconded: Cr Wiese

That, with respect to the performance appraisal of the Chief Executive Officer, the Council receive the confidential report and endorse the following recommendations from the Shire President and Deputy Shire President:

1. Confirmation of employment for the five year term of the contract;
2. Endorse the KPI’s as listed in the report.

CARRIED 8/0

COUNCIL RESOLUTION 1218.137

Moved: Cr Seale Seconded: Cr Ward

That the meeting be re-opened to the public.

CARRIED 8/0

9:00 pm – Officers returned to the meeting

11. ELECTED MEMBERS' MOTIONS OF WHICH PREVIOUS NOTICE HAS BEEN GIVEN

Nil

12. NEW BUSINESS OF AN URGENT NATURE APPROVED BY THE PERSON PRESIDING OR BY DECISION OF THE MEETING

Nil

13. CLOSURE OF MEETING

There being no further business to discuss, the Presiding Member declared the meeting closed at 9:04 pm and pursuant to Resolution 1118.122 of 28 November 2018, reminded Councillors of the next Ordinary Meeting of the Council, scheduled for 7.00 pm on 27 February 2019 at this same venue.