



AGENDA

ORDINARY COUNCIL MEETING

23 June 2021

NOTICE OF ORDINARY MEETING OF COUNCIL

Dear Elected Member & Community Members

Pursuant to Resolution 1020.012 of 27 October 2020, an Ordinary Meeting of the Shire of Narrogin will be held on 23 June 2021, in the Shire of Narrogin Council Chambers, 89 Earl Street, Narrogin, commencing at 7:00 pm.

A handwritten signature in black ink, appearing to read 'Dale Stewart'.

Dale Stewart
Chief Executive Officer

Acknowledgement of Noongar People

The Shire of Narrogin acknowledges the Noongar people as traditional custodians of this land and their continuing connection to land and community. We pay our respect to them, to their culture and to their Elders past and present.

Naatj ngiyan Birdiya Gnarojin kep unna nidja Noongar Moort ngaala maya nidja boodjera baarlap djoowak karlerl koolark. Ngalak niny ngullang karnan balang Bibolman baalap borong koora wer boorda.

Electronic copies of minutes and agendas are available for download from the Shire of Narrogin website www.narrogin.wa.gov.au

Alternative formats are also available upon request, including large print, electronic format (disk or emailed), audio or Braille



Shire of
Narrogin
Love the life

STRATEGIC COMMUNITY PLAN

2017-27

SNAPSHOT

VISION

A leading regional economic driver and a socially interactive and inclusive community.

MISSION

Provide leadership, direction and opportunities for the community.

KEY PRINCIPLES

In achieving the Vision and Mission, we will set achievable goals and work with the community to maintain a reputation of openness, honesty and accountability. In doing so we will:

- Respect the points of view of individuals and groups;
- Build on existing community involvement;
- Encourage community leadership;
- Promote self-reliance and initiative;
- Recognise and celebrate achievement;
- Support the principles of social justice; and
- Acknowledge the value of staff and volunteers.

OUR VALUES

Care with Trust & Teamwork

Caring - We display kindness and concern for one another and our community

Accountability - We accept responsibility for our actions and outcomes

Respect - We treat everyone how we would like to be treated

Excellence - We go the extra mile to deliver outstanding services

Trust - We share without fear of consequences

Team Work - We work together for a common goal

ECONOMIC



Support growth and progress, locally and regionally...

Growth in revenue opportunities

- Attract new industry, business, investment and encourage diversity whilst encouraging growth of local business
- Promote Narrogin and the Region
- Promote Narrogin's health and aged services including aged housing

Increased Tourism

- Promote, develop tourism and maintain local attractions

An effective well maintained transport network

- Maintain and improve road network in line with resource capacity
- Review and implement the Airport Master Plan

Agriculture opportunities maintained and developed

- Support development of agricultural services

SOCIAL



Provide community facilities and promote social interaction...

Provision of youth services

- Develop and implement a youth strategy

Build a healthier and safer community

- Support the provision of community security services and facilities
- Advocate for mental health and social support services
- Continue and improve provision of in-home care services

Existing strong community spirit and pride is fostered, promoted and encouraged

- Develop and activate Sport and Recreation Master Plan
- Engage and support community groups and volunteers
- Facilitate and support community events
- Provide improved community facilities (eg library/recreation)
- Encourage and support continued development of arts and culture

Cultural and heritage diversity is recognised

- Maintain and enhance heritage assets
- Support our Narrogin cultural and indigenous community

A broad range of quality education services and facilities servicing the region

- Advocate for increased education facilities for the region
- Advocate for and support increased education services

ENVIRONMENT



Conserve, protect and enhance our natural and built environment...

A preserved natural environment

- Conserve, enhance, promote and rehabilitate the natural environment

Effective waste services

- Support the provision of waste services

Efficient use of resources

- Increase resource usage efficiency

A well maintained built environment

- Improve and maintain built environment

CIVIC



Continually enhance the Shire's organisational capacity to service the needs of a growing community...

An efficient and effective organisation

- Continually improve operational efficiencies and provide effective services
- Continue to enhance communication and transparency

An employer of choice

- Provide a positive, desirable workplace

DISCLAIMER

Council and Committee agendas, recommendations, minutes and resolutions are subject to confirmation by the Council or Committee and therefore, prior to relying on them, one should refer to the subsequent meeting of Council or the Committee with respect to their accuracy.

No responsibility whatsoever is implied or accepted by the Shire of Narrogin for any act, omission or statement or intimation occurring during Council/Committee meetings or during formal/informal conversations with staff.

The Shire of Narrogin disclaims any liability for any loss whatsoever and howsoever caused arising out of reliance by any person or legal entity on any such act, omission or statement or intimation occurring during Council/Committee meetings or discussions. Any person or legal entity who acts or fails to act in reliance upon any statement does so at that person's or legal entity's own risk.

In particular and without derogating in any way from the broad disclaimer above, in any discussion regarding any planning application or application for a license, any statement or limitation or approval made by a member or officer of the Shire of Narrogin during the course of any meeting is not intended to be and is not taken as notice of approval from the Shire of Narrogin. The Shire of Narrogin warns that anyone who has an application lodged with the Shire of Narrogin must obtain and should only rely on WRITTEN CONFIRMATION of the outcome of the application, and any conditions attaching to the decision made by the Shire of Narrogin in respect of the application.

Please note that meetings may be recorded for minute taking purposes.

CONTENTS

Agenda Item	Page
1. OFFICIAL OPENING/ANNOUNCEMENT OF VISITORS	6
2. RECORD OF ATTENDANCE/APOLOGIES/APPROVED LEAVE OF ABSENCE	6
3. DECLARATION OF INTEREST BY ELECTED MEMBERS AND COUNCIL EMPLOYEES IN MATTERS INCLUDED IN THE MEETING AGENDA	6
4. RESPONSE TO PREVIOUS PUBLIC QUESTIONS TAKEN ON NOTICE	7
5. PUBLIC QUESTION TIME	7
6. APPLICATIONS FOR LEAVE OF ABSENCE	8
7. CONFIRMATION OF MINUTES OF PREVIOUS MEETINGS	8
8. ANNOUNCEMENTS BY THE PERSON PRESIDING WITHOUT DISCUSSION	8
9. PETITIONS, DEPUTATIONS, PRESENTATIONS OR SUBMISSIONS	8
10. MATTERS WHICH REQUIRE DECISIONS	9
10.1 DEVELOPMENT AND REGULATORY SERVICES	9
10.1.1 APPLICATION FOR PLANNING CONSENT: TOURISM ACCOMMODATION (USE NOT LISTED) AT VARIOUS LOTS (NO. 443) KILPATRICK ROAD, NOMANS LAKE	9
10.1.2 APPLICATION FOR PLANNING CONSENT: CONSULTING ROOMS (MEDICAL CENTRE) AT LOT 23 (SHOP 1. NO. 83) FEDERAL STREET, NARROGIN	105
10.2 TECHNICAL AND RURAL SERVICES	114
10.2.1 REVISED TEN YEAR FOOTPATH CONSTRUCTION PROGRAM 2021-2031	114
10.3 CORPORATE AND COMMUNITY SERVICES	119
10.3.1 SCHEDULE OF ACCOUNTS PAID – MAY 2021	119
10.3.2 MONTHLY FINANCIAL REPORTS – MAY 2021	151
10.3.3 PROPOSED 2021/22 FEES & CHARGES	172
10.3.4 RATES AND SUNDRY DEBTORS WRITE OFFS	195
10.4 OFFICE OF THE CHIEF EXECUTIVE OFFICER	197
10.4.1 DEED OF VARIATION TO LEASES – NARROGIN BOWLING CLUB & NARROGIN CROQUET CLUB	197
10.4.2 POLICY MANUAL – 2021 REVIEW	248
11. ELECTED MEMBERS' MOTIONS OF WHICH PREVIOUS NOTICE HAS BEEN GIVEN	472
12. NEW BUSINESS OF AN URGENT NATURE APPROVED BY THE PERSON PRESIDING OR BY DECISION OF THE MEETING	472
13. CLOSURE OF MEETING	472

ORDINARY COUNCIL MEETING

23 JUNE 2021

1. OFFICIAL OPENING/ANNOUNCEMENT OF VISITORS

The Presiding Member, President Ballard, declared the meeting open at 7:00 pm.

2. RECORD OF ATTENDANCE/APOLOGIES/APPROVED LEAVE OF ABSENCE

Elected Members (Voting)

Mr L Ballard – Shire President (Presiding Member)

Cr T Wiese – Deputy Shire President

Cr S Lushey – Via instantaneous communication

Cr M Fisher

Cr G Broad

Cr C Bartron

Cr J Early

Cr B Seale

Cr G Ballard

Staff

Mr D Stewart – Chief Executive Officer

Mr A Awang – Executive Manager Development & Regulatory Services

Mr T Evans – Executive Manager Technical & Rural Services

Mr F Ludovico – Executive Manager Corporate & Community Services

Ms C Thompson – Executive Assistant

Leave of Absence

Nil

Apologies

Absent

Visitors

3. DECLARATION OF INTEREST BY ELECTED MEMBERS AND COUNCIL EMPLOYEES IN MATTERS INCLUDED IN THE MEETING AGENDA

Name	Item No	Interest	Nature

4. RESPONSE TO PREVIOUS PUBLIC QUESTIONS TAKEN ON NOTICE

Nil

5. PUBLIC QUESTION TIME

Angela Wilson - Narrogin improvement ideas/suggestions

"Hi

Please direct this email to the appropriate person/persons to action.

I recently read in the Observer that council decided against removing the artwork on both entrances to town and replacing it with a rock wall. I am glad they did. For years on the Narrakine-Wandering Road we had a dilapidated wooden entry sign that was absolutely awful and now we have a reduced scale piece of artwork and a larger one on the great southern highway; both are beautiful and a pleasing entrance to town. Maybe when they are past their use-by date council should consider replacing them but not before.

To encourage tourists to town and to stay in town they need things to do. Below are some suggestions to consider.

What about funding for one of The Big Things of Australia – a BIG Echidna or Numbat – one that possibly could have a lookout or skywalk that one could climb to view the whole town? Something to put the town on the map so to speak.

The other thing Narrogin residents and tourists really need is a self-serve car, truck, boat, caravan and dog wash facility. It can use recycled water and be environmentally friendly. It would take minimal management if EFTPOS debit/credit cards were the only option (no cash used). Responsible youth or people with disabilities could be employed to refill items such as cloths etc. for sale. Surely we have some wealthy farmers or developers/entrepreneurs who would be interested in funding such an important venture which would be very well utilised and a great money spinner. A number of other country towns including Hopetoun have one and it is always busy.

We also recently lost our Target store and it needs to be replaced, preferably with a Best & Less or even a Kmart or BigW hub where items can be purchased in store or by Click & Collect. Young families need a store where they can buy clothing shoes and other items at a reasonable cost. Narrogin is a hub and is visited daily by residents from outlying towns who would appreciate and support such a store.

It would be appreciated if these items could be raised and discussed at the next council meeting.

Angela Wilson"

6. APPLICATIONS FOR LEAVE OF ABSENCE

The next meeting is scheduled for 28 July 2021.

7. CONFIRMATION OF MINUTES OF PREVIOUS MEETINGS

OFFICER'S RECOMMENDATION

That the minutes of the Ordinary Council Meeting held on 26 May 2021 be confirmed as an accurate record of the proceedings. (subject to the following correction:)

- Record of Attendance, Mr T Baldwin Rates Officer added to list of staff, L Nelson, C Pensini, J Pomykala and S Guy added as visitors.

8. ANNOUNCEMENTS BY THE PERSON PRESIDING WITHOUT DISCUSSION

9. PETITIONS, DEPUTATIONS, PRESENTATIONS OR SUBMISSIONS

Daniel Crossley – Narrogin Gridiron

10. MATTERS WHICH REQUIRE DECISIONS

10.1 DEVELOPMENT AND REGULATORY SERVICES

10.1.1 APPLICATION FOR PLANNING CONSENT: TOURISM ACCOMMODATION (USE NOT LISTED) AT VARIOUS LOTS (NO. 443) KILPATRICK ROAD, NOMANS LAKE

File Reference	A622
Disclosure of Interest	Neither the Author nor Authorising Officer have any Impartiality, Financial or Proximity Interests that requires disclosure.
Applicant	Planning Outcomes WA
Previous Item Numbers	Nil
Date	14 June 2021
Author	David Johnston – Planning Officer
Authorising Officer	Azhar Awang – Executive Manager Development and Regulatory Services
Attachments 1. Cover Letter 2. Site Plans, Floor Plans and Elevations 3. Wastewater Management System Design Proposal 4. Bushfire Management Plan	

Summary

Council's consideration is requested in regard to the proposed Tourism Accommodation on various lots at 443 Kilpatrick Road, Narrogin, for the purpose of public advertising in accordance with Clause 3.2.5 b).

The lots included in this application under the address, 443 Kilpatrick Road are as follows:

Address	Volume/Folio	Area m ²
Lot 6645	1705/523	647,927
Lot 6801		2,321,106
Lot 7056 (No. 363)		644,757
Lot 10634		411,882
Lot 11485		1,047,905
Lot 5092	1934/743	824,930
Lot 10845 (part)	1302/478	3,649,471
Lot 3	2659/390	214,232
Lot 4	2659/391	369,448
Lot 14845 (part)	1238/605	550,625

Background

On 14 May 2021, an Application for Planning Consent was received for the proposed Tourism Accommodation on various lots at 443 Kilpatrick Road, Narrogin. This proposal comprises five “tiny homes”. These “tiny homes” are essentially licensed caravans which are designed to be more aesthetically pleasing and include additional facilities than a regular caravan. Pictures and 3D images have been included in Attachments 1 and 2. These “tiny homes” will be positioned around the farm each on a separate lot and with their own water tank, parking space and ablution facilities. Also included in the application is four timber signs all measuring 900mm wide and 400mm high on a one metre high post. These will be located at each driveway entrance.

Consultation

The Application was discussed with the following staff:

- Building Surveyor;
- Environmental Health Officer;
- Manager Community, Leisure and Culture; and
- Executive Manager Development and Regulatory Services.

This report recommends that Council support the Application for the purpose of public advertising for a period of 21 days. The proposal is to be advertised on the Shire’s website, in the Shire Office, on the Shire’s Facebook page and in the Narrogin Observer in accordance with the Planning and Development (Local Planning Schemes) Regulations 2015.

Statutory Environment

The following Acts, Regulations and Schemes that apply to this item include:

- Former Shire of Narrogin – Local Planning Scheme No. 2;
- Planning and Development (Local Planning Schemes) Regulations 2015;
- Planning and Development Act 2005;
- Caravan Parks and Camping Grounds Regulations 1997.

Policy Implications

Nil

Financial Implications

An Application for Planning Consent Fee of \$1,280 has been paid to the Shire of Narrogin.

Strategic Implications

The Application directly relates to the Shire of Narrogin Tourism Strategy. The proposal is well aligned with strategy number 6 which states: *“Encourage the Development of Experiential Accommodation Options: Farm-stay, caravanning, camping (possibly glamping)”*

Shire of Narrogin Strategic Community Plan 2017-2027		
Objective	1.	Economic Objective (Support growth and progress, locally and regionally)
Outcome:	1.1	Growth in revenue opportunities

Strategy:	1.1.1	Attract new industry, business, investment and encourage diversity whilst encouraging growth of local business
Strategy:	1.1.2	Promote Narrogin and the Region
Outcome:	1.2	Increased Tourism
Strategy:	1.2.1	Promote, develop tourism and maintain local attractions
Objective	3.	Environment Objective (Conserve, protect and enhance our natural and built environment)
Outcome:	3.1	A preserved natural environment
Strategy:	3.1.1	Conserve, enhance, promote and rehabilitate the natural environment
Outcome:	3.4	A well maintained built environment
Strategy:	3.4.1	Improve and maintain built environment

Comment/Conclusion

Zoning

The various lots at 443 Kilpatrick Road, Narrogin, included in the Application are all zoned 'Farming' under the Former Shire of Narrogin Local Planning Scheme No. 2 (FSLPS2). The objectives of this zone are as follows:

"4.13 The Council intends the predominant form of farming activity in the Farming Zone will continue to be based on large farming units. It will generally be opposed to the fragmentation of farming properties through the process of subdivision.

4.13.2 Development: The Council shall not grant planning approval for any development that will in the opinion of the Council adversely affect the rural landscape or be contrary to the agricultural use of the land."

The use of "tiny homes", caravan park, tourism accommodation, or similar is not included in the zoning table of the FSLPS2. Therefore, Council may treat the proposal as a 'use' not listed:

"3.2.5 If the use of land for a particular purpose is not specifically mentioned in the Zoning Table and cannot reasonably be determined as falling within the interpretation of one of the use categories the Council may:

- a) Determine that the use is not consistent with the objectives and purposes of the particular zone and is therefore not permitted; or*
- b) Determine by absolute majority that the proposed use may be consistent with the objectives and purpose of the zone and therefore follow the advertising procedures of sub-clause 7.2 in considering an application for planning approval."*

Given that the proposal has a small footprint in comparison to the various lots of 443 Kilpatrick Road and that the proposal is to have only minor impacts on the main farming use of the land, it is recommended that Council support the application for the purposes of advertising.

Advertising Procedure

The advertising procedures are not located in sub-clause 7.2 as per the above quote. They are located in sub-clause 6.3 and are as follows:

“6.3.2 Where an application is made for planning approval to commence or carry out development which involves an "AA" use, or for any other development which requires the planning approval of the Council, the Council may give notice of the application in accordance with the provisions of this clause.

6.3.3 Where the Council is required or decides to give notice of an application for planning approval the Council shall cause one or more of the following to be carried out:

- a) notice of the proposed development to be served on the owners and occupiers of land within an area determined by the Council as likely to be affected by the granting of planning approval stating that submissions may be made to the Council within twenty-one days of the service of such notice;*
- b) notice of the proposed development to be published in a newspaper circulating in the Scheme Area stating that submissions may be made to the Council within twenty-one days from the publication thereof;*
- c) a sign or signs displaying notice of the proposed development to be erected in a conspicuous position on the land for a period of twenty-one days from the date of publication of the notice referred to in paragraph b) of this sub-clause.*

6.3.4 After expiration of twenty-one days from the serving of notice of the proposed development, the publication of notice or the erection of a sign or signs, whichever is the later, the Council shall consider and determine the application.”

Caravan Park and Camping Ground Regulations

Under the Caravan Park and Camping Ground Regulations 1997 (the Regulations), the proposed “Tiny Homes” are classed as “Caravans.” Schedule 7 of the Regulations outlines the criteria with which the “tiny homes” need to comply in order to be compliant caravans on a compliant caravan park. Written approval of the Local Government in accordance with Part 5 of the Regulations is necessary for the caravan park to operate in compliance with the Regulations. Any variations to the regulations including the proposed increase in maximum stay from three nights to four nights per 28 days requires written approval from the Minister for Local Government.

Bushfire Management Plan

Parts of 443 Kilpatrick Road are located in Bushfire Prone areas. The necessary Bushfire Attack Level Assessment has been completed and returned an attack level of BAL-29. As a result, a Bushfire Management Plan has been prepared and is included in Attachment 4. Any approval should further condition that a Bushfire Emergency Evacuation Plan be prepared.

Utilities

The proposed “tiny homes” are off-grid. Electricity is provided through the use of solar panels and batteries in each “tiny home”.

The Applicant proposes the use of waterless composting toilets from the Department of Health’s list of ‘Approved Waterless Toilets’.

Water tanks with a small capacity of 4,500 litres will be located at each “tiny home”. The reduced water capacity is mitigated by a maximum stay of 4 nights and overall maximum of 28 nights per 3 months for guests.

A shower, hand basin and kitchen sink are all included in each tiny homes. These will utilise water from the attached tanks. Waste water is to be processed using a settling tank and absorption style land application system.

The Wastewater Management proposal has been detailed in Attachment 3.

Traffic Management

All parking associated with the proposal will be contained on site. Each “tiny home” has a dedicated parking bay that will be 2WD accessible. Each internal road will be four metres wide gravel and include passing sections. The internal roads connect to existing crossovers.

Signage

Four timber signs all measuring 900mm wide and 400mm high on a one-metre-high post. These will be located at each driveway entrance. In order to address potential safety concerns, any approval should condition that the signs be a simple design and not located within the road reserve.

Vegetation

No clearing is necessary for establishing the “tiny homes” and associated infrastructure.

Management

Each “tiny home” will be managed by the two landowners residing on site. Cleaning and removal of solid waste is to be conducted by outside cleaners.

Disability Access

One “tiny home” is to be built as fully wheelchair accessible with a ramp included. Door width is compliant.

Tourism Strategy

The proposal directly relates to the Shire of Narrogin Tourism Strategy. The following information has been provided by the Manager Community, Leisure and Culture:

“Opportunities to stay on farms either in purpose-built cabins, bed and breakfast style, or simply through letting out a spare room on Airbnb is a low-risk way to increase the variety of appealing accommodation experiences. Offering supplemental tours and rural experiences, such as tractor rides, shearing demonstrations, fruit picking, animal feeding, etc., would further enhance the visitor experience. Although many of these experiences would not generate sufficient income to be viable as standalone tourism enterprises, they do offer opportunities for existing tourism businesses to value add, or for people employed in other industries to generate a supplemental income. The Shire’s role is primarily to highlight the opportunities and facilitate a clear regulatory path to ensure that barriers to providing enhanced tourism experiences in the Shire are not prohibitive.”

The proposed “tiny homes” address Strategy 4:

- *“Identify and cater for niche visitor interests*
- *Identify and develop tourist experiences that cater to specific niche interests (e.g., wildflowers, bird spotting, and nocturnal animal viewing, walk and mountain bike trails, (including the proposed pump track at Gnarojin Park).*

- *Take ownership of activities and interests of prospective visitors to the area and add them to Narrogin's tourism portfolio".*

The proposal also addresses the State's Two Year Tourism Action Plan and the State Government's 'Strategy for Tourism in Western Australia 2000'. This includes caravanning and nature-based experiences.

Voting Requirements

Part 1 of 2 – Absolute Majority

Part 2 of 2 – Simple Majority

OFFICERS' RECOMMENDATION – PART 1 OF 2

That, with respect to Application for Planning Consent: Tourism Accommodation (Use not listed) at Various Lots (No. 443) Kilpatrick Road, Nomans Lake, Council:

1. Determine that the proposed Use may be consistent with the objectives and purpose of the 'Farming' zone in accordance with Clause 3.2.5 b) of the Former Shire of Narrogin Local Planning Scheme No. 2
2. Publicly advertise the Application for a period of 21 days in accordance with Clause 6.3 of the Former Shire of Narrogin Local Planning Scheme No. 2

OFFICERS' RECOMMENDATION – PART 2 OF 2

That, with respect to Application for Planning Consent: Tourism Accommodation (Use not listed) at Various Lots (No. 443) Kilpatrick Road, Nomans Lake, if at the close of Public Advertising there are no negative submissions, Council approves the Application subject to the following conditions:

1. The approval shall expire if the development permitted is not completed within two years of approval, or within any extension of that time which, upon written application (made before or within 21 days after the expiry of the approval) to the Shire is granted by it in writing.
2. The development approved shall be in accordance with the plans and specifications submitted with the application and these shall not be altered or modified without the prior written approval of the Chief Executive Officer.
3. Any use, additions to and further intensification of any part of the development or land which is not in accordance with the original application or conditions of approval shall be subject to a further development application and consent for that use.
4. A Bushfire Emergency Evacuation Plan is to be prepared and submitted to the Shire prior to commencing operations on site.

Continued over page

5. Any advertising signage is not to be located on the road reserve and is to be simple and large font in order to be readable without causing driver inattention.

Advice Notes: Any variation to the maximum stay of 3 nights and any other variations to the provisions in the Caravan Parks and Camping Grounds Regulations 1997 shall not be allowed without the written approval from Minister for Local Government.



Planning Outcomes WA

town planning, urban design, landscaping + appeals

Our Ref: 443Kilpatrick-DA1

14 May 2021

Development & Regulatory Department
 Shire of Narrogin
 PO Box 1145
 NARROGIN WA 6312
 Via E-Mail: enquires@narrogin.wa.gov.au

Attn: David Johnston

Dear Sir,

VARIOUS LOTS, KILPATRICK ROAD, NOMANS LAKE – DEVELOPMENT APPLICATION PROPOSED CARAVAN PARK (5 x TINY CABINS) & SIGNAGE

Thank you for your e-mail regarding the above matter dated 29 January 2021.

Planning Outcomes WA has been engaged by the tenants (T/A Tiny Cabins) of the above property (the **Site** or **Subject Site**) to support a planning application for a caravan park (**Attachment 1**).

In response to the planning requirements, the following is submitted in support of the application, and structured as follows.

- | | |
|----------------------------------|------------------------------|
| 1. Background | 6. Land-Use |
| 2. Regional Context | 7. Site Requirements |
| 3. Local Context | 8. Access, Traffic & Parking |
| 4. Site Features & Existing Devt | 9. Planning for Bushfires |
| 5. Proposal Overview | 10. Other Potential Issues |

1. Background

In mid-2020, a cycling trail (Public Recreation use) was approved on the Site, used by the Wheatbelt Cycling Collective once every two months for events with between 2-20 people participating.

2. Regional Context

The Subject Site is located 230 kilometres southeast from Perth (by road) in the Wheatbelt Region, 205km east from Bunbury, and 32km east from Narrogin, in the rural locality of Nomans Lake (**Attachment 4.1**).

3. Local Context

The Site is zoned Farming under the Shire’s Local Planning Scheme No. 2 (**Scheme**), in a locality with a rural character, noting the following within the focus area.

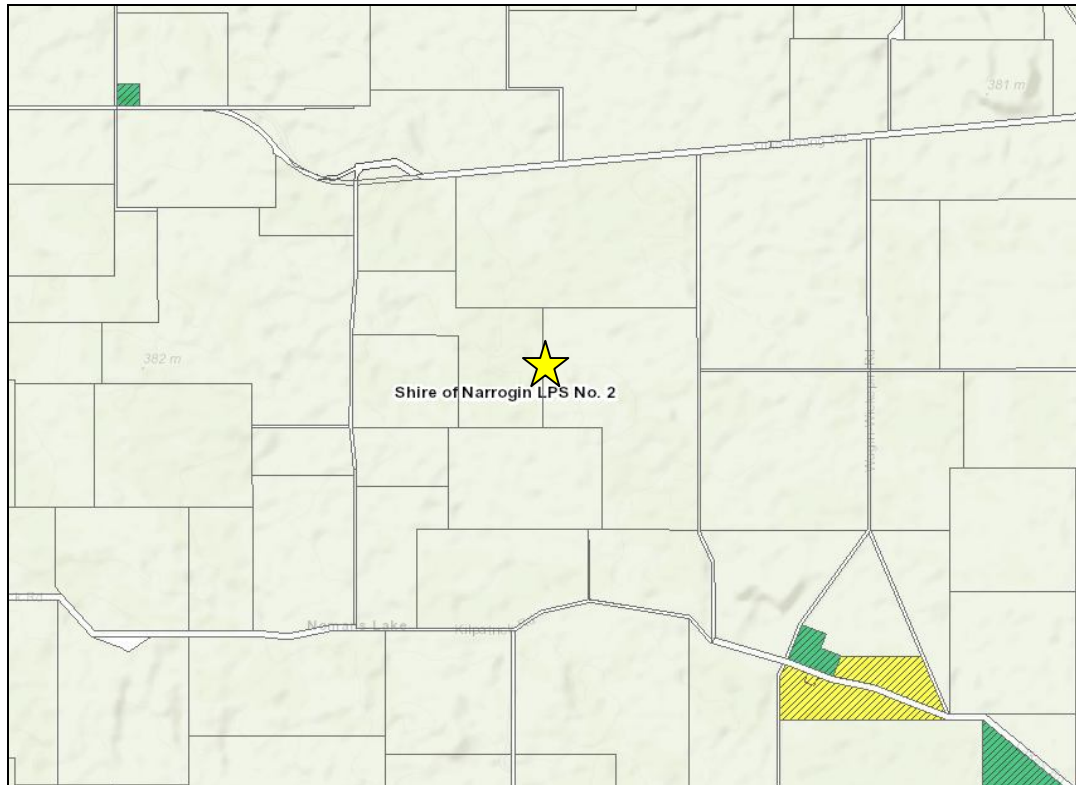

Scheme Zones & Reserves

Local Zoning within the Focus Area		
Direction	Zoning	Current Land-Use
North	opposite a <u>Farming</u> zone	Agricultural
East	opposite a <u>Farming</u> zone	Agricultural
	opposite a <u>Parks & Recreation</u> reserve	Unknown building, all possibly vacant
	opposite a <u>Public Purpose</u> reserve	
South	opposite a <u>Farming</u> zone	Agricultural
West	abuts a <u>Farming</u> zone	Linda Valley Farm (sheep and cropping) <u>Bed & Breakfast</u>

4. Site Features & Existing Development

The Subject Site currently features the following:

- **Roads** – Located on Kilpatrick, Yillmilling and Wagin-Wickepin Roads within the rural locality of Nomans Lake, with all but Kilpatrick being sealed.

- **Large Landholding** – The Site has a large area of approximately 1,600 hectares, large enough to facilitate existing farming and the proposal without significantly impacting neighbouring properties. The Site is divided into many smaller lots (**Attachment 4.2**) for historical reasons, but with the same owners.
- **Topography** – Ground levels are sloping with a slight average grade (70m from east to west over a distance of 4.8km).
- **Existing Development** – Includes broadacre cropping, a homestead, various sheds, many dams, and water tanks.
- **Encumbrances on the Title** – Nil (Landgate search).

Subject Site by Lot			
Address	Vol./Fol.	Area	Landowners
No. 443 (multi lot) Kilpatrick Road, Nomans Lake		see below	
Lot 5324		652,865m ²	
Lot 6645		647,927m ²	
Lot 6801		2,321,106m ²	Joseph & Meryl <u>Armstrong</u>
Lot 7056 (No. 363)	1705/523	644,757m ²	
Lot 10463		419,094m ²	
Lot 10634		411,882m ²	
Lot 11485		1,047,905m ²	
Lot 3888	2652/350	809,096m ²	
Lot 5092	1934/743	824,930m ²	Joseph & Meryl <u>Armstrong</u>
Lot 7186 (part)	1705/524	1,069,081m ²	
Lot 10845 (part)	1302/478	3,649,471m ²	
Lot 3	2659/390	214,232m ²	
Lot 4	2659/391	369,448m ²	
Lot 9856	1548/436	2,027,072m ²	<u>Armstrong</u> Farmlands Pty Ltd
Lot 10717	2652/357	1,418,618m ²	
Lot 14845 (part)	1238/605	550,625m ²	
Total		17,078,109m²	(4,220 ac. / 1,708 ha.)



Subject Site – Farmlands

5. Proposal Overview

The proposed development is considered to be low-impact with the following features (**Attachments 4.3-4.4**):

- **Theme** – Working farm with onsite mountain bike trails.
- **Accommodation** – 5 x tiny homes / tiny cabins / caravans, 2.9m x 7.0m (20m² each).
- **Services & Amenities** – Gas, power, water supply, hot water, shower, toilet, air-conditioning, kitchenette and laundry facility.
- **Deck & Stairs** – Freestanding structure, removable, for access only (3m²).



Tiny Cabin – Chittering Site

- **Car-Parking** – Ample parking.
- **Access** – Unsealed driveways (2WD), proposed footpaths.
- **Signage** – Simple pylon signs, site-specific advertising.
- **Existing Vegetation** – No clearing required.
- **Visual Impact** – Large site, tiny cabin, earthy tones.
- **Guests** – Max. 2 persons per unit (8 total), adults only, no animals except for assistance dogs.
- **Operations** – 24 hours per day, 7 days a week, 16 month year lease with possible extension.

Operational details are as follows, and considered low-impact:

- **Duration of Stay** – Typically 2 nights, max. 4 nights (compliant to max. 28 days / 3 months).
- **Management / Staffing** – 2 staff (the landowners) residing onsite plus 1-2 external cleaners.
- **Tracks** – Driveways min. 4.0m wide with passing opportunities throughout.
- **Disabled Access** – Plans show a compliant large door, and a disabled access ramp will be provided for one cabin.
- **Laundry Facility** – An internal wash-basin and space for a caravan washing machine (ultra compact) is included in the utility room.
- **Phone & Internet** – 3G Telstra and Optus is available except on the lower plain.



Daybed



Kitchen, Toilet & Main Bed Above

- **Power** – Solar panels on roof.
- **Water Supply** – 1,000L internal tank and 4,500L external tank.
- **Wastewater** – Settling tank and absorption trench system (**Attachment 3**).
- **Solid Waste** – Removed by cleaners.



Roof-Mounted Solar Panels

6. Land-Use

The Scheme Zoning Table does not have an extensive list of land-uses, and does not provide guidance on this proposal, which necessitates the employment of a Use Not Listed.

Being DoT-registered caravans (number-plated), the proposal can be considered to meet the Scheme definition of 'Caravan Park':

means an area of land specifically set aside for the parking of caravans and park homes or for the erection of camps on bays or tent sites allocated for that purpose.

As the proposed use is not listed, an analysis of the zone objective is considered below and found to be compliant.

Farming Zone – Objectives (s. 4.13)		
Objectives	Response	Complies?
The Council intends the predominant form of farming activity in the Farming Zone will continue to be based on large farming units.	The Site is currently used for broad-acre cropping, and will continue so.	Yes
4.13.2 Development: The Council shall not grant planning approval for any development that will in the opinion of the Council adversely affect the rural landscape or be contrary to the agricultural use of the land.	Being small cabins, they are low-impact, 'touching the ground lightly', earthy colours, and fitting well within the rural landscape.	

Caravan Reg's

Examining the requirements in the *Caravan Parks and Camping Grounds Regulations 1997* Schedule 7, it is apparent that the proposal complies:

- **Park Types** – Nature-Based Parks with a presumption against most ancillary structures.
- **Management** – Must be onsite.
- **Duration of Stay** – Max. 28 days / 3 months.
- **Setbacks** – 3.0m between caravans/camps, 1.0m to boundaries.
- **Services** – Must be provided.
- **Fencing** – Limits on specifications.
- **Roads** – Min. 4.0m wide, with passing opportunities throughout, speed limit (8km/h).
- **Mobility** – Caravans able to be moved within 24 hours.
- **Licensing** – Further licence required after planning approval.

7. Site Requirements

Relevant site requirements of the Scheme have been considered below, and the proposal is found to be compliant.

Site Requirements (Cl. 4.5)				
Issue		Required	Proposed	Complies?
Building Setbacks	Northern Cabin	20m	37m	Yes
	Northwest Cabin		44m	Yes
	Western Cabin		135-139m	Yes
	Southern Cabin		127m	Yes
	Eastern Cabin		88m	Yes
NB: None of the roads are controlled by Main Roads.				

8. Access, Traffic & Parking

Access

Access is gained from Kilpatrick (Access Road), Yillmilling (Regional Distributor) and Wagin-Wickepin Roads (Local Distributor), with all but Kilpatrick being sealed. None of the roads are controlled by Main Roads. Driveways are not proposed to be sealed in keeping with the rural character of the locality.

Traffic

With regard to traffic, proposed vehicle movements is 4 trips in peak hour, is classed as 'low impact' as it is under the threshold of 10 trips, and therefore a transport statement or assessment is not required in accordance with the Transport Impact Assessment Guidelines 2016.

Parking

Specific car-parking requirements are not found in the Scheme or the Policy Manual. Notwithstanding this, each cabin will be provided with a suitable field parking area, and are not proposed to be sealed in keeping with the rural character of the locality.

9. Planning for Bushfires

As the Site is within a Bushfire Prone Area (**BPA**), a Bushfire Attack Level (**BAL**) assessment Bushfire Management Plan (**BMP**) was commissioned and returned a BAL-29 rating (**Attachment 2**), which does not present any barriers to development. Furthermore the site also has two access routes for safe access and egress.

10. Other Potential Issues

The Site is not listed as a Bush Forever site or a Heritage site (local / state / aboriginal).

In relation to neighbour consultation, it is anticipated that the minimal impact of the structures will not generate objections.

With regard to the application fee, a call or invoice from the cashier is requested.

Conclusion

This application is for a 5 low-impact tiny homes (caravans) on a large property with an existing farm. The Site is well-placed for tourist accommodation, with the locality having a strong rural character with one neighbouring property also operating tourist accommodation (a B&B). The property also has a working farm theme and onsite mountain-bike trails. All these activities will work well together to bolster each other and the wider local economy.

The units are fitted-out with ample services for comfort and enjoyment. The development is minimalistic, low-intensity and low-impact with no clearing required and touching the ground lightly. The proposal is compliant with local and state requirements, not least of which is the Bushfire Guidelines.

Accordingly, it is considered that the proposed development is an acceptable outcome for the Site and the surrounding area, and as such the Shire's discretion is requested to approve the discretionary land-use. If the Shire does not see this proposal as being acceptable, I would appreciate a call or meeting to discuss the most efficient way forward.

If you have any queries, or wish to discuss this matter further, please do not hesitate to contact me.

Yours sincerely



Matt Stuart

Principal Urban Planning Consultant

BA (URP) Hons | Grad Cert (UD) | MLGPA

0408 000 477 | matt@townplanningadvice.com.au

- Att.
1. Development Application Form (dated 24 February 2021)
 2. BMP & Certificate (dated 4 May 2021)
 3. Wastewater Management Plan (dated February 2021)
 4. Development Drawings (Rev. A)



Planning Outcomes WA M: 0408 000 477
 W: www.townplanningadvice.com.au
 town planning, urban design, landscaping + appeals

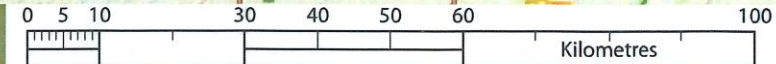

© Copyright protects this plan.
 Unauthorised reproduction or
 amendment not permitted.

Various Lots, Kilpatrick/Yillmilling/Wagin-Wickepin Roads, Nomans Lake
 Tourism Development - Att. 4.1: Regional Plan

Rev. A - May 2021
 Tiny Cabins
 1:1M (A4)

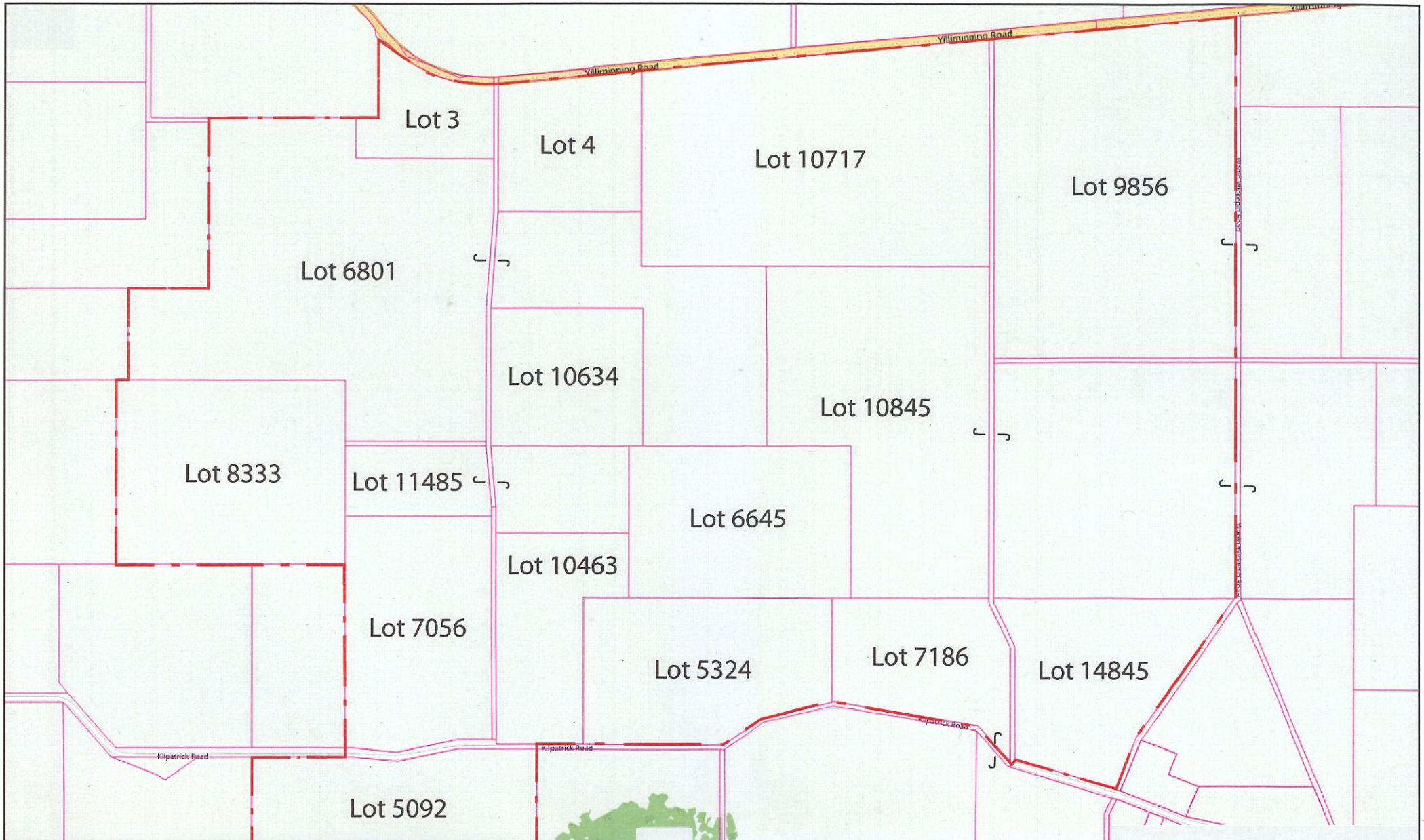

No Restrictive Covenants, Caveats, or Easements for the Subject Site.



LEGEND (Not To Scale)	
	Gate, min. 3600W
	Signage
	2WD Driveway, 4000W (compacted gravel / limestone / sealed)
	Emergency & Service, 4000W
	Bike Trail (existing)
	Carpark, gravel
	Tiny-Cabin, 2.9m x 7.0m
	Dam (existing)
	Water Tanks
	Firefighting Equip. (existing)
	Setback to Boundary

SIGNAGE

1:100

Timber Sign

Pylon Sign Elevation (North)

- 900H x 400W (0.36m²)
- Non-illuminated
- Not overhanging verge

APPROVAL

Planning Outcomes WA M: 0408 000 477 W: www.townplanningadvice.com.au
town planning, urban design, landscaping + appeals
Shire of Narrogin

© Copyright protects this plan. Unauthorised reproduction or amendment not permitted.

TINY CABINS

0 100 300 600 1000 Metres

Rev. A - May 2021
Tiny Cabins

Various Lots, Kilpatrick/Yillmilling/Wagin-Wickepin Roads, Nomans Lake

Tourism Development - Att. 4.3: Site Plan 1:15,000(A3)

Page | 27

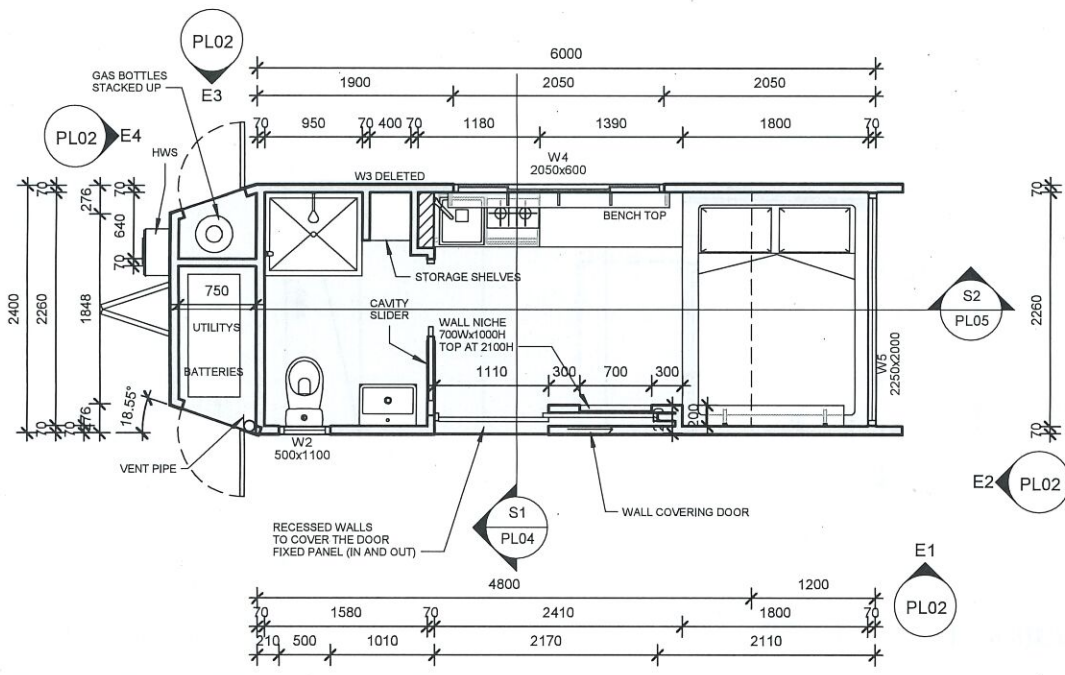

① Floor Plan - TINY HOUSE - 1 : 50

REVISIONS 29.09.2020 - REVISIONS			
PROJECT:	Proposed Tiny House 2 TINY CABINS		
CLIENT:	PERTH WESTERN AUSTRALIA		
DRN:	SCALE	DATE:	DRAWING NO.
P.S.	1 : 50	29.09.2020	
FLOORPLAN			SK1 PL01

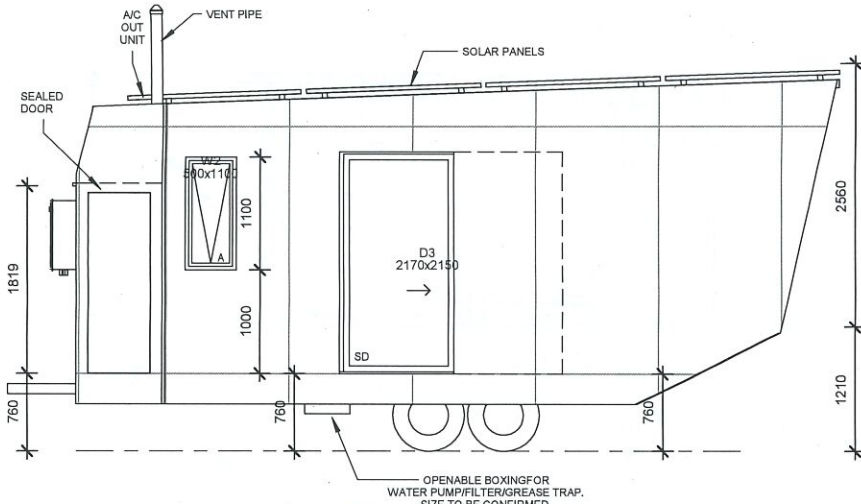

E1 Elevation 1 - 1 : 50

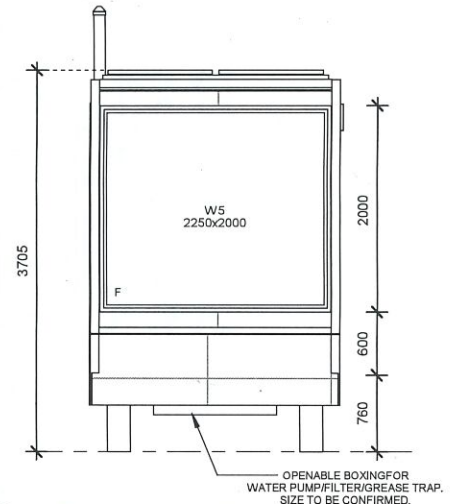

E2 Elevation 2 - 1 : 50

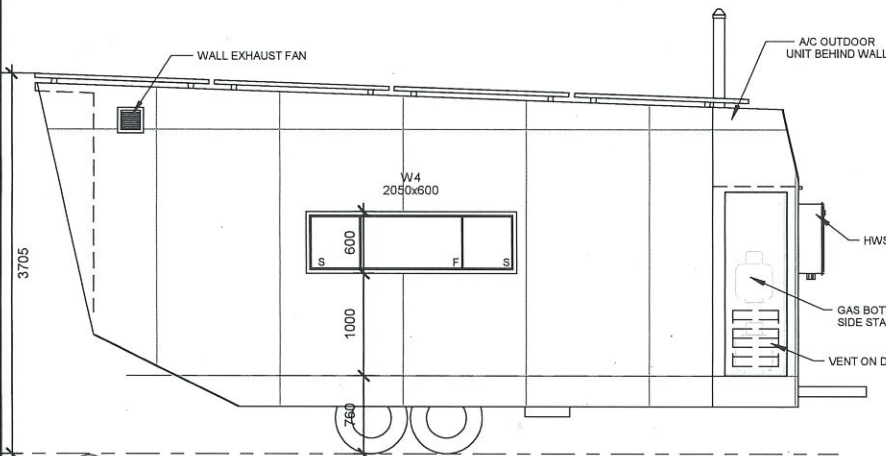

E3 Elevation 3 - 1 : 50

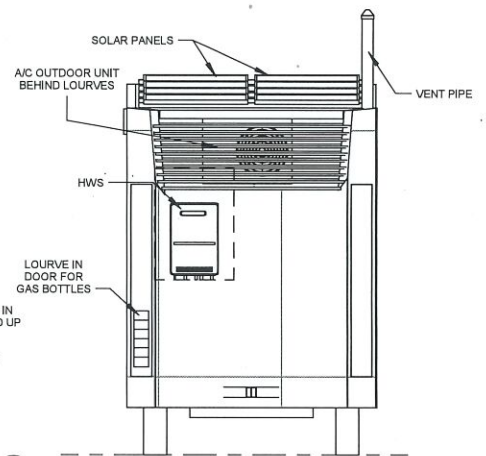

E4 Elevation 4 - 1 : 50

REVISIONS 29.09.2020 - REVISIONS

PROJECT:	Proposed Tiny House 2 TINY CABINS		
CLIENT:	PERTH WESTERN AUSTRALIA		
DRN:	SCALE	DATE:	DRAWING NO.
P.S.	1 : 50	29.09.2020	
Elevations			SK1 PL02

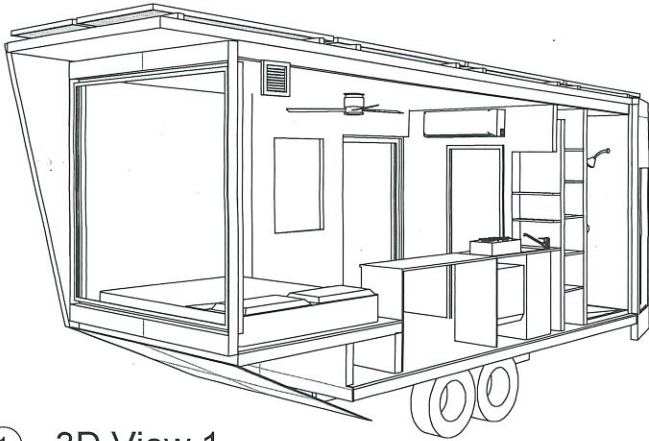

① 3D View 1 -

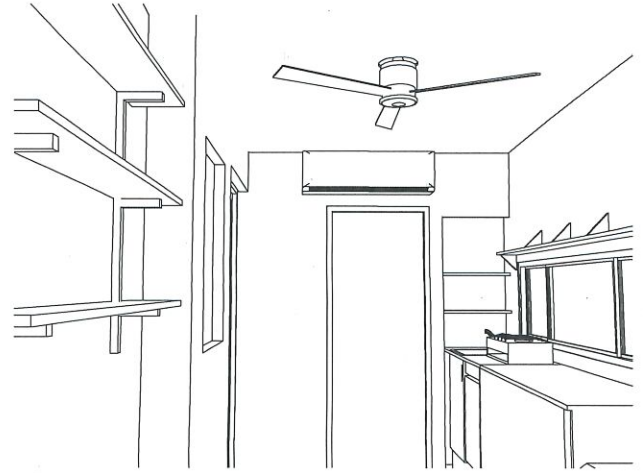

② 3D View 2 -

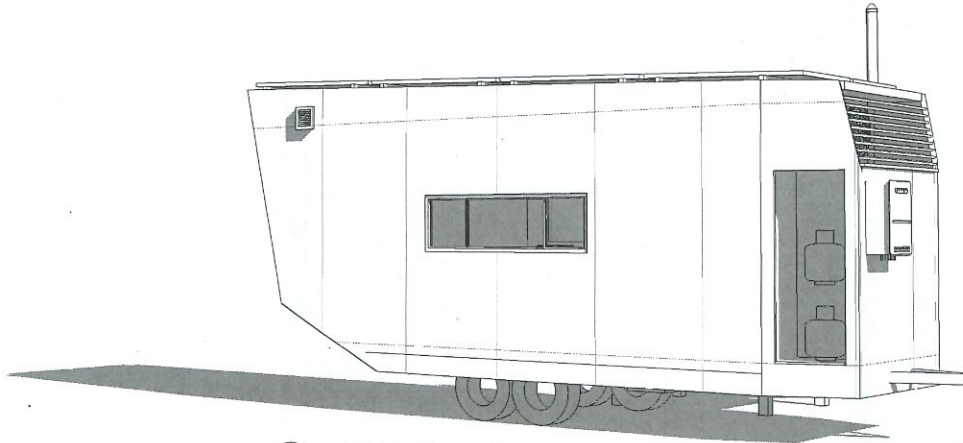

③ 3D View 3 -

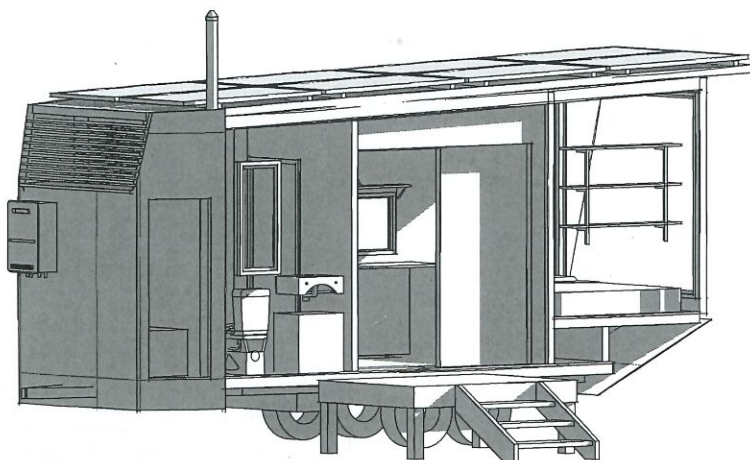

④ 3D View - Isometric -

REVISIONS 29.09.2020 - REVISIONS

PROJECT:		Proposed Tiny House 2	
CLIENT:		TINY CABINS	
		PERTH	
		WESTERN AUSTRALIA	
DRN:	SCALE	DATE:	DRAWING NO.
P.S.		29.09.2020	
3D VIEWS			SK1 PL03

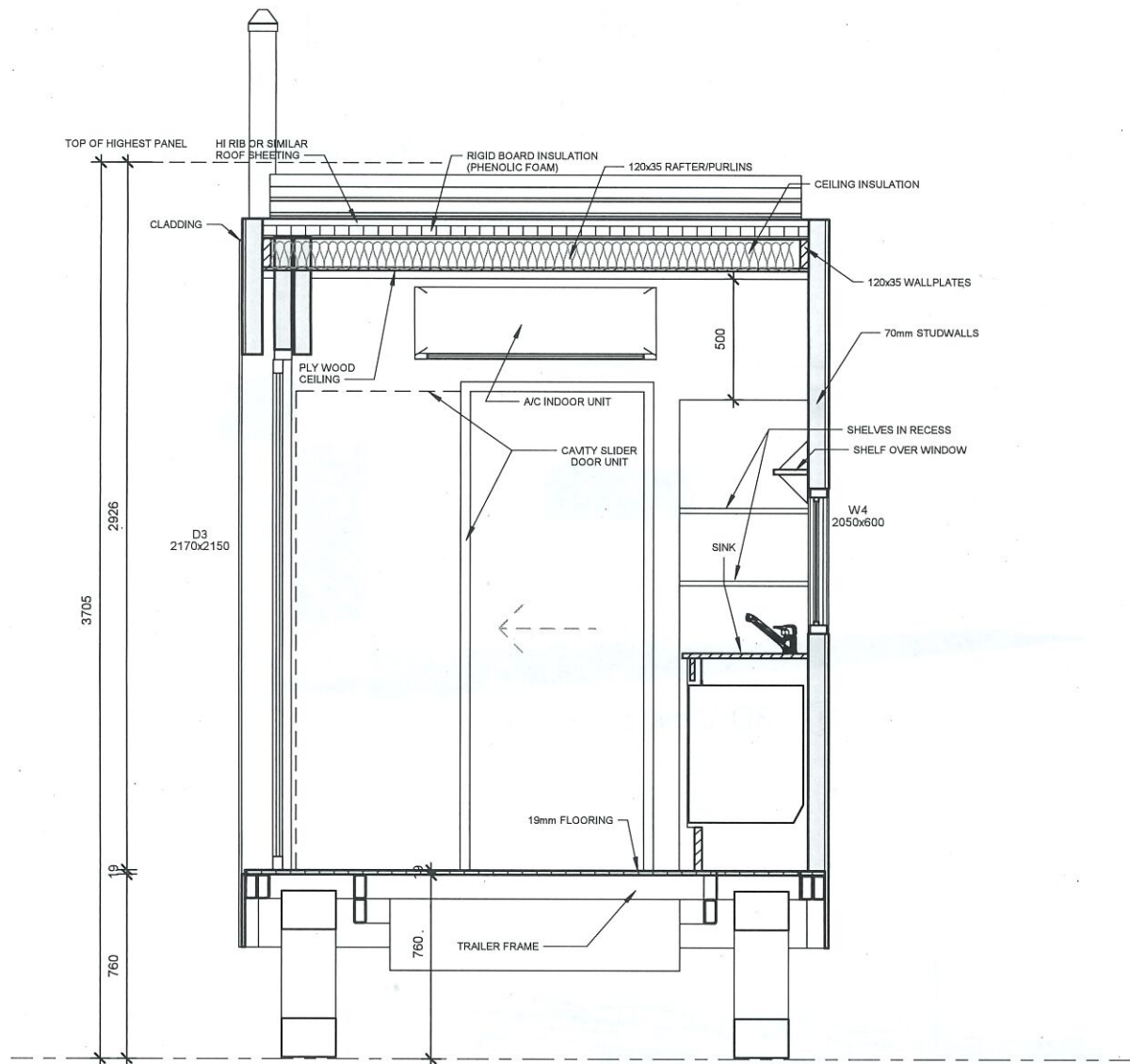

(S1) Section 1 - 1 : 20

REVISIONS 29.09.2020 - REVISIONS

PROJECT:	Proposed Tiny House 2 TINY CABINS		
CLIENT:	PERTH WESTERN AUSTRALIA		
DRN:	SCALE	DATE:	DRAWING NO.
P.S.	1 : 20	29.09.2020	
Sections			SK1 PL04

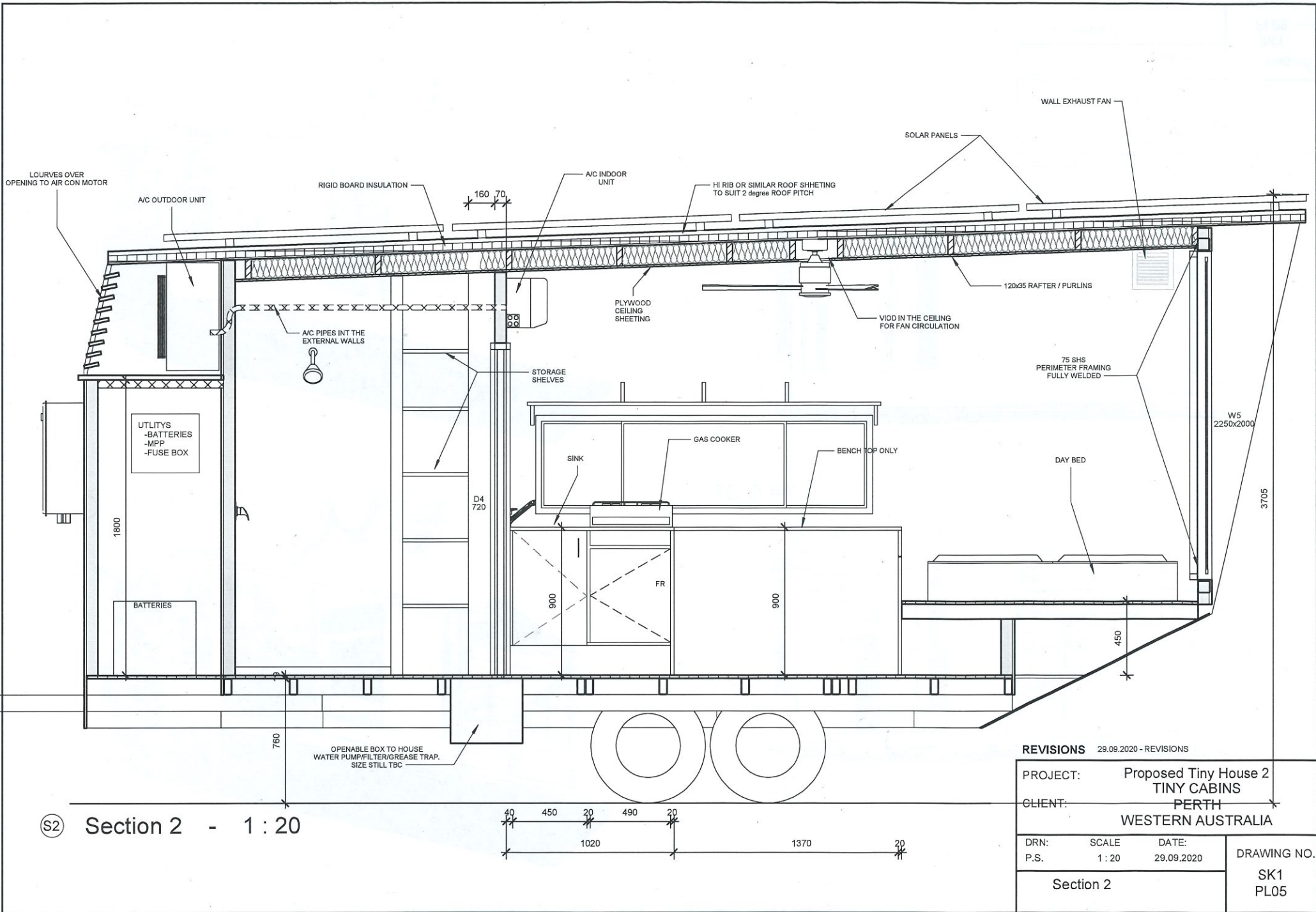

REVISIONS 29.09.2020 - REVISIONS			
PROJECT:		Proposed Tiny House 2 TINY CABINS	
CLIENT:		PERTH WESTERN AUSTRALIA	
DRN:	SCALE:	DATE:	DRAWING NO.
P.S.	1:20	29.09.2020	
Section 2			SK1 PL05

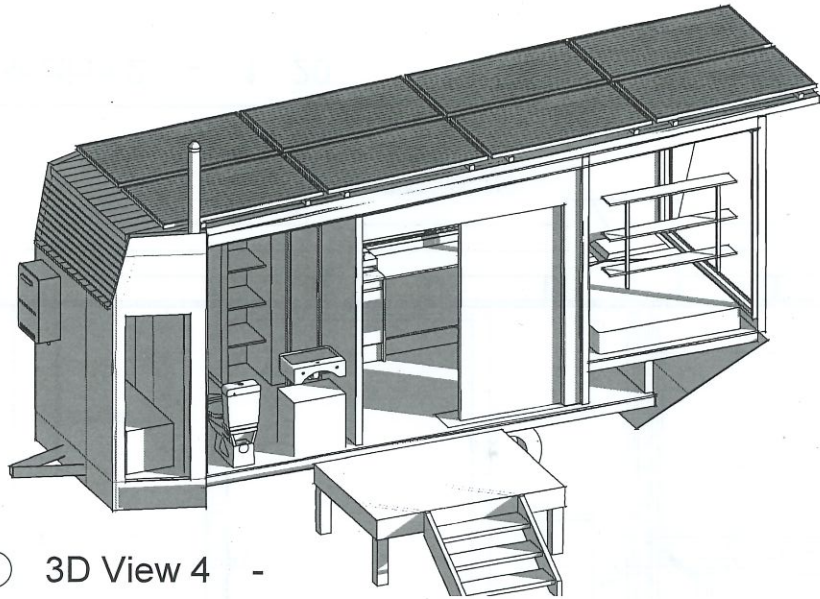

① 3D View 4 -

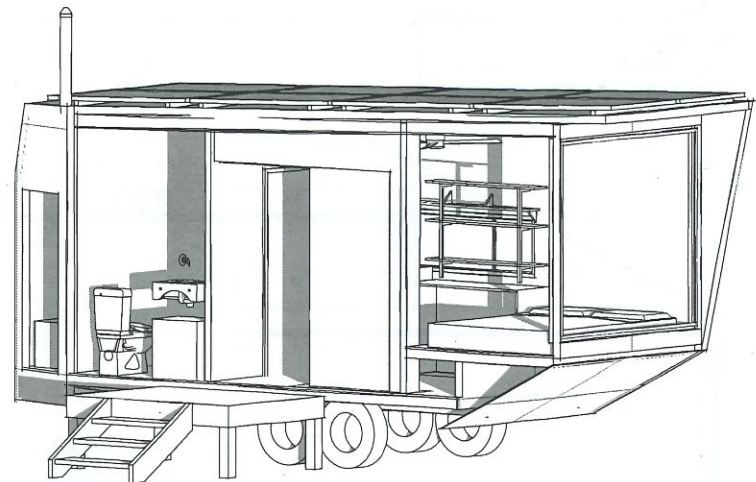

② 3D View 5 -

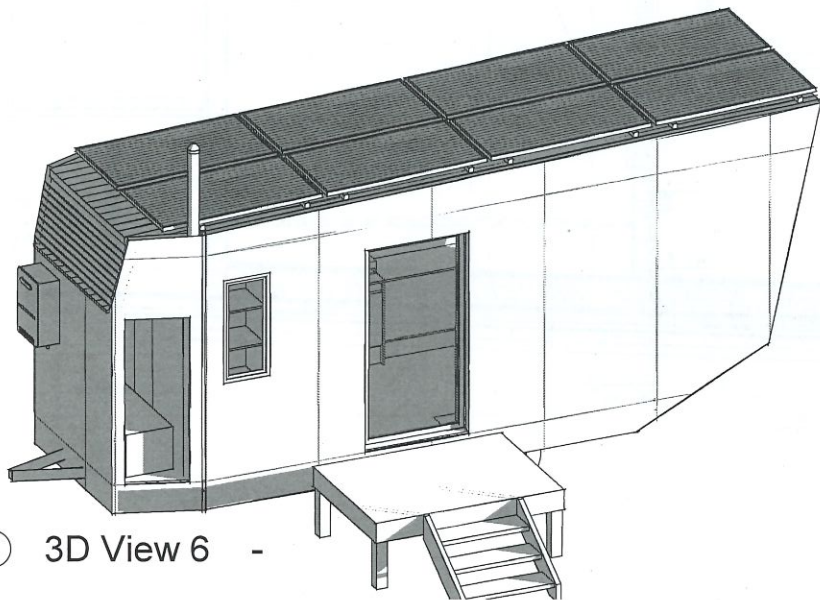

③ 3D View 6 -

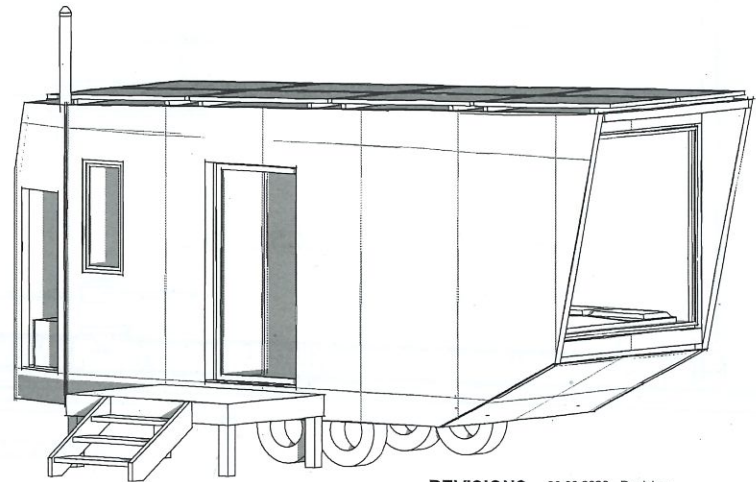

④ 3D View 7 -

REVISIONS 29.09.2020 - Revisions			
PROJECT:		Proposed Tiny House 2	
		TINY CABINS	
CLIENT:		PERTH	
		WESTERN AUSTRALIA	
DRN:	SCALE	DATE:	DRAWING NO.
P.S.		29.09.2020	
3D Views 2			SK1 PL06



ECO WASTEWATER
SOLUTIONS

**WASTEWATER
MANAGEMENT SYSTEM
DESIGN PROPOSAL**

443 Kilpatrick Road, Normans Lake, WA

Prepared for: Sam Soley – Tiny Cabins
February 2021

Anthony Smith
info@ecowastewater.com.au
Ph: (08) 9758 8640 Mob: 0407 247 844
10 Merchant Street, Margaret River, W.A.
www.ecowastewater.com.au

Contents

Introduction.....	2
Background and Development Description	2
Fixtures and water consumption / hydraulic loading.....	5
Water Supply	5
Fixtures	5
Hydraulic loading	5
Low impact, sustainable tourism	5
Relevant excerpts from the “House Rules”	5
Mindful Solar and Water Consumption	5
Kitchenette and Washing Dishes.....	5
Toilets	6
Greywater	6
Grease Trap.....	6
Sedimentation/Settling Tank	7
Piped Trench/Bed System	7
Maintenance and reporting	8

Introduction

This document has been prepared to describe and support an Onsite Wastewater Management Application for the above property. The application is to be considered as a special case. The proposed development and usage of proposed facilities is considerably different from standard usages and hence the proposed system design may fall outside of current regulations. Suitable design considerations with reference to relevant documentation has been made to support the feasibility of the design and its appropriateness as a wastewater management solution for this proposed development.

To support the design sizing and components of this unconventional style of development, a prototype setup has been built and operational on a private property in Chittering. This prototype setup, referred to as 'Joey', has been able to provide valuable data including actual water usage, wastewater production volumes and physical, proven evidence that this small-scale wastewater management system is effective and sustainable.

Background and Development Description

The proposed development consists of small self-contained holiday cabins.



Figure 1: Front view of the tiny cabin "Joey" in Chittering.

The cabins are energy and water efficient, holiday accommodation alternatives. They have a small ecological footprint and the wastewater management system, consisting of a waterless composting toilet and small-scale greywater dispersal system, has a minimal/negligible impact on the environment.

There is a maximum of 2 guests allowed per booking and a standard booking duration of 2 nights (representing most bookings).



Figure 2: Inside view of “Joey” showing the tiny kitchen on the right.

Maintenance is performed at the cabins on a regular basis in between bookings or during periods of vacancy. Cleaners are tasked with the upkeep of the cabins in between bookings and perform a review of the cabins’ facilities at every checkout.

Figure 3: Site plan and proposed cabin locations:

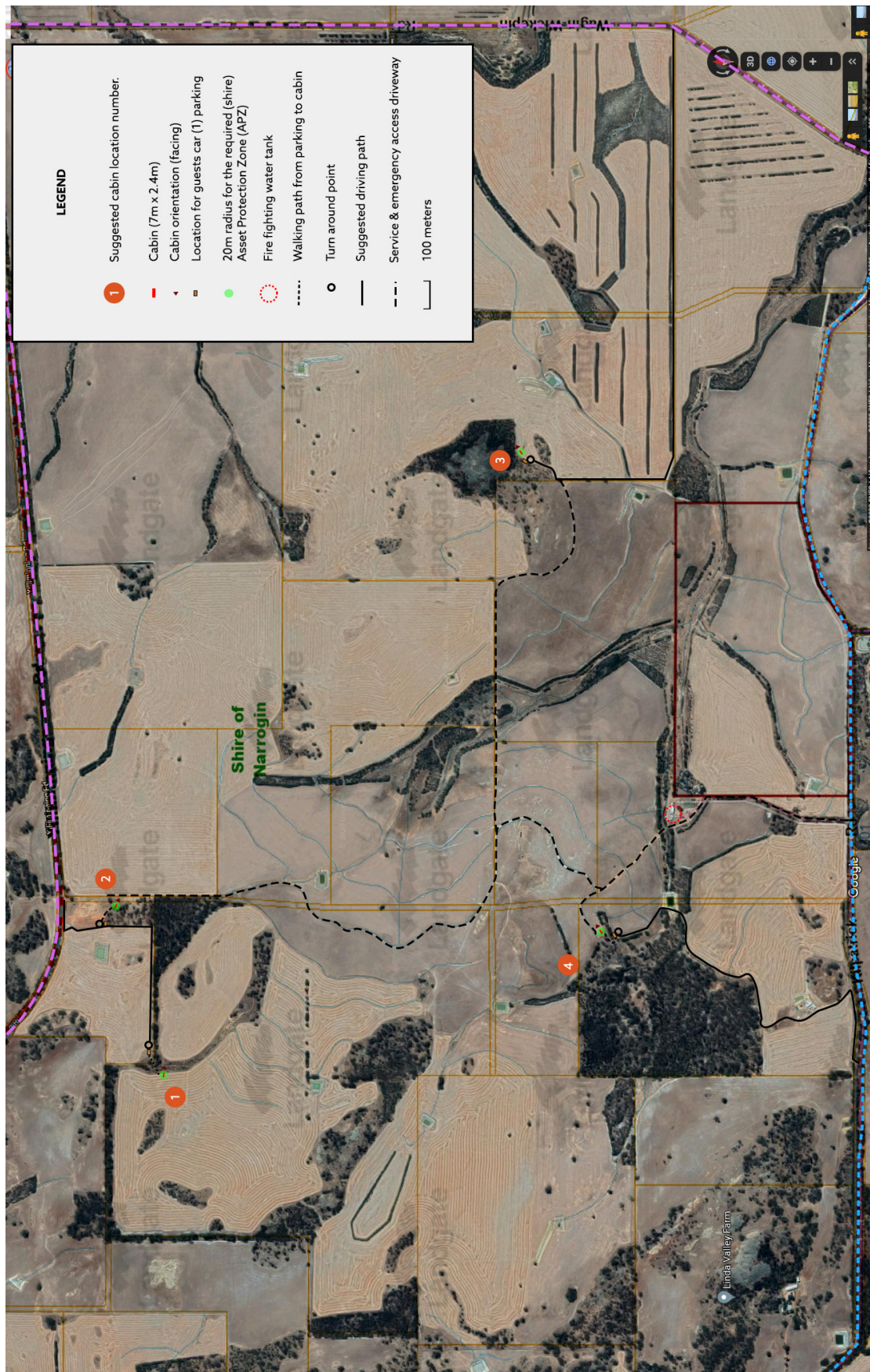

Fixtures and water consumption / hydraulic loading

Water Supply

A 4,500L potable water premium corrugated tank is the sole water supply. It is suitable for drinking water in accordance with AS/NZS 4020:2002 and AS 2070 Part 1 & Part 8 Aust. Std. for food contact.

Fixtures

Each cabin will have:

- 1 x waterless toilet
- 1 x hand basin
- 1 x shower
- 1 x small kitchen sink

Note: no laundry facility

All taps are manufactured to comply with a WELS rating of 4 stars or more (7.5L/min or less) in accordance with AS/NZS 6400:2005.

Hydraulic loading

- No wastewater is produced from the waterless toilet. A small, excess liquid drain will be installed, as per manufactures specifications.
- Actual wastewater production volumes have been recorded over a 12-month period from the prototype setup, 'Joey'. The maximum combined wastewater production volume from shower, handbasin and kitchen use, over this 12-month period (2019 – 2020) was **18L/p/d.**
- The nominated design hydraulic loading for this proposed development is **40L/p/d.** - incorporating more than a 2X design safety buffer.
- Max occupancy of two guests per day, total maximum design hydraulic loading $40 \times 2 =$ **80L/d.**

Low impact, sustainable tourism

Cabin guests are encouraged to embrace a minimalist lifestyle during their stay to minimise environmental impacts and promote sustainable tourism.

Guests are provided with biodegradable soaps and detergents and the "House Rules" are both emailed out to guests before their bookings and confirmed on laminated sheets mounted on the cabin wall and in the cabin booklet.

Relevant excerpts from the "House Rules"

Mindful Solar and Water Consumption

"The Cabin is not connected to mains water or power. We have solar power which will charge the batteries during the day and water is either rainwater or water delivered.

Please be mindful about the amount of water and power you use. Please don't leave taps running unnecessarily and please turn off all appliances when you leave the cabin."

Kitchenette and Washing Dishes

"The cabin has a small sink in the kitchenette. As the water from the kitchen sink is filtered and processed it is important to make sure that NO food scraps, fats or oils are washed down the sink. This greatly helps the performances of our greywater system and reduces the need for maintenance."

“Before washing any dishes and cutlery, please wipe all excess food scraps and oils/fats using the paper towels provided (in the cupboard) and dispose of the paper towels in the rubbish bin. Once plates and cutlery have been wiped you can wash your dishes with the biodegradable dishwashing liquid provided. Wiping your dishes first will also help you conserve water!”

Toilets

There are several composting toilet models, approved by the WA Department of Health, which would be suitable for this application. Specifically, one Green Loo - GL90 will be installed in each cabin. This model is on the W.A. Department of Health’s list of ‘Approved Waterless Toilets’ and is approved to the capacity of 3 people, full time usage. This model is suitable, and would have ample capacity, for the proposed usage.

Guests of the cabins are informed on how to use the toilet with a wall note in the toilet area, multiple notes in the cabins booklet and digital information sent at the time of booking and prior to the guest’s arrival in the cabin.

Excerpt from the cabin’s booklet, “house rules”:

“Our composting toilet operates very much like your toilet at home with the only difference that it is dry. The only things supposed to go down the composting toilet are your solids and liquids accompanied by our provided toilet paper.”

The toilet will be installed according to the manufacturer requirements.

In compliance with Health Dept. regulations and guidance from AS/NZS 1546.2:2008 – *On-site domestic wastewater treatment units – Waterless Composting Toilets*, the composted end-product from the toilet will be buried on site away from human contact and in non-food related plant areas.

Greywater

Greywater from all sources (shower, handbasin and kitchenette), will be managed with a simple, passive settling and absorption style land application system. The design of this system is based on design principles taken from Australian Standards AS/NZS 1547:2012, scaled down to accommodate the small wastewater volumes from the cabins.

Kitchen water will pass through a small grease trap to capture grease, oils, fats and food scraps upstream of the main sedimentation/settling tank. This will allow ease of access and maintenance/disposal of captured solids wastes (greases and food scraps etc). Partially clarified water will flow from the grease trap into the main sedimentation/settling tank.

Greywater from the shower and handbasin will flow directly into the main sedimentation/settling tank combined with the partially clarified water from the kitchenette grease trap.

Clarified greywater will then flow from the sedimentation/settling tank into a simple land application absorption trench in accordance with AS/NZS 1547:2012.

Grease Trap

Although the guests are encouraged to minimise grease, fat, oil and food scraps going down the kitchen sink (see excerpt from “House Rules”), the installation of a small grease trap will reduce the organic loading of the sedimentation tank and piped trench system as well as making maintenance of the system manageable by staff.

Assuming kitchen water production of 15L day, a grease trap of 15L/d capacity or larger will give retention time of at least 1 day and hence will allow the grease trap to perform effectively.

Nominated Grease Trap: Reln 18L



Sedimentation/Settling Tank

A tank of 200L capacity will enable a retention time of 2.5 days, similar to the design capacity of septic tanks (200 / 80 = 2.5).

Nominated Tank: AWWS 200L Settling tank.

Piped Trench/Bed System

Utilising design principles from AS/NZS 1547:2012 and with reference to the Grey to Green system (W.A. Department of Health 'approved greywater disposal system'), the greywater disposal Land Application Area will consist of:

Assuming (worst case scenario) **Clay loam: L.I.R 15 L/m²/day**, (Health (Treatment of Sewage and Disposal of Effluent and Liquid Waste) Regulations 1974).

Length of bed required:

$$L = (V / \text{L.I.R.}) / 2$$

Where L = Length of bed (m), V= design flow volume (L/day) and L.I.R. = Loading Infiltration Rate (L/m²/day)

$$L = (80/15) / 2 = \underline{2.6\text{m}}$$

Greywater absorption bed dimensions: **2 width x 3m length.**

Installation

The greywater disposal system will be assembled and installed in accordance with AS/NZS1547:2012 and/or the approved product design and sizing document for the Grey 2 Green System as specified by the Department of Health.

The conventional piped trench will be clear of all rocks, tree roots and debris to the depth of the drain bottom and to comply with all setbacks as specified relevant regulatory documentation. Stormwater will be diverted away from the piped trench area.

Maintenance and reporting

The installation will be inspected by Eco Wastewater Solutions 3 months after its installation to ensure its efficacy and efficiency. Similarly, after 12 months, a report will be prepared by Eco Wastewater Solutions and submitted to the local government, or any other relevant regulatory authority, indicating the efficacy and efficiency of the system.

Maintenance will be carried out by Eco Wastewater Solutions at a maximum interval of 12 months or ad hoc as the conditions dictate.



Fire Protection
Association Australia
Life. Property. Environment.



Bushfire Management Plan Coversheet

This Coversheet and accompanying Bushfire Management Plan has been prepared and issued by a person accredited by Fire Protection Association Australia under the Bushfire Planning and Design (BPAD) Accreditation Scheme.

Bushfire Management Plan and Site Details

Site Address / Plan Reference: 443 Kilpatrick Road			
Suburb: NOMANS LAKE	State: WA	P/code: 6312	
Local government area: Shire of Narrogin			
Description of the planning proposal: Tourism Land Use - Tiny Cabins			
BMP Plan / Reference Number: 201008	Version: v1.0	Date of Issue: 04/03/2021	
Client / Business Name: Proponent - Heyscape Pty Ltd & Planning Outcomes WA			

Reason for referral to DFES	Yes	No
Has the BAL been calculated by a method other than method 1 as outlined in AS3959 (tick no if AS3959 method 1 has been used to calculate the BAL)?	<input type="checkbox"/>	<input checked="" type="checkbox"/>
Have any of the bushfire protection criteria elements been addressed through the use of a performance principle (tick no if only acceptable solutions have been used to address all of the BPC elements)?	<input type="checkbox"/>	<input checked="" type="checkbox"/>
Is the proposal any of the following special development types (see SPP 3.7 for definitions)?		
Unavoidable development (in BAL-40 or BAL-FZ)	<input type="checkbox"/>	<input checked="" type="checkbox"/>
Strategic planning proposal (including rezoning applications)	<input type="checkbox"/>	<input checked="" type="checkbox"/>
Minor development (in BAL-40 or BAL-FZ)	<input type="checkbox"/>	<input checked="" type="checkbox"/>
High risk land-use	<input type="checkbox"/>	<input checked="" type="checkbox"/>
Vulnerable land-use	<input checked="" type="checkbox"/>	<input type="checkbox"/>

If the development is a special development type as listed above, explain why the proposal is considered to be one of the above listed classifications (E.g. considered vulnerable land-use as the development is for accommodation of the elderly, etc.)?

Tourism Land Use - Short stay accommodation or visitation uses that involve people who are unaware of their surroundings and who may require assistance or direction in the event of a bushfire.

Note: The decision maker (e.g. local government or the WAPC) should only refer the proposal to DFES for comment if one (or more) of the above answers are ticked "Yes".

BPAD Accredited Practitioner Details and Declaration

Name Kathy Nastov	Accreditation Level Level 3	Accreditation No. BPAD 27794	Accreditation Expiry 01/08/2021
Company Bushfire Prone Planning		Contact No. 6477 1144	

I declare that the information provided within this bushfire management plan is to the best of my knowledge true and correct

Signature of Practitioner

Date

04/05/2021



Bushfire Management Plan

Armstrong Farmlands - Tiny Cabins

443 Kilpatrick Road, Nomans Lake

Shire of Narrogin

**Bushfire Policy – Specific
Development or Use Type:**

Vulnerable Land Use (Tourism)

Job Number:

201800

Assessment Date:

19 March 2021

Report Date:

4 May 2021

BPP Group Pty Ltd t/a Bushfire Prone Planning
 ACN: 39 166 551 784 | ABN: 39 166 551 784

Level 1, 159-161 James Street
 Guildford WA 6055

PO Box 388
 Guildford WA 6935

08 6477 1144 | admin@bushfireprone.com.au



DOCUMENT CONTROL

PREPARATION				
Author:	Greg Dunstan (BPAD Level 1 - No. 16382)			
Co-Author:				
Review/Authorise:	Kathy Nastov (BPAD Level 3 - No. 27794)			
VERSION HISTORY				
Version	Version Details	Date		
1.0	Original document	4 May 2021		
BMP (Standard DA-Tourism) Template v8.3				
DISTRIBUTION				
Destination	Version	No. Copies	Hard Copy	Electronic Copy
Person/Business: Planning Outcomes WA Email: matt@townplanningadvice.com.au	1.0	1	<input type="checkbox"/>	<input checked="" type="checkbox"/>
Person/Business: Heyscape Pty Ltd Email: pierre@heyscape.com.au	1.0	1	<input type="checkbox"/>	<input checked="" type="checkbox"/>
<p>Limitation of Liability: The measures contained in this Bushfire Management Plan, are considered to be minimum requirements and they do not guarantee that a building will not be damaged in a bushfire, persons injured, or fatalities occur either on the subject site or off the site while evacuating. This is substantially due to the unpredictable nature and behaviour of fire and fire weather conditions. Additionally, the correct implementation of the required bushfire protection measures will depend upon, among other things, the ongoing actions of the landowners and/or operators over which Bushfire Prone Planning has no control.</p> <p>All surveys, forecasts, projections and recommendations made in this report associated with the proposed development are made in good faith based on information available to Bushfire Prone Planning at the time. All maps included herein are indicative in nature and are not to be used for accurate calculations.</p> <p>Notwithstanding anything contained therein, Bushfire Prone Planning will not, except as the law may require, be liable for any loss or other consequences whether or not due to the negligence of their consultants, their servants or agents, arising out of the services provided by their consultants.</p> <p>Copyright ©2020 BPP Group Pty Ltd: All intellectual property rights, including copyright, in format and proprietary content contained in documents created by Bushfire Prone Planning, remain the property of BPP Group Pty Ltd. Any use made of such format or content without the prior written approval of Bushfire Prone Planning, will constitute an infringement on the rights of the Company which reserves all legal rights and remedies in respect of any such infringement.</p>				

TABLE OF CONTENTS

EXECUTIVE SUMMARY	3
1 PROPOSAL DETAILS	4
1.1 DESCRIPTION AND ASSOCIATED PLANS AND MAPS.....	4
1.2 THE SPECIFIC 'LAND USE' AND THE BUSHFIRE PLANNING REQUIREMENTS.....	8
1.3 EXISTING DOCUMENTATION RELEVANT TO THE CONSTRUCTION OF THIS PLAN	9
2 ENVIRONMENTAL CONSIDERATIONS	10
2.1 NATIVE VEGETATION – RESTRICTIONS TO MODIFICATION AND/OR CLEARING	10
3 POTENTIAL BUSHFIRE IMPACT ASSESSMENT	11
3.1 ASSESSMENT INPUT.....	11
3.1.1 Fire Danger Index (FDI) Applied	11
3.1.2 Vegetation Classification and Effective Slope	11
VEGETATION ASSESSMENT AND CLASSIFICATION	13
3.1.3 Vegetation Separation Distance	32
3.2 ASSESSMENT OUTPUT	33
3.2.1 Bushfire Attack Level Results - BAL Contour Map Format	34
3.2.2 Bushfire Attack Level Results - Derived from The BAL Contour Map	41
INDICATIVE BAL(S) FOR PROPOSED TINY CABINS	41
4 IDENTIFICATION OF BUSHFIRE HAZARD ISSUES	42
5 ASSESSMENT AGAINST THE ACCEPTABLE SOLUTIONS (POLICY MEASURES) ESTABLISHED BY THE 'TOURISM LAND USE' POSITION STATEMENT	43
5.1 LOCAL GOVERNMENT VARIATIONS TO APPLY.....	43
5.2 SUMMARY OF ASSESSMENT AGAINST THE ACCEPTABLE SOLUTIONS FOR TOURISM LAND USE	44
5.3 ASSESSMENT DETAIL	45
Element 1 (Tourism Land Use): Siting and Design of Development.....	45
Element 2 (Tourism Land Use): Vehicular Access.....	48
Element 3 (Tourism Land Use): Provision of Water	49
5.4 ADDITIONAL BUSHFIRE PROTECTION MEASURES	50
5.4.1 Additional Measures to Improve Bushfire Performance	50
5.4.2 Additional Measures Established by the Bushfire Emergency Plan.....	51
6 RESPONSIBILITIES FOR IMPLEMENTATION AND MANAGEMENT OF THE BUSHFIRE PROTECTION MEASURES	52
6.1 LANDOWNER/OCCUPIER - ONGOING.....	52
APPENDIX 1: TECHNICAL REQUIREMENTS FOR ONSITE VEGETATION MANAGEMENT	53
APPENDIX 2: TECHNICAL REQUIREMENTS FOR VEHICULAR ACCESS	56
APPENDIX 3: TECHNICAL REQUIREMENTS FOR FIREFIGHTING WATER	59

LIST OF FIGURES

Figure 1.1: Development Plan	5
Figure 1.2: Location Plan.....	6
Figure 1.3: Map of Bushfire Prone Areas for the Subject Site and Surrounds	7
Figure 3.1.1: Vegetation classification and topography map.....	27
Figure 3.1.2: Vegetation classification and topography map.....	28
Figure 3.1.3: Vegetation classification and topography map.....	29
Figure 3.1.4: Vegetation classification and topography map.....	30
Figure 3.1.5: Vegetation classification and topography map.....	31
Figure 3.2.1: BAL Contour Map.....	36
Figure 3.2.2: BAL Contour Map.....	37
Figure 3.2.3: BAL Contour Map.....	38
Figure 3.2.4: BAL Contour Map.....	39
Figure 3.2.5: BAL Contour Map.....	40

EXECUTIVE SUMMARY

This Bushfire Management Plan is to accompany a Development Application for proposed 'Tiny Cabins' which are to be located at Armstrong Farms, (No.443) Kilpatrick Road, Nomans Lake, in the Shire of Narrogin.

There are scenarios of 'vulnerable' land use (location and type of land use) for which current deemed to satisfy bushfire planning provisions (the bushfire protection criteria established by the Guidelines), and bushfire construction standards cannot always be met. 'Tourism' land use is potentially one of these. The Armstrong Farms, Nomans Lake, Tiny Cabin proposal is considered a Tourism Land Use and will be assessed against the Department of Planning, Lands and Heritage (DPLH) Position Statement for Tourism Land Uses in Bushfire Prone Areas acceptable solutions for caravan and camping grounds.

As a Tourism Land Use the proposed development is by default also considered a Vulnerable Land Use and a Bushfire Emergency Plan is required to accompany this Bushfire Management Plan. The emphasis will be on early evacuation or closure on days of an elevated fire danger rating or days where a total fire ban in the area is declared. The BEP may be conditioned at the subsequent stage of the development application post initial consideration by the Shire of Narrogin, on the merit of the development proposal.

The proposed Tiny Cabins will be situated in grassland/cropping areas and the creation of Asset Protection Zones around these sites will not require the removal of native vegetation. The 'Tiny Cabins' are constructed to a BAL-29 standard and will be subject to a corresponding BAL rating of BAL-29 through the implementation of the asset protection zones.

Access to the Tiny Cabins will be via unsealed trafficable driveways through large areas of privately owned farmland. Kilpatrick Road to the south and Yilliminning Road to the north, provide two way access to two differing locations via sealed and unsealed sections of public roads that are available to the public and emergency services at all times.

The internal private driveway to the proposed carpark areas for each Tiny Cabin site will comply with the technical requirements of the Guidelines for Planning in Bushfire prone Areas, including provision for turn-around area suitable for large fire appliances. The Tiny Cabin development will include signposting along the driveway access and at each carpark site detailing the site configuration and egress to the public road. The carpark will be large enough to accommodate the private vehicles and provide a turnaround area for fire appliances. This area is to be constructed to comply with the requirements for private driveways with respect to clearances, grade, weight capacity, crossfall and all-weather surface.

A minimum 50,000 litres of water will be dedicated for fire-fighting purposes, utilising existing static water tanks, which are located at the rear of the existing shed site, with primary access from Kilpatrick Road and will incorporate fire services connection couplings to comply with the technical requirements of the Guidelines for Planning in Bushfire prone Areas.

Water can also be drafted from dams that have permanent water all year round, a natural hard surface maintained access for vehicles to access the dam within 2.5m of the dam edge for drafting purposes and access to water through connection to above ground standpipe for fire-fighting purposes should a bushfire emergency require an additional water supply source for a bushfire burning on the subject property. The identified water supplies are not utilised for potable domestic water supply to the dwellings on the property.

1 PROPOSAL DETAILS

1.1 Description and Associated Plans and Maps

Proponent:	Heyscape Pty Ltd (T/A Tiny Cabins)
Purpose of the BMP:	To accompany a planning application
'Armstrong Farms' Lot Total Area:	Approx. 6000 hectares
Description of the Land Use:	
Development application – Addition to land use (Short-term accommodation). Bushfire management planning assessment and compliance requirement report for No.443 Kilpatrick Road, NOMANS LAKE.	

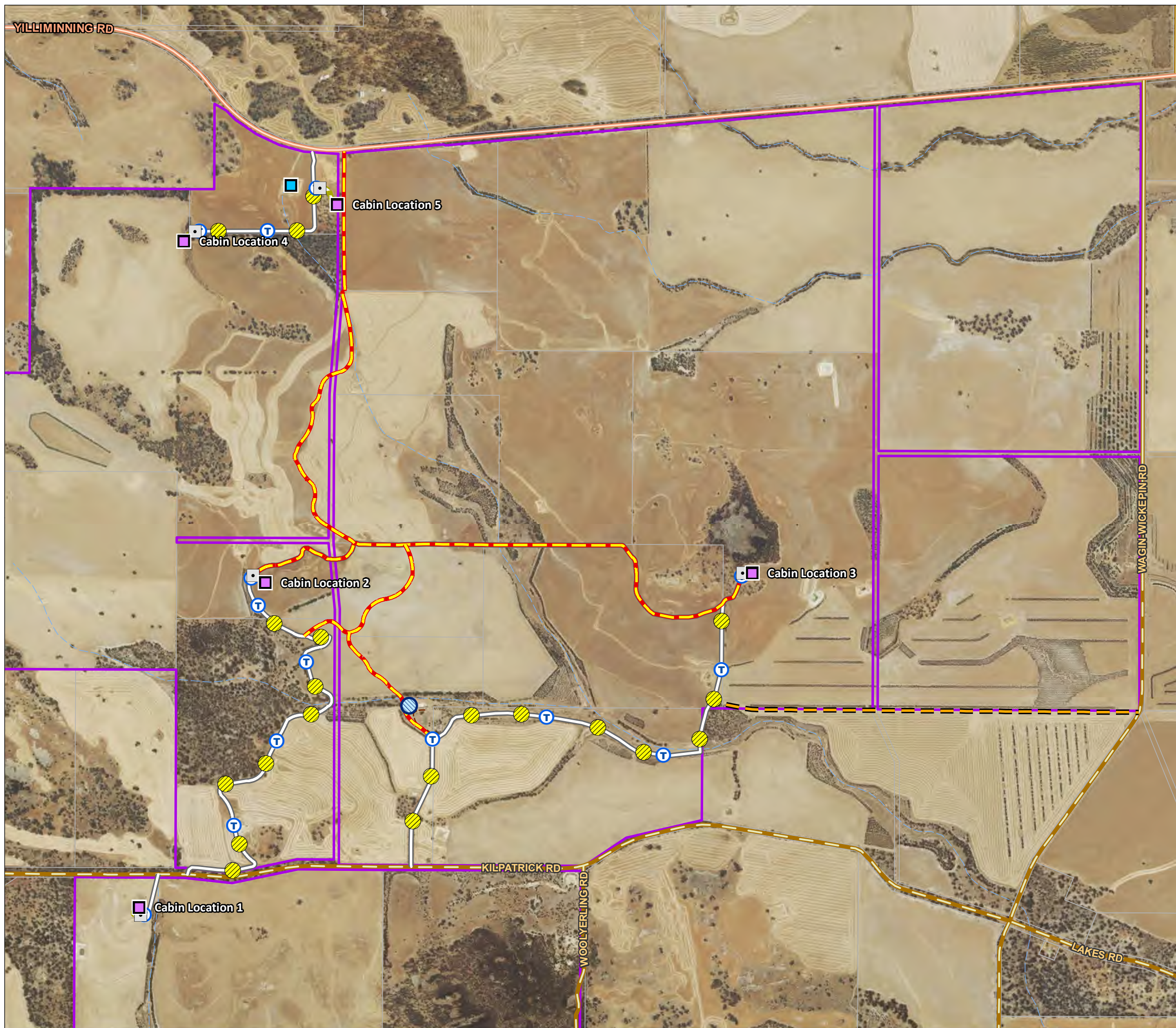
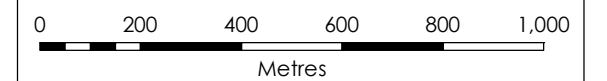

Figure 1.1
Proposed Development

Lot 5324 on Plan 118430, Area : 652,865 sq m
 443 Kilpatrick Road,
 NOMANS LAKE 6312
SHIRE OF NARROGIN

----- **LEGEND** -----

- Subject Site
 - Other Lots
 - Proposed Cabin
 - Passing Bay (20m x 6m)
 - Turnaround (20m Wide)
 - Parking
 - Fire Fighting Water Supply
 - Fire Fighting Water Tank
- Access / Egress**
- Emergency Access
 - Driveway
 - Exit Track
 - Turnaround (20m Wide)
 - Walktrack



----- **LOCALITY** -----

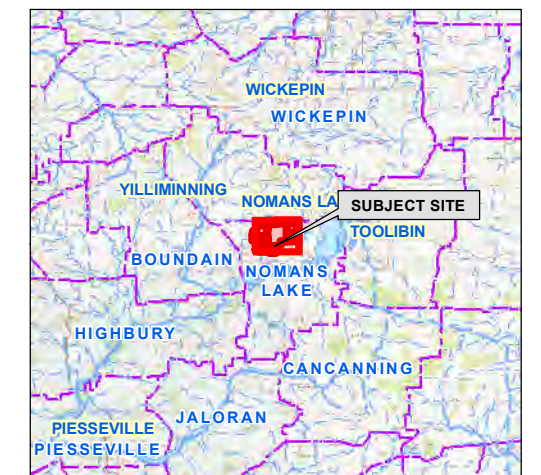

Aerial Imagery : Landgate/SLIP
 Image Date : Dec 2016



Coordinate System: GDA 1994 MGA Zone 50
 Projection: Universal Transverse Mercator Units: Metre
 Map compiled by: Ian Ross 4/05/2021
 Map updated by: Ian 4/05/2021

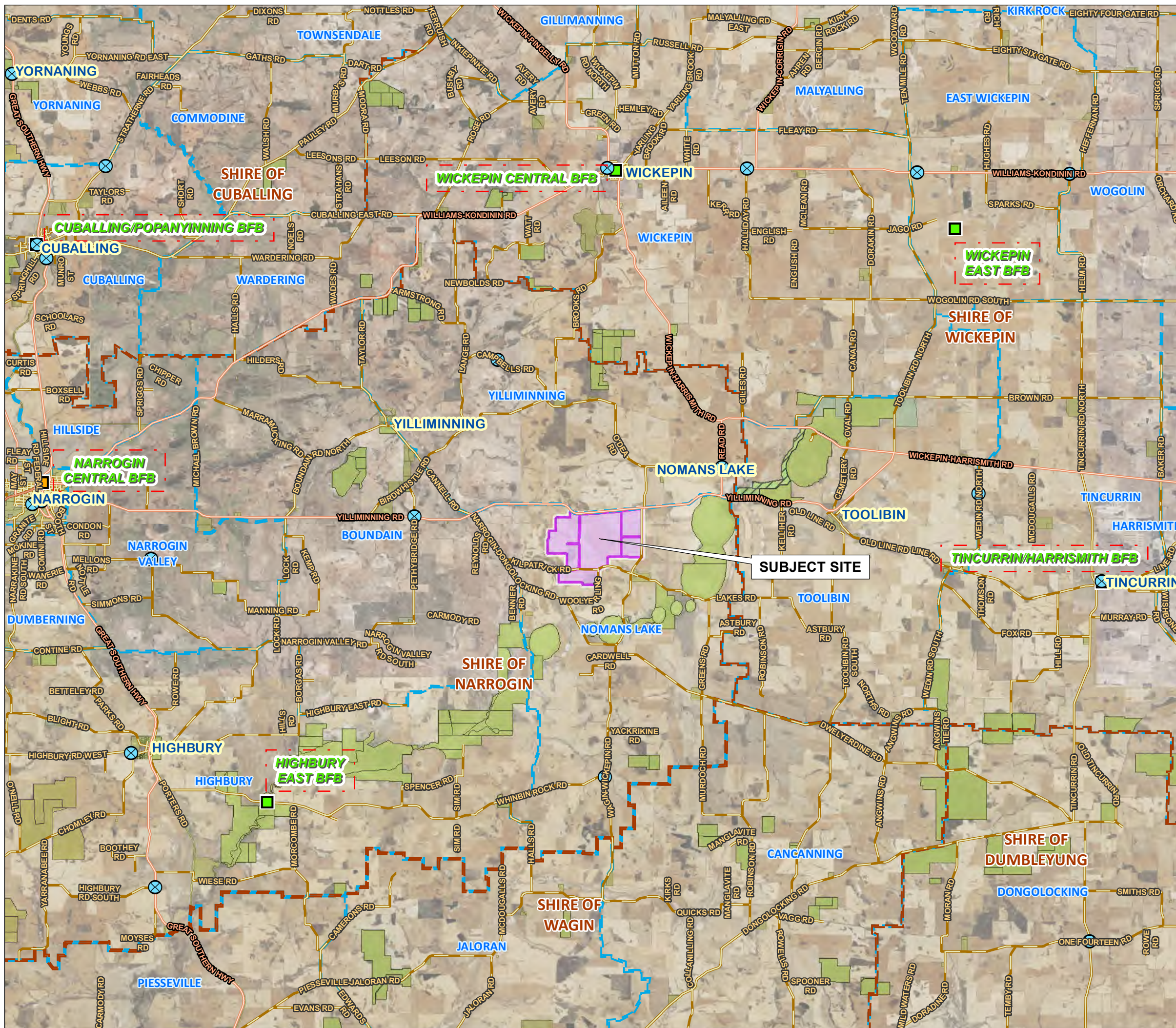
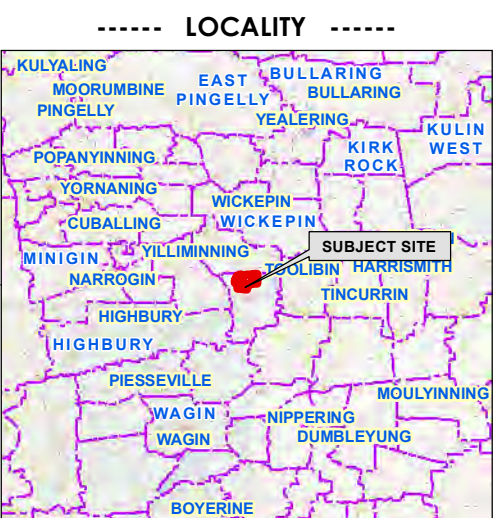
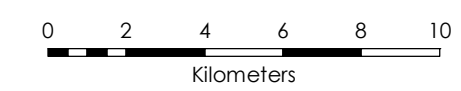

Figure 1.2
Location Plan

Lot 5324 on Plan 118430, Area : 652,865 sq m
443 Kilpatrick Road,
NOMANS LAKE 6312
SHIRE OF NARROGIN

- LEGEND -----
- Subject Site
 - Local Government Authority
 - Locality / Suburb
 - Bush Fire Brigade
 - State Emergency Service Unit
 - Volunteer Fire & Rescue Service
 - Standpipe
 - Reserves
- DBCAs Legislated Lands and Waters**
- Nature Reserve
 - Section 34A Freehold
 - Section 5(1)(g) Reserve
 - Section 5(1)(h) Reserve
 - State Forest
- DBCAs Lands of Interest**
- Crown Freehold - Dept Interest



Aerial Imagery : Landgate/SLIP
Image Date : Dec 2016

Coordinate System: GDA 1994 MGA Zone 50
Projection: Universal Transverse Mercator Units: Metre
Map compiled by: Ian Ross 4/05/2021
Map updated by: Ian 4/05/2021

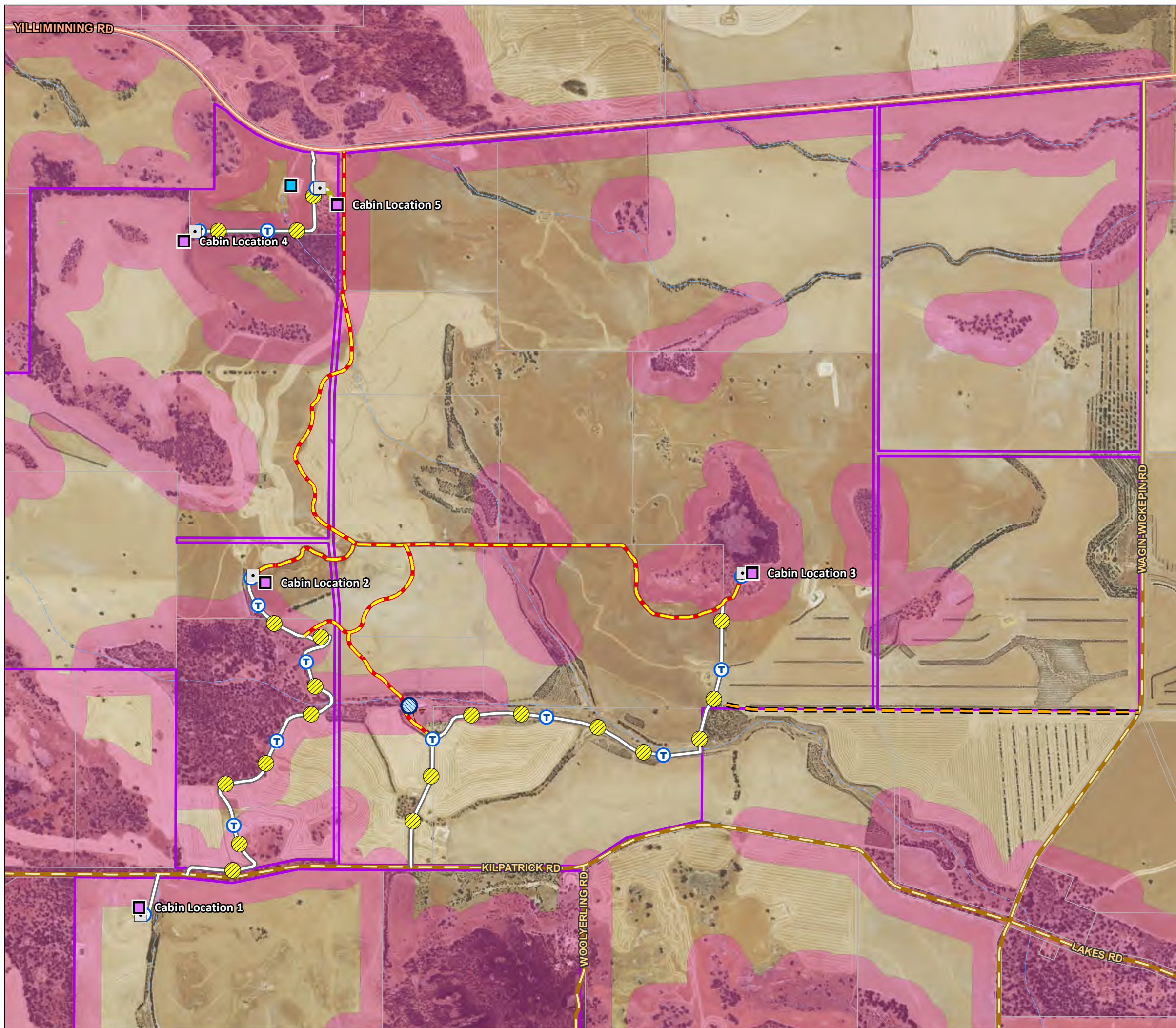
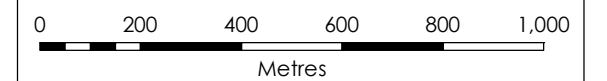

Figure 1.3
Bushfire Prone Area

Lot 5324 on Plan 118430, Area : 652,865 sq m
 443 Kilpatrick Road,
 NOMANS LAKE 6312
SHIRE OF NARROGIN

----- **LEGEND** -----

- Subject Site
- Other Lots
- Proposed Cabin
- Passing Bay (20m x 6m)
- Turnaround (20m Wide)
- Parking
- Fire Fighting Water Supply
- Fire Fighting Water Tank
- Access / Egress**
- Emergency Access
- Driveway
- Exit Track
- Turnaround (20m Wide)
- Walktrack
- Bushfire Prone Areas (2019)



----- **LOCALITY** -----

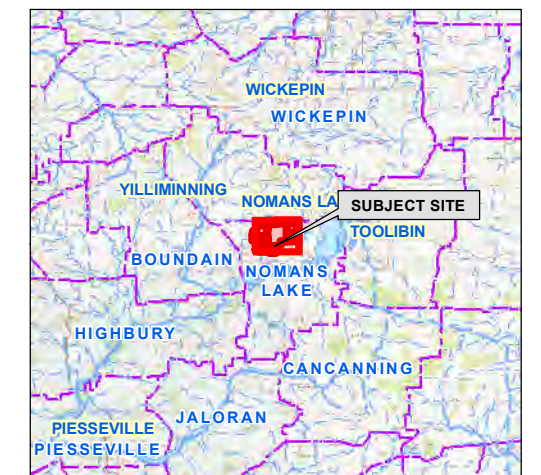

Aerial Imagery : Landgate/SLIP
 Image Date : Dec 2016



Coordinate System: GDA 1994 MGA Zone 50
 Projection: Universal Transverse Mercator Units: Metre
 Map compiled by: Ian Ross 4/05/2021
 Map updated by: Ian 4/05/2021

1.2 The Specific 'Land Use' and the Bushfire Planning Requirements

SPP 3.7, the associated Guidelines and Position Statements, define certain land uses that require additional and/or alternative bushfire related assessment and additional information to be provided. This is necessary to facilitate future planning application assessment and for subsequent operational use.

When such a future proposal is unable to fully achieve the implementation of all required bushfire protection measures - as established by the 'acceptable solutions' contained in the Guidelines and Position Statements – further assessments and the development of additional protection measures are required.

The land use classification that applies to the **Armstrong Farms, Tiny Cabins** is identified in Table 1.2, along with the required additional assessments and information and the form and location in which this is provided.

Table 1.2: The determined land use and assessment/information requirements.

THE LAND USE CLASSIFICATION AND BUSHFIRE PLANNING REQUIREMENTS		
Assessment / Information / Documents Detail		
The proposed land use classification is determined to be:		Vulnerable (Tourism)
Category, type and/or operations of the land use that have determined the classification:		Other Vulnerable Short Term Accommodation or Vulnerable Day Uses
The Policies, Guidelines and Position Statements against which the proposed land use will be assessed, and which guide the information to be provided. ¹	SPP 3.7	<input checked="" type="checkbox"/>
	Guidelines including the BPC	n/a
	Guidelines excluding the BPC	<input checked="" type="checkbox"/>
	Position Statement - BPC Element 1 and 2	<input checked="" type="checkbox"/>
	Position Statement - Tourism	<input checked="" type="checkbox"/>
The documents and the information developed and the format and location in which they are provided.	Bushfire Management Plan (BMP)	<input checked="" type="checkbox"/> Separate Document
	Risk Management Plan (RMP)	n/a
	Risk Assessment and Treatment Plan	<input type="checkbox"/> Addendum to BMP
	Vulnerability Assessment - Short Stay Accommodation/Visitation (supporting BMP and BEP)	<input type="checkbox"/> Addendum to BMP and <input type="checkbox"/> Addendum to BEP
	Bushfire Emergency Plan (BEP)	<input checked="" type="checkbox"/> *Separate Document
	BEP Supporting Information	<input type="checkbox"/> Addendum to BEP
	Additional bushfire protection measures	<input checked="" type="checkbox"/> In BMP s5.4
	Owner/operator additional responsibilities associated with the land use.	<input checked="" type="checkbox"/> In BMP s6.0
<p>Note 1: State Planning Policy 3.7 Planning in Bushfire Prone Areas; Guidelines for Planning in Bushfire Prone Areas WAPC 2017 v1.3; Bushfire Protection Criteria (BPC) established in the Guidelines; Position Statement: Planning in bushfire prone areas – Demonstrating Element 1: Location and Element 2: Siting and design WAPC November 2019; Position Statement: Tourism land uses in bushfire prone areas WAPC October 2019.</p>		

*To be provided subject to consideration of the development proposal by the Shire of Narrogin.

1.3 Existing Documentation Relevant to the Construction of this Plan

This section acknowledges any known reports or plans that have been prepared for previously, that refer to the subject area and that may or will impact upon the assessment of bushfire risk and/or the implementation of bushfire protection measures and will be referenced in this Bushfire Management Plan.

Table 2.1: Existing relevant documentation.

RELEVANT EXISTING DOCUMENTS		
Existing Document	Copy Provided by Client	Title
Structure Plan	-	N/A
Environmental Report	-	N/A
Landscaping (Revegetation) Plan	-	N/A
Bushfire Risk Assessments	-	N/A

2 ENVIRONMENTAL CONSIDERATIONS

2.1 Native Vegetation – Restrictions to Modification and/or Clearing

Many bushfire prone areas also have high biodiversity values. SPP 3.7 policy objective 5.4 recognises the need to consider bushfire risk management measures alongside environmental, biodiversity and conservation values (Guidelines s2.3).

There is a requirement to identify any need for onsite modification and/or clearing of native vegetation and whether this may trigger potential environmental impact/referral requirements under State and Federal environmental legislation. Confirmation that any proposed native vegetation modification and/or clearing is acceptable, should be received from the relevant agencies by the proponent and provided to the bushfire consultant for inclusion in the Bushfire Management Plan if it will influence the required bushfire planning assessments and outcomes. The following table details any potential environmental restrictions of which the author of this report is aware.

Table 2.2: Native vegetation and potential environmental considerations and restrictions.

NATIVE VEGETATION MODIFICATION / CLEARING - POTENTIAL ENVIRONMENTAL RESTRICTIONS IDENTIFIED			
Environmental Consideration / Feature	Mapping Data Source (SLIP / Local Planning)	Relevant to Proposed Development	Comment/Description (as required)
Will onsite clearing of native vegetation be required?		Yes	Asset protection zones will require modification of some vegetation to maintain a low threat status
Might environmental impact/referral requirements under State and Federal environmental legislation be triggered?		Unaware	-
National Park / Nature Reserve	DBCA-011	N/A	-
Conservation Covenants	DPIRD-023	No	-
Bush Forever Sites	DPLH-019	No	-
RAMSAR Wetlands	DBCA-010	No	-
Geomorphic and Other Wetlands	DBCA-011-019, 040, 043, 044	No	-
Threatened Ecological Communities (TECs)	DBCA-038	Unaware	-
Declared Rare Flora (DRFs)	DBCA-036	Unaware	-
Land Identified as significant through a Local Biodiversity Strategy	L/G - Intramaps	N/A	-
Statement of how the identified environmental feature is dealt with in this Bushfire Management Plan:			
The assessments and bushfire protection measures detailed the BMP, assume that environmental approval will be achieved or clearing permit exemptions will apply.			
It is advised that the proponent seek further advice from an Environmental Consultant or the WA Department of Biodiversity Conservation and Attractions for further information on the condition and species contained within the proposed development area and the requirement for referral of the proposal.			

3 POTENTIAL BUSHFIRE IMPACT ASSESSMENT

3.1 Assessment Input

3.1.1 Fire Danger Index (FDI) Applied

AS 3959:2018 Table 2.1 specifies the fire danger index values to apply for different regions. The values used in the model calculations are for the Forest Fire Danger Index (FFDI) and for which equivalent representative values of the Grassland Fire Danger Index (GFDI) are applied as per Appendix B. The values can be modified if appropriately justified.

Table 3.1: Applied FDI Value

FDI VALUE			
Vegetation Areas	As per AS 3959:2018 Table 2.1	As per DFES for the Location	Value Applied
All	80	N/A	80

3.1.2 Vegetation Classification and Effective Slope

Classification: Bushfire prone vegetation identification and classification has been conducted in accordance with AS 3959:2018 s2.2.3 and the Visual Guide for Bushfire Risk Assessment in WA (DoP February 2016).

When more than one vegetation type is present, each type is identified separately, and the applied classification considers the potential bushfire intensity and behaviour from the vegetation types present and ensures the worst case scenario is accounted for – this may not be from the predominant vegetation type.

The vegetation structure has been assessed as it will be in its mature state (rather than what might be observed on the day). Areas of modified vegetation are assessed as they will be in their natural unmodified state (unless maintained in a permanently low threat, minimal fuel condition, satisfying AS 3959:2018 s2.2.3.2(f) and asset protection zone standards). Vegetation destroyed or damaged by a bushfire or other natural disaster has been assessed on its revegetated mature state.

Effective Slope: Refers to the ground slope under each area of classified vegetation which most influences the bushfire attack (and is described in the direction relative to the view from the building or proposed development site). This slope has a direct and significant influence on the fire's rate of spread and intensity.

Where there is a significant change in effective slope under an area of classified vegetation, that will cause a change in fire behaviour, separate vegetation areas will be identified to enable the correct assessment.

When the effective slope, under a given area of bushfire prone vegetation, will be different relative to multiple proposed development sites, then the effective slopes corresponding to the different locations, are separately identified.

Table 3.2: Vegetation classification and effective slope (Indicative Cabin Locations)

ALL VEGETATION WITHIN 150 METRES OF THE ARMSTRONG FARMS - TINY CABIN LOCATION 1				
Vegetation Area	Identified Vegetation Types ¹ or Description if 'Excluded'	Applied Vegetation Classification ¹	Effective Slope (degrees) ²	
			Assessed	Applied Range
1	Closed tussock grassland G-21; Sown pasture G-26	Class G Grassland	0	upslope or flat
2	Closed tussock grassland G-21; Sown pasture G-26	Class G Grassland	1.6	downslope >0-5
3	Closed scrub D-13; Open scrub D-14 ; Tall shrubland E-15	Class D Scrub	0	upslope or flat
4	Closed scrub D-13; Open scrub D-14 ; Tall shrubland E-15	Class D Scrub	1.5	downslope >0-5
Representative photos of each vegetation area, descriptions and classification justification, are presented on the following pages. The areas of classified vegetation are defined, and the photo locations identified on Figure 3.1, the vegetation and topography map.				
Note ¹ : Described and classified as per AS 3959:2018 Table 2.3 and Figures 2.3 and 2.4 (A)-(H)				
Note ² : Effective slope measured as per AS 3959:2018 Section 2.2.5 and Appendix B Part B4				

ALL VEGETATION WITHIN 150 METRES OF THE ARMSTRONG FARMS - TINY CABIN LOCATION 2				
Vegetation Area	Identified Vegetation Types ¹ or Description if 'Excluded'	Applied Vegetation Classification ¹	Effective Slope (degrees) ²	
			Assessed	Applied Range
5	Closed tussock grassland G-21; Sown pasture G-26	Class G Grassland	2.4	downslope >0-5
6	Closed tussock grassland G-21; Sown pasture G-26	Class G Grassland	0	upslope or flat
7	Closed scrub D-13; Open scrub D-14 ; Tall shrubland E-15	Class D Scrub	0	upslope or flat
8	Open forest A-03; Low woodland B-07; Open scrub D-14	Class A Forest	0	upslope or flat
Representative photos of each vegetation area, descriptions and classification justification, are presented on the following pages. The areas of classified vegetation are defined, and the photo locations identified on Figure 3.1, the vegetation and topography map.				
Note ¹ : Described and classified as per AS 3959:2018 Table 2.3 and Figures 2.3 and 2.4 (A)-(H)				
Note ² : Effective slope measured as per AS 3959:2018 Section 2.2.5 and Appendix B Part B4				

ALL VEGETATION WITHIN 150 METRES OF THE ARMSTRONG FARMS - TINY CABIN LOCATION 3				
Vegetation Area	Identified Vegetation Types ¹ or Description if 'Excluded'	Applied Vegetation Classification ¹	Effective Slope (degrees) ²	
			Assessed	Applied Range
9	Closed tussock grassland G-21; Sown pasture G-26	Class G Grassland	0	upslope or flat
10	Closed scrub D-13; Open scrub D-14 ; Tall shrubland E-15	Class D Scrub	0	upslope or flat
11	Open forest A-03; Low woodland B-07; Open scrub D-14	Class A Forest	0	upslope or flat
Representative photos of each vegetation area, descriptions and classification justification, are presented on the following pages. The areas of classified vegetation are defined, and the photo locations identified on Figure 3.1, the vegetation and topography map.				
Note ¹ : Described and classified as per AS 3959:2018 Table 2.3 and Figures 2.3 and 2.4 (A)-(H)				
Note ² : Effective slope measured as per AS 3959:2018 Section 2.2.5 and Appendix B Part B4				

ALL VEGETATION WITHIN 150 METRES OF THE ARMSTRONG FARMS - TINY CABIN LOCATION 4				
Vegetation Area	Identified Vegetation Types ¹ or Description if 'Excluded'	Applied Vegetation Classification ¹	Effective Slope (degrees) ²	
			Assessed	Applied Range
12	Closed tussock grassland G-21; Sown pasture G-26	Class G Grassland	0	upslope or flat
13	Closed tussock grassland G-21; Sown pasture G-26	Class G Grassland	3.8	downslope >0-5
14	Closed tussock grassland G-21; Sown pasture G-26	Class G Grassland	4.0	downslope >0-5
15	Low shrubland C-12; Sparse open tussock G-24	Class C Shrubland	6.7	downslope >5-10
16	Open forest A-03; Low woodland B-07; Open scrub D-14	Class A Forest	4.6	downslope >0-5
Representative photos of each vegetation area, descriptions and classification justification, are presented on the following pages. The areas of classified vegetation are defined, and the photo locations identified on Figure 3.1, the vegetation and topography map.				
Note ¹ : Described and classified as per AS 3959:2018 Table 2.3 and Figures 2.3 and 2.4 (A)-(H)				
Note ² : Effective slope measured as per AS 3959:2018 Section 2.2.5 and Appendix B Part B4				

ALL VEGETATION WITHIN 150 METRES OF THE ARMSTRONG FARMS - TINY CABIN LOCATION 5				
Vegetation Area	Identified Vegetation Types ¹ or Description if 'Excluded'	Applied Vegetation Classification ¹	Effective Slope (degrees) ²	
			Assessed	Applied Range
17	Closed tussock grassland G-21; Sown pasture G-26	Class G Grassland	0	upslope or flat
18	Closed tussock grassland G-21; Sown pasture G-26	Class G Grassland	2.6	downslope >0-5
19	Woodland B-05; Low woodland B-07	Class B Woodland	3.6	downslope >0-5
Representative photos of each vegetation area, descriptions and classification justification, are presented on the following pages. The areas of classified vegetation are defined, and the photo locations identified on Figure 3.1, the vegetation and topography map.				
Note ¹ : Described and classified as per AS 3959:2018 Table 2.3 and Figures 2.3 and 2.4 (A)-(H)				
Note ² : Effective slope measured as per AS 3959:2018 Section 2.2.5 and Appendix B Part B4				

Table 3.3: Vegetation assessment and classification (Indicative Cabin Locations)

VEGETATION ASSESSMENT AND CLASSIFICATION
In accordance with AS 3959:2018 Section 2, clause 2.2.3, FPA Australia guidance and the Visual Guide for Bushfire Risk Assessment in WA (DoP February 2016), all vegetation within 150 metres of the site (part of the lot on which a building stands or is to be erected) is assessed and classified. Vegetation of any type more than 100m from the site is excluded from the BAL assessment.

TINY CABIN LOCATION 1

AS 3959:2018 Vegetation Classification Applied:	Class G Grassland
Vegetation Types Present:	Sown pasture G-26; Closed tussock grassland G-21 (Commercial Crops)
Description/Justification:	Cabin site – Cropping land and pasture currently maintained below 100mm in height.
Post Development Assumptions:	Asset protection zones are able to be constructed/developed around each cabin site. Cropping land and pasture grasses will be maintained below 100mm in height within the asset protection zone.

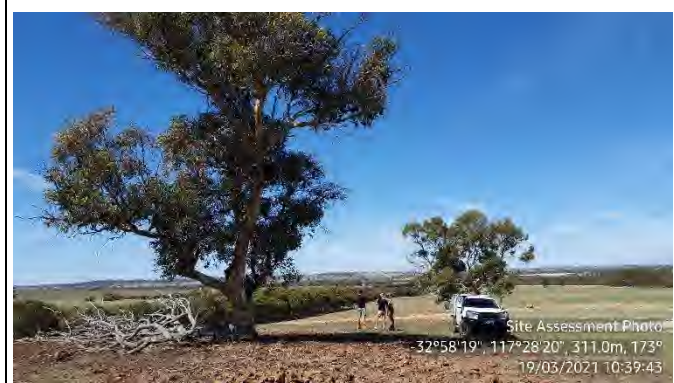

AS 3959:2018 Vegetation Classification Applied:	Class G Grassland
Vegetation Types Present:	Sown pasture G-26; Closed tussock grassland G-21 (Commercial Crops)
Description/Justification:	Cropping land and pasture currently reduced <100mm in height. Classified on worst case scenario.
Post Development Assumptions:	Cropping land and pasture areas are classifiable due to seasonal growth outside of cabin asset protection zone.

Photo ID: 1	Photo ID: 2
-------------	-------------



Photo ID: 3	Photo ID: 4
-------------	-------------

TINY CABIN LOCATION 1



Photo ID: 5

Photo ID: 6

TINY CABIN LOCATION 1

AS 3959:2018 Vegetation Classification Applied: Class D Scrub

Vegetation Types Present: Closed scrub D-13; Open scrub D-14 ; Tall shrubland E-15

Description/Justification: Scrub comprising medium to tall shrubs >2m in height and low trees up to 6m in height with multi-stemmed appearance, >30% foliage cover, with grass understorey.

Post Development Assumptions: Vegetation likely to remain. Windbreaks and remnant standing vegetation, adjacent cropping and pasture land.



Photo ID: 7

Photo ID: 8

TINY CABIN LOCATION 2

AS 3959:2018 Vegetation Classification Applied:	Class G Grassland
Vegetation Types Present:	Sown pasture G-26; Closed tussock grassland G-21 (Commercial Crops)
Description/Justification:	Cabin site – Cropping land and pasture currently maintained below 100mm in height.
Post Development Assumptions:	Asset protection zones are able to be constructed/developed around each cabin site. Cropping land and pasture grasses will be maintained below 100mm in height within the asset protection zone.



Photo ID: 9

Photo ID: 10

AS 3959:2018 Vegetation Classification Applied:	Class G Grassland
Vegetation Types Present:	Sown pasture G-26; Closed tussock grassland G-21 (Commercial Crops)
Description/Justification:	Cropping land and pasture currently reduced <100mm in height. Classified on worst case scenario.
Post Development Assumptions:	Cropping land and pasture areas are classifiable due to seasonal growth outside of cabin asset protection zone.



Photo ID: 11

Photo ID: 12

TINY CABIN LOCATION 2



Photo ID: 13

Photo ID: 14

TINY CABIN LOCATION 2

AS 3959:2018 Vegetation Classification Applied: Class D Scrub

Vegetation Types Present: Closed scrub D-13; Open scrub D-14 ; Tall shrubland E-15



Description/Justification: Scrub comprising medium to tall shrubs >2m in height and low trees up to 6m in height with multi-stemmed appearance, >30% foliage cover, with grass understorey.



Post Development Assumptions: Vegetation likely to remain. Windbreaks and remnant standing vegetation, adjacent cropping and pasture land.



Photo ID: 15

Photo ID: 16

TINY CABIN LOCATION 2	
AS 3959:2018 Vegetation Classification Applied:	Class A Forest
Vegetation Types Present:	Open forest A-03; Low woodland B-07; Open scrub D-14
Description/Justification:	Mixed composition of tall trees 20m in height, with understorey of scrub comprising medium to tall shrubs >2m in height and low trees up to 6m in height with multi-stemmed appearance, ~60% foliage cover, with grass understorey.
Post Development Assumptions:	Vegetation likely to remain. Windbreaks and areas of standing vegetation, adjacent cropping and pasture land.
	
Photo ID: 17	
	
Photo ID: 18	

TINY CABIN LOCATION 3	
AS 3959:2018 Vegetation Classification Applied:	Class G Grassland
Vegetation Types Present:	Sown pasture G-26; Closed tussock grassland G-21 (Commercial Crops)
Description/Justification:	Cabin site – Cropping land and pasture currently maintained below 100mm in height.
Post Development Assumptions:	Asset protection zones are able to be constructed/developed around each cabin site. Cropping land and pasture grasses will be maintained below 100mm in height within the asset protection zone.
	
Photo ID: 19	
	
Photo ID: 20	

TINY CABIN LOCATION 3

AS 3959:2018 Vegetation Classification Applied:	Class A Forest
Vegetation Types Present:	Open forest A-03; Low woodland B-07; Open scrub D-14
Description/Justification:	Mixed composition of tall trees up to 10m in height, with understorey of scrub comprising medium to tall shrubs >2m in height and low trees up to 6m in height with multi-stemmed appearance, ~60% foliage cover, with grass understorey.
Post Development Assumptions:	Vegetation likely to remain. Windbreaks and areas of standing vegetation, adjacent cropping and pasture land.



Photo ID: 21



Photo ID: 22

TINY CABIN LOCATION 3

AS 3959:2018 Vegetation Classification Applied:	Class G Grassland
Vegetation Types Present:	Sown pasture G-26; Closed tussock grassland G-21 (Commercial Crops)
Description/Justification:	Cropping land and pasture currently reduced <100mm in height. Classified on worst case scenario.
Post Development Assumptions:	Cropping land and pasture areas are classifiable due to seasonal growth outside of cabin asset protection zone.



Photo ID: 23



Photo ID: 24

TINY CABIN LOCATION 3



Photo ID: 25



Photo ID: 26

TINY CABIN LOCATION 3

AS 3959:2018 Vegetation Classification Applied:		Class D Scrub;
Vegetation Types Present:	Closed scrub D-13; Open scrub D-14 ; Tall shrubland E-15	
Description/Justification:	Predominantly scrub comprising medium to tall shrubs >2m in height and low trees up to 6m in height with multi-stemmed appearance, >30% foliage cover, with grass understorey.	
Post Development Assumptions:	Vegetation likely to remain. Windbreaks and remnant standing vegetation, adjacent cropping and pasture land.	



Photo ID: 27



Photo ID: 28

TINY CABIN LOCATION 3

AS 3959:2018 Vegetation Classification Applied:	Class D Scrub;
Vegetation Types Present:	Closed scrub D-13; Open scrub D-14 ; Tall shrubland E-15
Description/Justification:	Predominantly scrub comprising medium to tall shrubs >2m in height and low trees up to 6m in height with multi-stemmed appearance, >30% foliage cover, with grass understorey.
Post Development Assumptions:	Vegetation likely to remain. Windbreaks and remnant standing vegetation, adjacent cropping and pasture land.



Photo ID: 29

Photo ID: 30

TINY CABIN LOCATION 4

AS 3959:2018 Vegetation Classification Applied:	Class G Grassland
Vegetation Types Present:	Sown pasture G-26; Closed tussock grassland G-21 (Commercial Crops)
Description/Justification:	Cabin site – Cropping land and pasture currently maintained below 100mm in height, adjoining shrubland.
Post Development Assumptions:	Asset protection zones are able to be constructed/developed around each cabin site. Cropping land and pasture grasses will be maintained below 100mm in height within the asset protection zone. Shrubland to be removed within asset protection zone to APZ standards.



Photo ID: 31

Photo ID: 32

TINY CABIN LOCATION 4

AS 3959:2018 Vegetation Classification Applied:	Class G Grassland
Vegetation Types Present:	Sown pasture G-26; Closed tussock grassland G-21 (Commercial Crops)
Description/Justification:	Cropping land and pasture currently reduced <100mm in height. Classified on worst case scenario.
Post Development Assumptions:	Cropping land and pasture areas are classifiable due to seasonal growth outside of cabin asset protection zone.



Photo ID: 33

Photo ID: 34



Photo ID: 35

Photo ID: 36

TINY CABIN LOCATION 4

AS 3959:2018 Vegetation Classification Applied: Class A Forest

Vegetation Types Present: Open forest A-03; Low woodland B-07; Open scrub D-14

Description/Justification: Mixed composition of tall trees up to 18m in height, with understorey of scrub comprising medium to tall shrubs >2m in height and low trees up to 6m in height with multi-stemmed appearance, ~60% foliage cover, with grass understorey.

Post Development Assumptions: Vegetation likely to remain. Windbreaks and areas of standing vegetation, adjacent cropping and pasture land.



Photo ID: 37



Photo ID: 38

TINY CABIN LOCATION 4

AS 3959:2018 Vegetation Classification Applied: Class C Shrubland

Vegetation Types Present: Low shrubland C-12; Sparse open tussock G-24

Description/Justification: Mixed composition of low shrubs <1m in height and ~30% foliage cover, grass interspersed with shrubland.

Post Development Assumptions: Vegetation likely to remain on embankment to limit soil erosion.

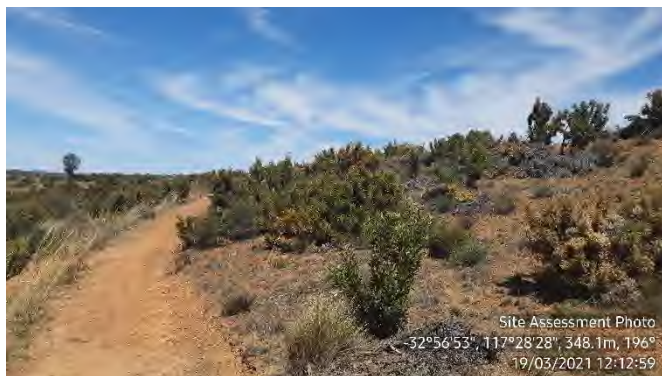

Photo ID: 39



Photo ID: 40

TINY CABIN LOCATION 5

AS 3959:2018 Vegetation Classification Applied:	Class G Grassland ; Excluded as per Section 2.2.3.2 (e)
Vegetation Types Present:	Sown pasture G-26; Non vegetated areas
Description/Justification:	Cabin site – Gravel areas interspersed with pasture currently maintained below 100mm in height.
Post Development Assumptions:	Asset protection zones are able to be constructed/developed around each cabin site. Cropping land and pasture grasses will be maintained below 100mm in height within the asset protection zone..



Photo ID: 41

Photo ID: 42

TINY CABIN LOCATION 5

AS 3959:2018 Vegetation Classification Applied:	Class G Grassland
Vegetation Types Present:	Sown pasture G-26; Closed tussock grassland G-21 (Commercial Crops)
Description/Justification:	Cropping land and pasture currently reduced <100mm in height. Classified on worst case scenario.
Post Development Assumptions:	Cropping land and pasture areas are classifiable due to seasonal growth outside of cabin asset protection zone.



Photo ID: 43

Photo ID: 44

TINY CABIN LOCATION 5



Photo ID: 45

Photo ID: 46

TINY CABIN LOCATION 5

AS 3959:2018 Vegetation Classification Applied:

Class B Woodland

Vegetation Types Present:

Woodland B-05; Low woodland B-07

Description/Justification:

Mixed composition of tall trees, including Wandoo, up to 20m in height, with understorey of low trees up to 6m in height with multi-stemmed appearance, ~30% foliage cover, with grass understorey.

Post Development Assumptions:

Vegetation likely to remain. Areas of standing vegetation, adjacent cropping and pasture land.



Photo ID: 47

Photo ID: 48

TINY CABIN LOCATION 5

AS 3959:2018 Vegetation Classification Applied:	Excluded as per Section 2.2.3.2 (e)
Vegetation Types Present:	Non-vegetated Area
Description/Justification:	Cleared gravel areas and driveway/firebreak access. Area devoid of vegetation likely to be conducive to bushfire run.
Post Development Assumptions:	It is reasonable to expect the existing cleared gravel area to remain as low threat. Previously used for gravel storage/extraction and currently provides vehicle parking and driveway access from Yillminning Road.



Photo ID: 49



Photo ID: 50

Figure 3.1.1
Topography & Classified Vegetation

CABIN LOCATION 1
 Lot 5324 on Plan 118430, Area : 652,865 sq m
 443 Kilpatrick Road,
 NOMANS LAKE 6312
SHIRE OF NARROGIN



----- **LEGEND** -----

- Subject Site
- Other Lots
- Proposed Building**
- Proposed Cabin
- Carpark
- ↔ Photo & Direction
- Asset Protection**
- Indicative Proposed APZ
- Driveway
- Turnaround (20m Wide)
- Walktrack
- Vegetation Assessment Area**
- 150m from Subject Site
- 100m from Subject Site
- Classified Vegetation**
- Class (D) Scrub
- Class (G) Grassland
- Exclusion 2.2.3.2
- ↔ APZ Distance

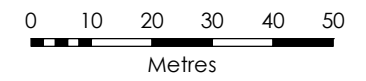

----- **LOCALITY** -----

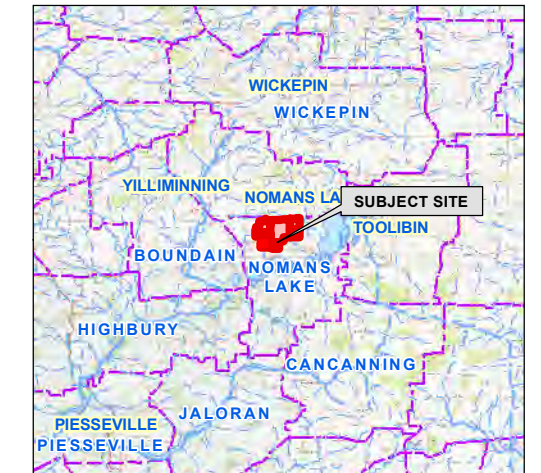

Aerial Imagery : Landgate/SLIP
 Image Date : Dec 2016

Coordinate System: GDA 1994 MGA Zone 50
 Projection: Universal Transverse Mercator Units: Metre
 Map compiled by: Ian Ross 4/05/2021
 Map updated by: Ian 4/05/2021

Figure 3.1.2
**Topography &
 Classified Vegetation**

CABIN LOCATION 2
 Lot 5324 on Plan 118430, Area : 652,865 sq m
 443 Kilpatrick Road,
 NOMANS LAKE 6312
SHIRE OF NARROGIN

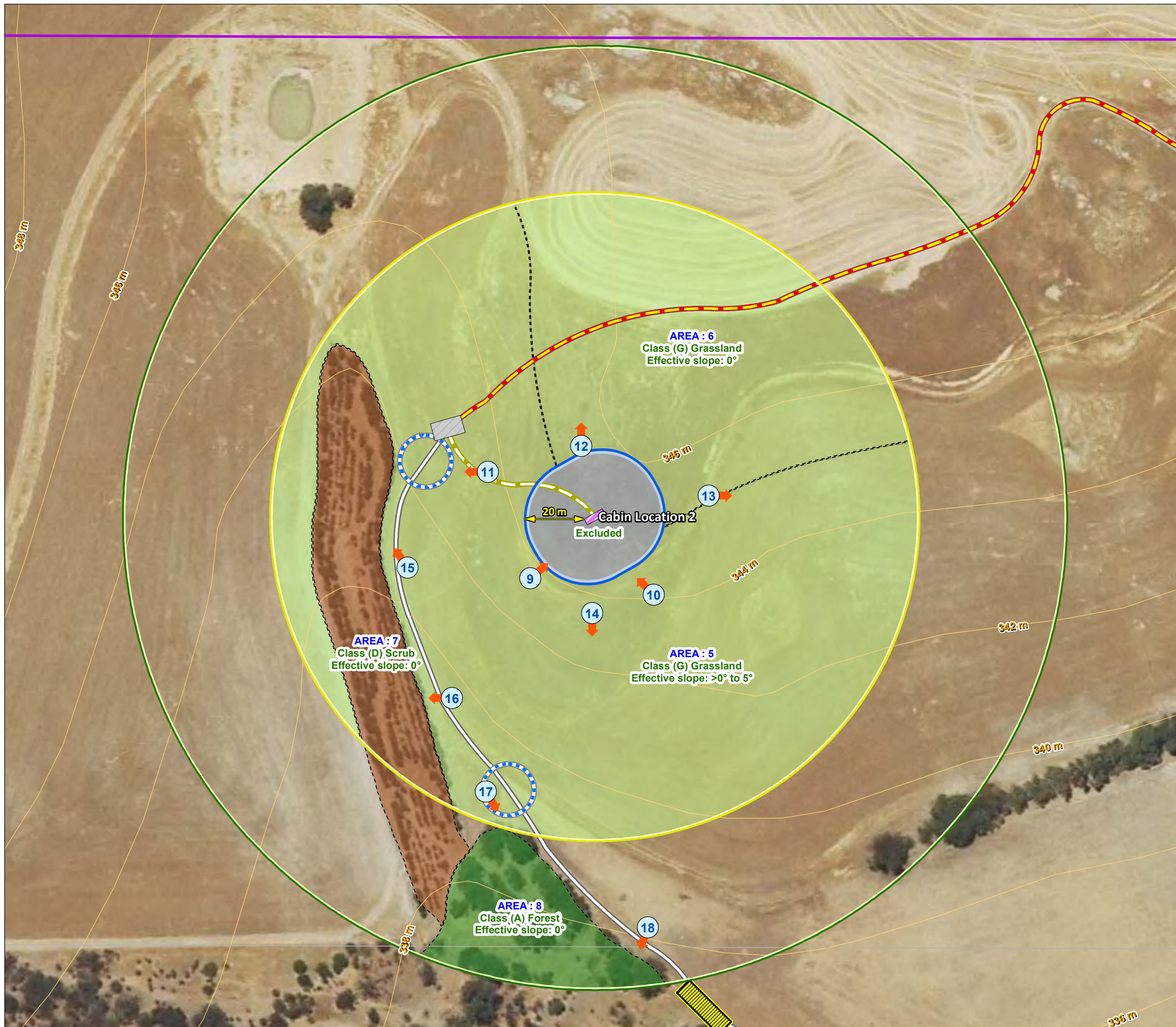

----- **LEGEND** -----

- Subject Site
- Other Lots
- Proposed Building**
- Proposed Cabin
- Carpark
- ↻ Photo & Direction
- Asset Protection**
- Indicative Proposed APZ
- Access / Egress**
- Emergency Access
- Driveway
- Turnaround (20m Wide)
- Walktrack
- Passing Bay (20m x 6m)
- Vegetation Assessment Area**
- 150m from Subject Site
- 100m from Subject Site
- Classified Vegetation**
- Class (A) Forest
- Class (D) Scrub
- Class (G) Grassland
- Exclusion 2.2.3.2
- ↔ APZ Distance



----- **LOCALITY** -----

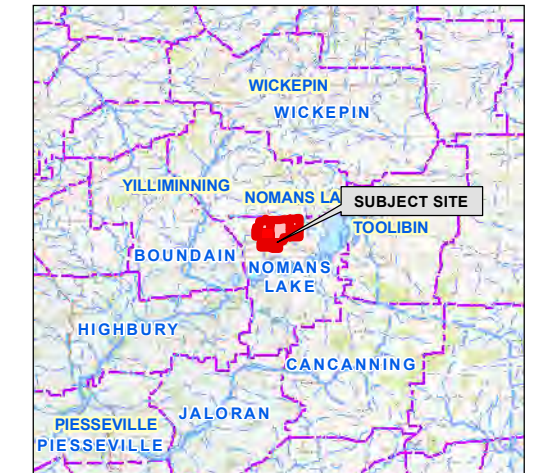

Aerial Imagery : Landgate/SLIP
 Image Date : Dec 2016

Coordinate System: GDA 1994 MGA Zone 50
 Projection: Universal Transverse Mercator Units: Metre
 Map compiled by: Ian Ross 4/05/2021
 Map updated by: Ian 4/05/2021

Figure 3.1.3
**Topography &
 Classified Vegetation**

CABIN LOCATION 3
 Lot 5324 on Plan 118430, Area : 652,865 sq m
 443 Kilpatrick Road,
 NOMANS LAKE 6312
SHIRE OF NARROGIN



----- **LEGEND** -----

- Subject Site
- Other Lots
- Proposed Building**
- Proposed Cabin
- Carpark
- ↔ Photo & Direction
- Asset Protection**
- Indicative Proposed APZ
- Access / Egress**
- Emergency Access
- Driveway
- Turnaround (20m Wide)
- Walktrack
- Vegetation Assessment Area**
- 150m from Subject Site
- 100m from Subject Site
- Classified Vegetation**
- Class (A) Forest
- Class (D) Scrub
- Class (G) Grassland
- Exclusion 2.2.3.2
- ↔ APZ Distance

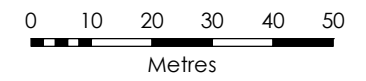

----- **LOCALITY** -----

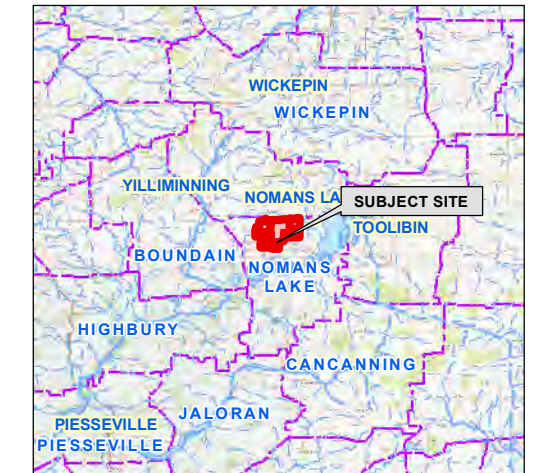

Aerial Imagery : Landgate/SLIP
 Image Date : Dec 2016

Coordinate System: GDA 1994 MGA Zone 50
 Projection: Universal Transverse Mercator Units: Metre
 Map compiled by: Ian Ross 4/05/2021
 Map dated by: Ian 4/05/2021

Figure 3.1.4
Topography & Classified Vegetation

CABIN LOCATION 4
 Lot 5324 on Plan 118430, Area : 652,865 sq m
 443 Kilpatrick Road,
 NOMANS LAKE 6312
SHIRE OF NARROGIN

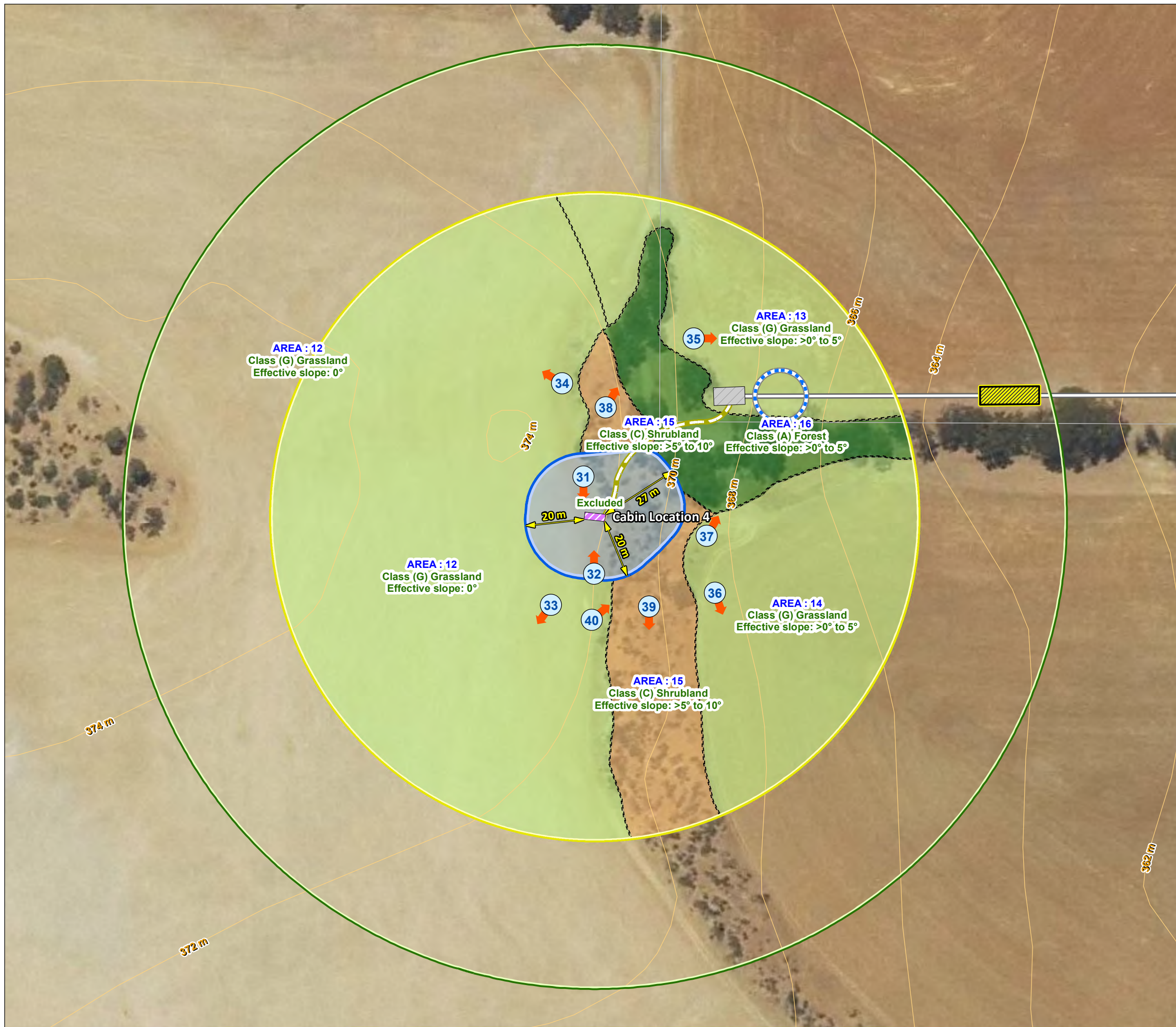

----- **LEGEND** -----

- Subject Site
- Other Lots
- Proposed Building**
- Proposed Cabin
- Carpark
- ↔ Photo & Direction
- Asset Protection**
- Indicative Proposed APZ
- Driveway
- Turnaround (20m Wide)
- Walktrack
- Passing Bay (20m x 6m)
- Vegetation Assessment Area**
- 150m from Subject Site
- 100m from Subject Site
- Classified Vegetation**
- Class (A) Forest
- Class (C) Shrubland
- Class (G) Grassland
- Exclusion 2.2.3.2
- ↔ APZ Distance

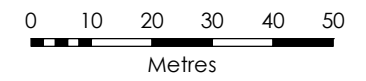

----- **LOCALITY** -----

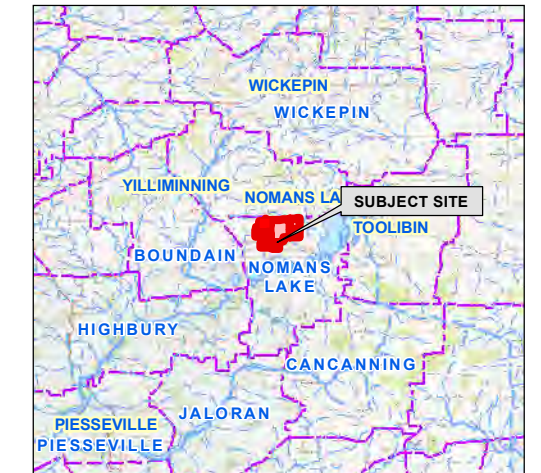

Aerial Imagery : Landgate/SLIP
 Image Date : Dec 2016

Coordinate System: GDA 1994 MGA Zone 50
 Projection: Universal Transverse Mercator Units: Metre
 Map compiled by: Ian Ross 4/05/2021
 Map updated by: Ian 4/05/2021

Figure 3.1.5
**Topography &
 Classified Vegetation**

CABIN LOCATION 5
 Lot 5324 on Plan 118430, Area : 652,865 sq m
 443 Kilpatrick Road,
 NOMANS LAKE 6312
SHIRE OF NARROGIN

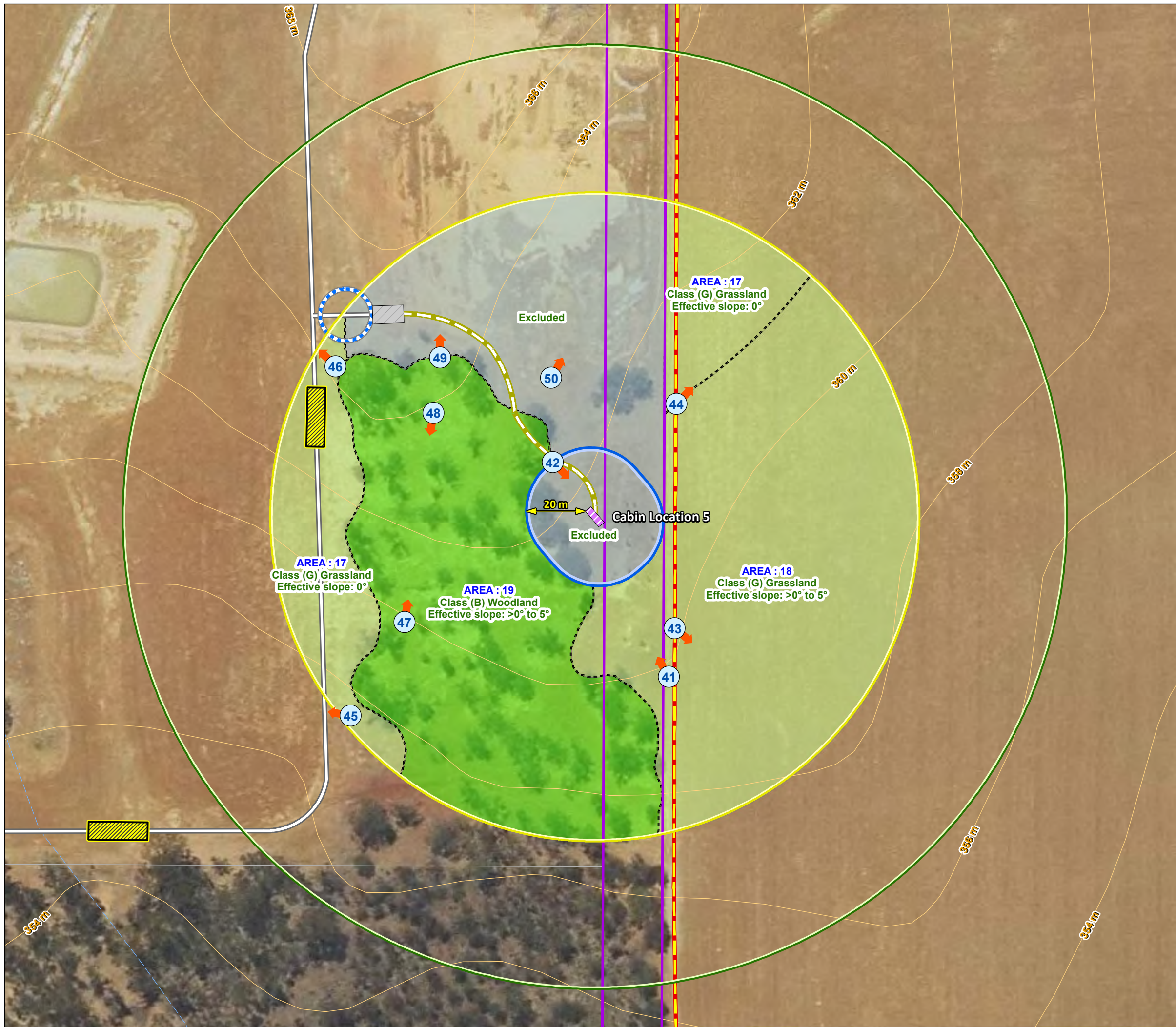

----- **LEGEND** -----

- Subject Site
- Other Lots
- Proposed Building**
- Proposed Cabin
- Carpark
- Photo & Direction
- Asset Protection**
- Indicative Proposed APZ
- Access / Egress**
- Emergency Access
- Driveway
- Turnaround (20m Wide)
- Walktrack
- Passing Bay (20m x 6m)
- Vegetation Assessment Area**
- 150m from Subject Site
- 100m from Subject Site
- Classified Vegetation**
- Class (B) Woodland
- Class (G) Grassland
- Exclusion 2.2.3.2
- APZ Distance

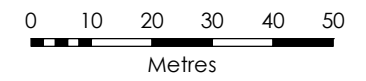

----- **LOCALITY** -----

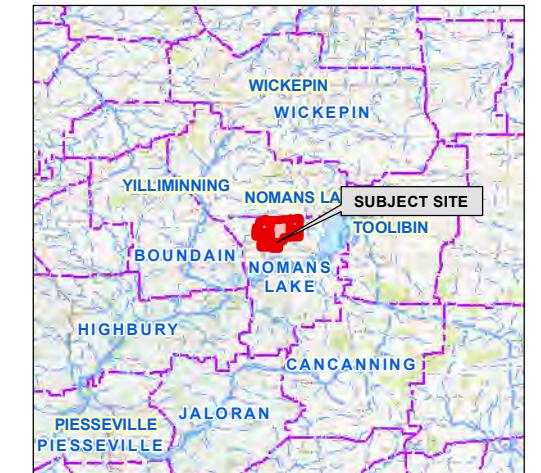

Aerial Imagery : Landgate/SLIP
 Image Date : Dec 2016

Coordinate System: GDA 1994 MGA Zone 50
 Projection: Universal Transverse Mercator Units: Metre
 Map compiled by: Ian Ross 4/05/2021
 Map dated by: Ian 4/05/2021

3.1.3 Vegetation Separation Distance

The vegetation separation distance is the horizontal distance measured from the relevant parts of an existing building or a future building's planned location (within a lot), to the determined edge of an area of classified vegetation.

This separation distance applied to determining a Bushfire Attack Level (BAL) can be either:

- The measured distance – for which the location of the building relative to the edge of classified vegetation must be known. This will result in single determined BAL that will apply to a building. (The measured distance is a required calculation input); or
- A calculated minimum and maximum distance (range) that will correspond to each individual BAL. The calculated distances provide an indicative (or achievable) BAL for which the determined BAL will be dependent on the known location of the building relative to the edge of classified vegetation.

The calculated range of distances corresponding to each BAL can be presented in different formats (tables or a BAL contour map), dependent on the form of information that is most appropriate for the proposed development/use. These distance ranges corresponding to BAL(s) will be presented in Section 3.2: 'Assessment Output'.

For the proposed land use, the applicable vegetation separation distances will be presented within the Bushfire Management Plan in this location:

In Section 3.2 'Assessment Output' as a table containing the calculated ranges of distance corresponding to each BAL and illustrated as a BAL Contour Map.

3.2 Assessment Output

UNDERSTANDING THE RESULTS OF THE BUSHFIRE IMPACT ASSESSMENT

Bushfire Attack Levels (BALs) – Their Application in the Building Environment is Different to the Planning Environment

In the building environment, a **determined BAL** is required for the proposed construction at the building application stage. This is to inform approval considerations and establish the bushfire construction standards that are to apply. An indicative BAL is not acceptable for a building application.

In the planning environment, through the application of SPP 3.7 and associated Guidelines, the deemed to satisfy requirement for a proposed 'development site' or sites (defined by the LPS Amendment Regulations 2015 as "that part of a lot on which a building that is the subject of development stands or is to be constructed"), is that a BAL-29 or lower rating can be achieved once all works associated with the proposal are completed. For planning approval purposes, an **indicative BAL** can provide the required information.

Determined Bushfire Attack Level

A determined BAL is to apply to an existing building or the 'development site' on which the building is to be constructed and not to a lot or building envelope. Its purpose is to state the potential radiant heat flux to which the building will be exposed, thereby determining the construction standard to be applied.

A determined BAL cannot be given for a future building whose design and position on the lot are unknown or the vegetation separation distance has not been established. It is not until these variables have been fixed that a determined BAL can be stated, and a BAL Certificate can be issued.

The one exception is when a building **of any dimension** can be **positioned anywhere** on a proposed lot (within R-Code building setbacks) or within a defined building envelope, and always remain subject to the same BAL, regardless of the retention of any existing classified vegetation either onsite or offsite.

Indicative Bushfire Attack Level

If a BAL is not able to achieve 'determined' status it will be an indicative BAL. It indicates the BAL that can be achieved by the proposed development/use. However, it is conditional upon an assessment variable(s) being confirmed at a later stage (e.g. the building location is established/changed, or vegetation is removed to establish the vegetation separation distance).

A BAL certificate cannot be issued for an indicative BAL – unless that BAL cannot vary (refer to 'Determined BAL' above).

In table form, a single or a range of indicative BAL(s) may be presented. If a single indicative BAL is stated for a defined area (i.e. the lot or building envelope), this will be the highest indicative BAL impacting the defined area.

In BAL contour map form (refer to Section 3.2.1), the illustrated BAL contours visually identify areas of land for which if any part of an existing or proposed building is located on that land and within the BAL contours, then the highest BAL affecting that building (or part of the land on which the building will be constructed), will be the indicative BAL that is to apply.

The BAL can only become a determined BAL once the actual location of that building on the land is known and/or the required minimum vegetation separation distance corresponding to the relevant BAL contour is established (refer to Table 3.3).

3.2.1 Bushfire Attack Level Results - BAL Contour Map Format

INTERPRETATION OF THE BUSHFIRE ATTACK LEVEL (BAL) CONTOUR MAP

The contour map will present different coloured contour intervals extending from the areas of classified bushfire prone vegetation. These represent the different bushfire attack levels that will exist at varying distances away from the classified vegetation in the event of a bushfire in that vegetation.

The areas of classified vegetation are those that will remain as the intended end state of the subject development once earthworks, clearing and/or landscaping and re-vegetation have been completed (or each stage completed).

Each bushfire attack level corresponds to a set range of radiant heat flux that is generated by a bushfire. That range is defined by the AS 3959:2018 BAL determination methodology.

The width of each shaded BAL contour is a diagrammatic representation of the separation distances from the classified vegetation that correspond to each BAL for each separately identified area of classified vegetation. They have been calculated by the application of the unique site variables including vegetation types and structure, ground slope and applied fire weather.

Refer to Section 3.2 'Understanding the Results of the Bushfire Impact Assessment' for the explanation of how BAL(s) for buildings will be assessed from the BAL Contour Map).

Construction of the BAL Contours

Table 3.2: Vegetation separation distances applied to construct the BAL contours.

BAL CONTOUR MAP – APPLIED VEGETATION SEPARATION DISTANCES								
Derived from the Application of Method 1 BAL Determination Methodology (AS 3959:2018 Section 2, Table 2.5) ¹								
Vegetation Area	Vegetation Classification	Effective Slope (degree range)	BAL and Corresponding Separation Distance (m)					
			BAL-FZ	BAL-40	BAL-29	BAL-19	BAL12.5	BAL-LOW
1	Class G Grassland	upslope or flat	<6	6-<8	8-<12	12-<17	17-<50	>50
2	Class G Grassland	downslope >0-5	<7	7-<9	9-<14	14-<20	20-<50	>50
3	Class D Scrub	downslope >0-5	<11	11-<15	15-<22	22-<31	31-<100	>100
4	Class D Scrub	upslope or flat	<10	10-<13	13-<19	19-<27	27-<100	>100
5	Class D Scrub	downslope >0-5	<11	11-<15	15-<22	22-<31	31-<100	>100
6	Class G Grassland	upslope or flat	<6	6-<8	8-<12	12-<17	17-<50	>50
7	Class D Scrub	upslope or flat	<10	10-<13	13-<19	19-<27	27-<100	>100
8	Class A Forest	upslope or flat	<16	16-<21	21-<31	31-<42	42-<100	>100
9	Class G Grassland	upslope or flat	<6	6-<8	8-<12	12-<17	17-<50	>50
10	Class D Scrub	upslope or flat	<10	10-<13	13-<19	19-<27	27-<100	>100
11	Class A Forest	upslope or flat	<16	16-<21	21-<31	31-<42	42-<100	>100
12	Class G Grassland	upslope or flat	<6	6-<8	8-<12	12-<17	17-<50	>50
13	Class G Grassland	downslope >0-5	<7	7-<9	9-<14	14-<20	20-<50	>50
14	Class G Grassland	downslope >0-5	<7	7-<9	9-<14	14-<20	20-<50	>50
15	Class C Shrubland	downslope >5-10	<8	8-<11	11-<17	17-<25	25-<100	>100
16	Class A Forest	downslope >0-5	<20	20-<27	27-<37	37-<50	50-<100	>100
17	Class G Grassland	upslope or flat	<6	6-<8	8-<12	12-<17	17-<50	>50
18	Class G Grassland	downslope >0-5	<7	7-<9	9-<14	14-<20	20-<50	>50
19	Class B Woodland	downslope >0-5	<13	13-<17	17-<25	25-<35	35-<100	>100

Note¹ All the assessment inputs applied are presented in Section 3.1

Figure 3.2.1

BAL Contour Map

CABIN LOCATION 1

Lot 5324 on Plan 118430, Area : 652,865 sq m
 443 Kilpatrick Road,
 NOMANS LAKE 6312
SHIRE OF NARROGIN

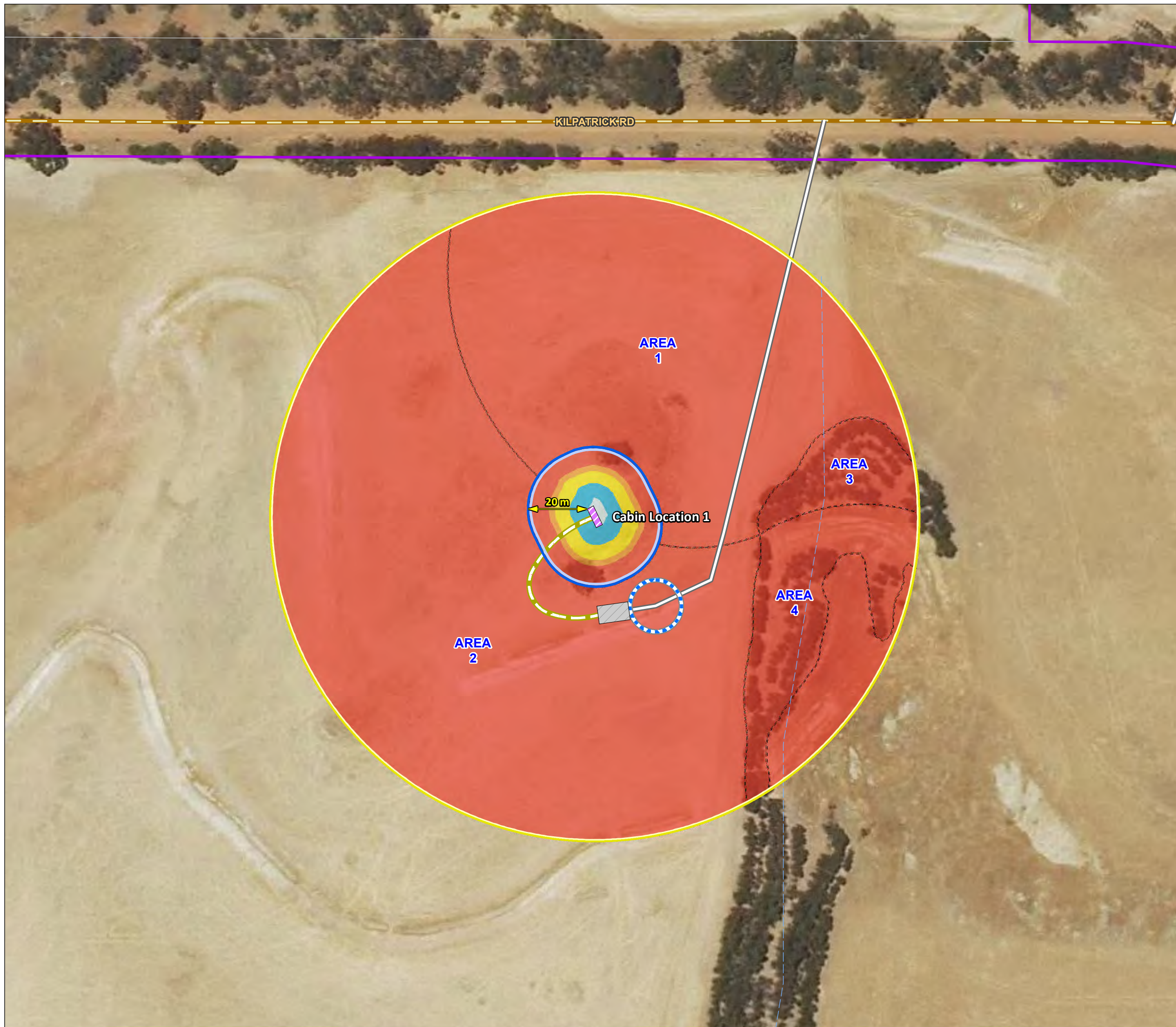

----- LEGEND -----

- Subject Site
- Other Lots
- Proposed Building**
- Proposed Cabin
- Carpark
- Asset Protection**
- Indicative Proposed APZ
- Driveway
- Turnaround (20m Wide)
- Walktrack
- Vegetation Assessment Area**
- 100m from Subject Site
- Classified Vegetation Boundary
- Indicative Bushfire Attack Levels**
- BAL FZ
- BAL 40
- BAL 29
- BAL 19
- BAL 12.5
- APZ Distance

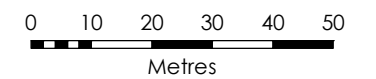

----- LOCALITY -----

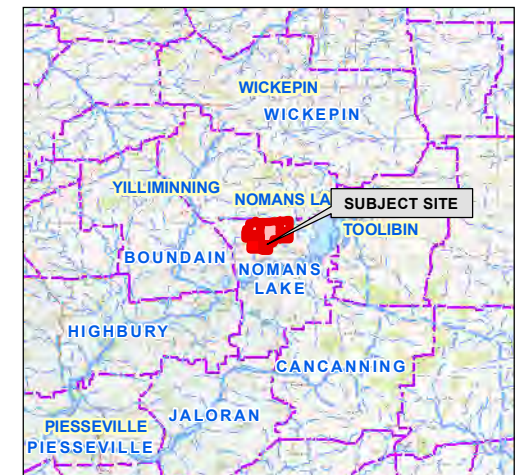

Aerial Imagery : Landgate/SLIP
 Image Date : Dec 2016



Coordinate System: GDA 1994 MGA Zone 50
 Projection: Universal Transverse Mercator Units: Metre
 Map compiled by: Ian Ross 4/05/2021
 Map updated by: Ian 4/05/2021

Figure 3.2.2

BAL Contour Map

CABIN LOCATION 2

Lot 5324 on Plan 118430, Area : 652,865 sq m
 443 Kilpatrick Road,
 NOMANS LAKE 6312
SHIRE OF NARROGIN

----- LEGEND -----

- Subject Site
- Other Lots
- Proposed Building**
- Proposed Cabin
- Carpark
- Asset Protection**
- Indicative Proposed APZ
- Access / Egress**
- Emergency Access
- Driveway
- Turnaround (20m Wide)
- Walktrack
- Passing Bay (20m x 6m)
- Vegetation Assessment Area**
- 100m from Subject Site
- Classified Vegetation Boundary
- Indicative Bushfire Attack Levels**
- BAL FZ
- BAL 40
- BAL 29
- BAL 19
- BAL 12.5
- APZ Distance

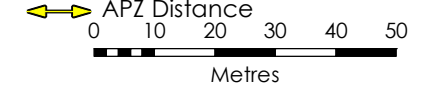

----- LOCALITY -----

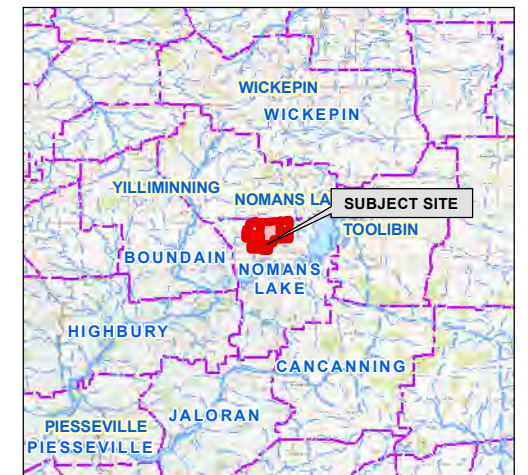

Aerial Imagery : Landgate/SLIP
 Image Date : Dec 2016



Coordinate System: GDA 1994 MGA Zone 50
 Projection: Universal Transverse Mercator Units: Metre
 Map compiled by: Ian Ross 4/05/2021
 Map updated by: Ian 4/05/2021

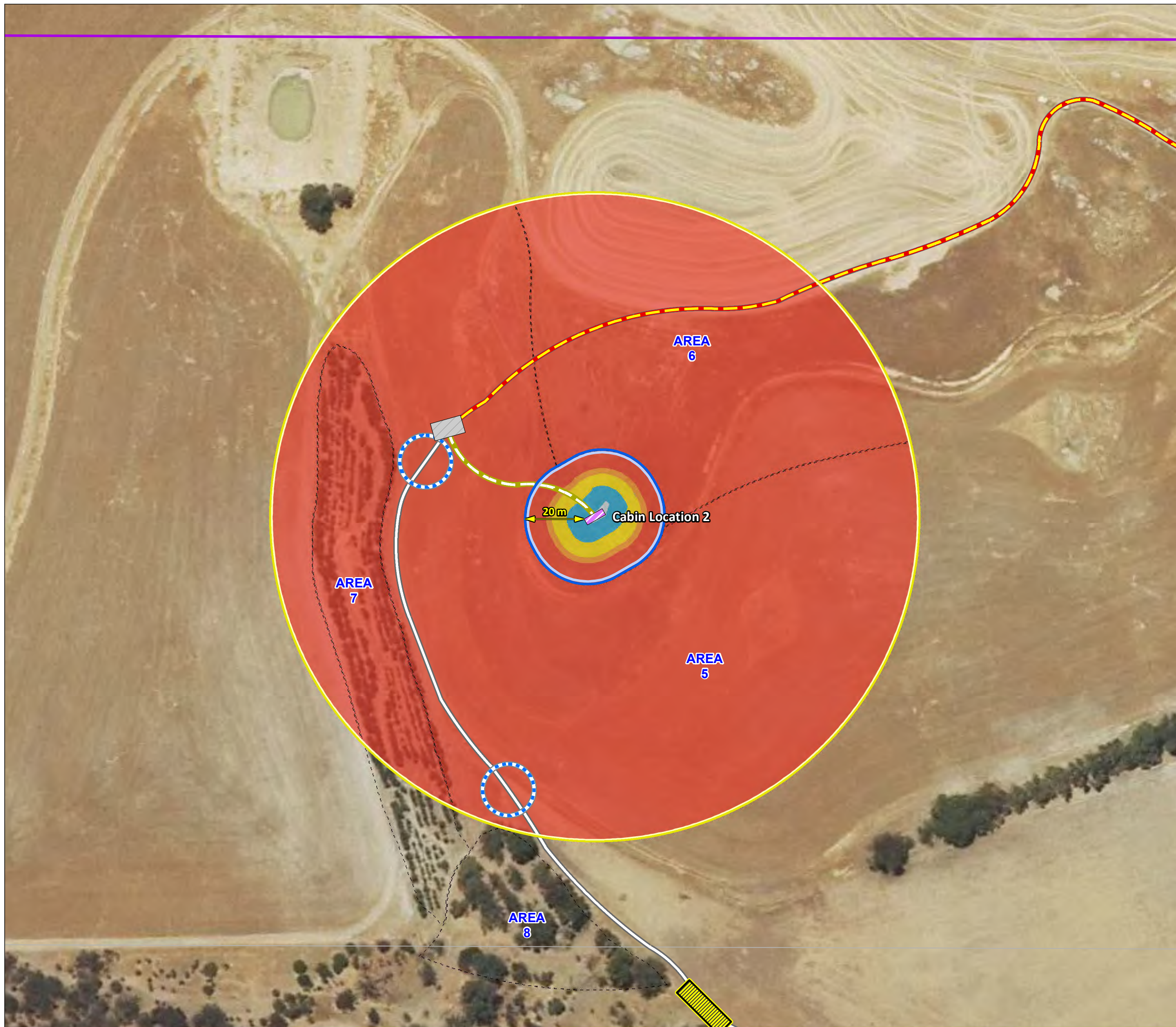
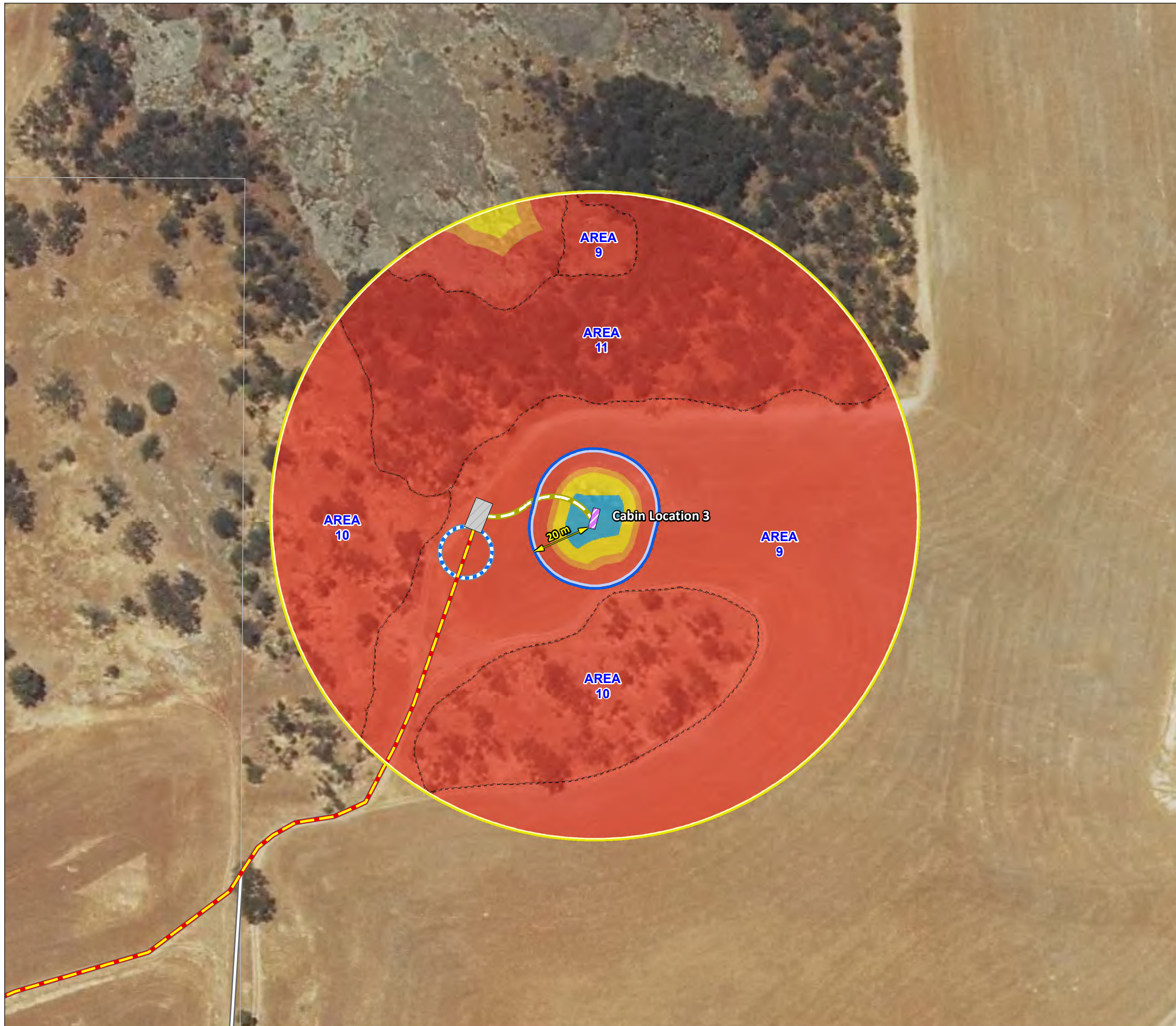

Figure 3.2.3

BAL Contour Map

CABIN LOCATION 3

Lot 5324 on Plan 118430, Area : 652,865 sq m
 443 Kilpatrick Road,
 NOMANS LAKE 6312
SHIRE OF NARROGIN



----- LEGEND -----

- Subject Site
- Other Lots
- Proposed Building**
- Proposed Cabin
- Carpark
- Asset Protection**
- Indicative Proposed APZ
- Access / Egress**
- Emergency Access
- Driveway
- Turnaround (20m Wide)
- Walktrack
- Vegetation Assessment Area**
- 100m from Subject Site
- Classified Vegetation Boundary
- Indicative Bushfire Attack Levels**
- BAL FZ
- BAL 40
- BAL 29
- BAL 19
- BAL 12.5
- APZ Distance

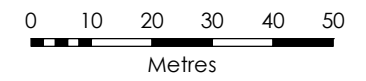

----- LOCALITY -----

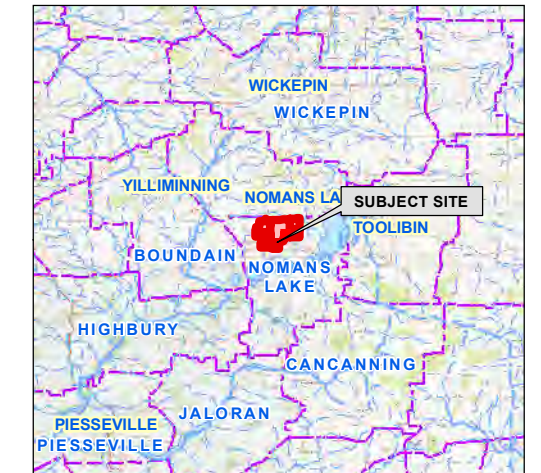

Aerial Imagery : Landgate/SLIP
 Image Date : Dec 2016

Coordinate System: GDA 1994 MGA Zone 50
 Projection: Universal Transverse Mercator Units: Metre
 Map compiled by: Ian Ross 4/05/2021
 Map updated by: Ian 4/05/2021

Figure 3.2.4

BAL Contour Map

CABIN LOCATION 4

Lot 5324 on Plan 118430, Area : 652,865 sq m
 443 Kilpatrick Road,
 NOMANS LAKE 6312
SHIRE OF NARROGIN

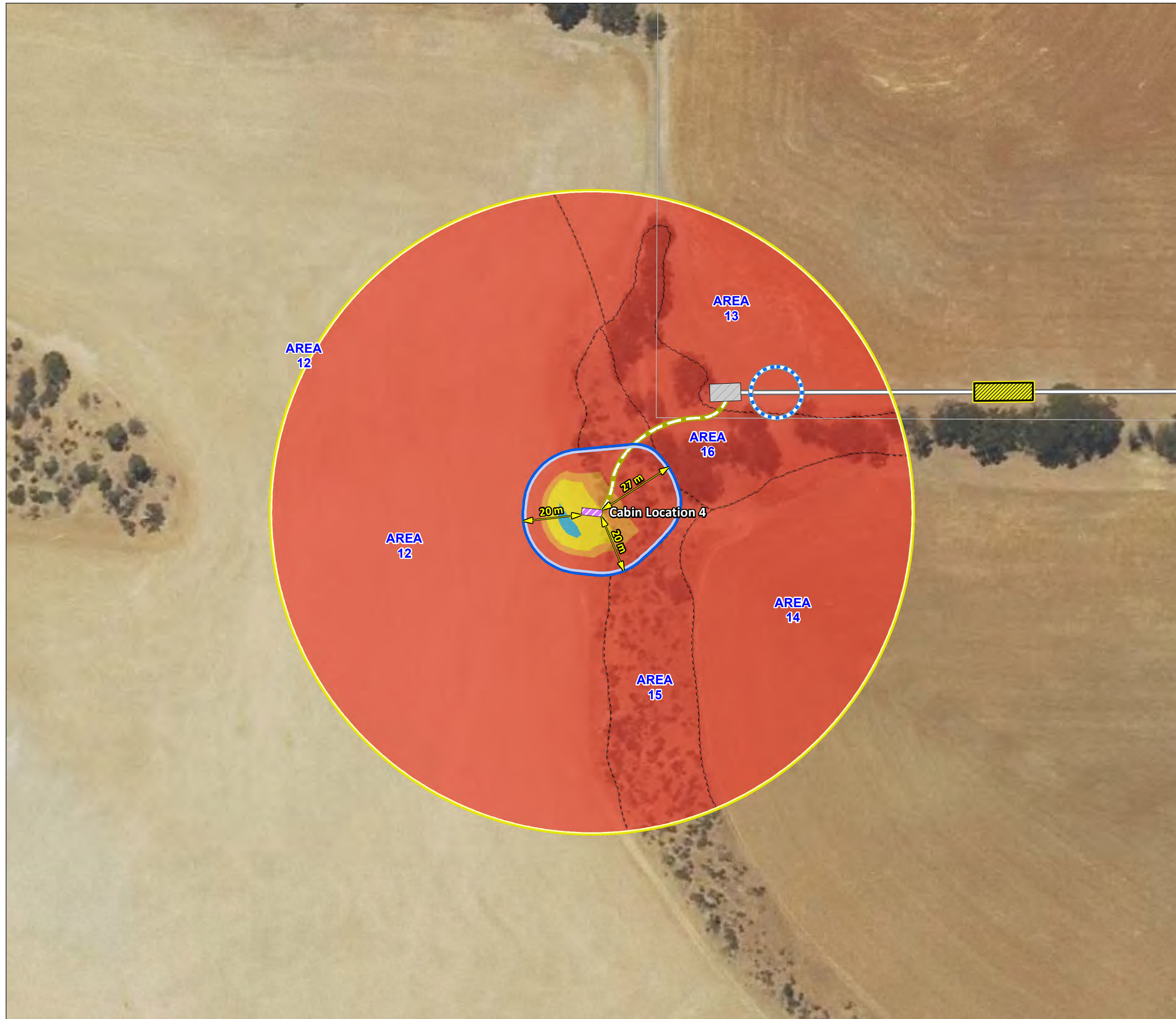

----- LEGEND -----

- Subject Site
- Other Lots
- Proposed Building**
- Proposed Cabin
- Carpark
- Asset Protection**
- Indicative Proposed APZ
- Driveway
- Turnaround (20m Wide)
- Walktrack
- Passing Bay (20m x 6m)
- Vegetation Assessment Area**
- 100m from Subject Site
- Classified Vegetation Boundary
- Indicative Bushfire Attack Levels**
- BAL FZ
- BAL 40
- BAL 29
- BAL 19
- BAL 12.5
- BAL LOW
- APZ Distance

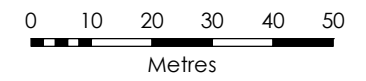

----- LOCALITY -----

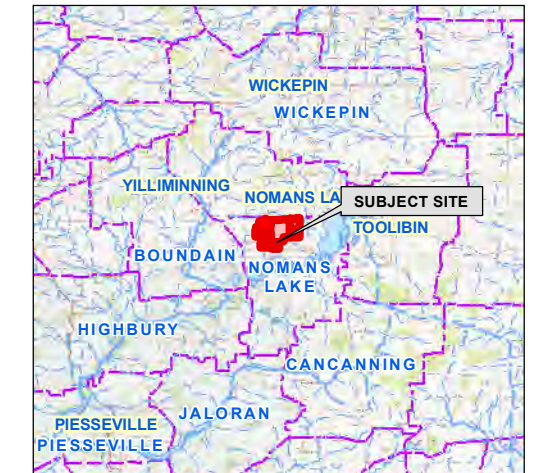

Aerial Imagery : Landgate/SLIP
 Image Date : Dec 2016

Coordinate System: GDA 1994 MGA Zone 50
 Projection: Universal Transverse Mercator Units: Metre
 Map compiled by: Ian Ross 4/05/2021
 Map updated by: Ian 4/05/2021

Figure 3.2.5

BAL Contour Map

CABIN LOCATION 5

Lot 5324 on Plan 118430, Area : 652,865 sq m
 443 Kilpatrick Road,
 NOMANS LAKE 6312
SHIRE OF NARROGIN

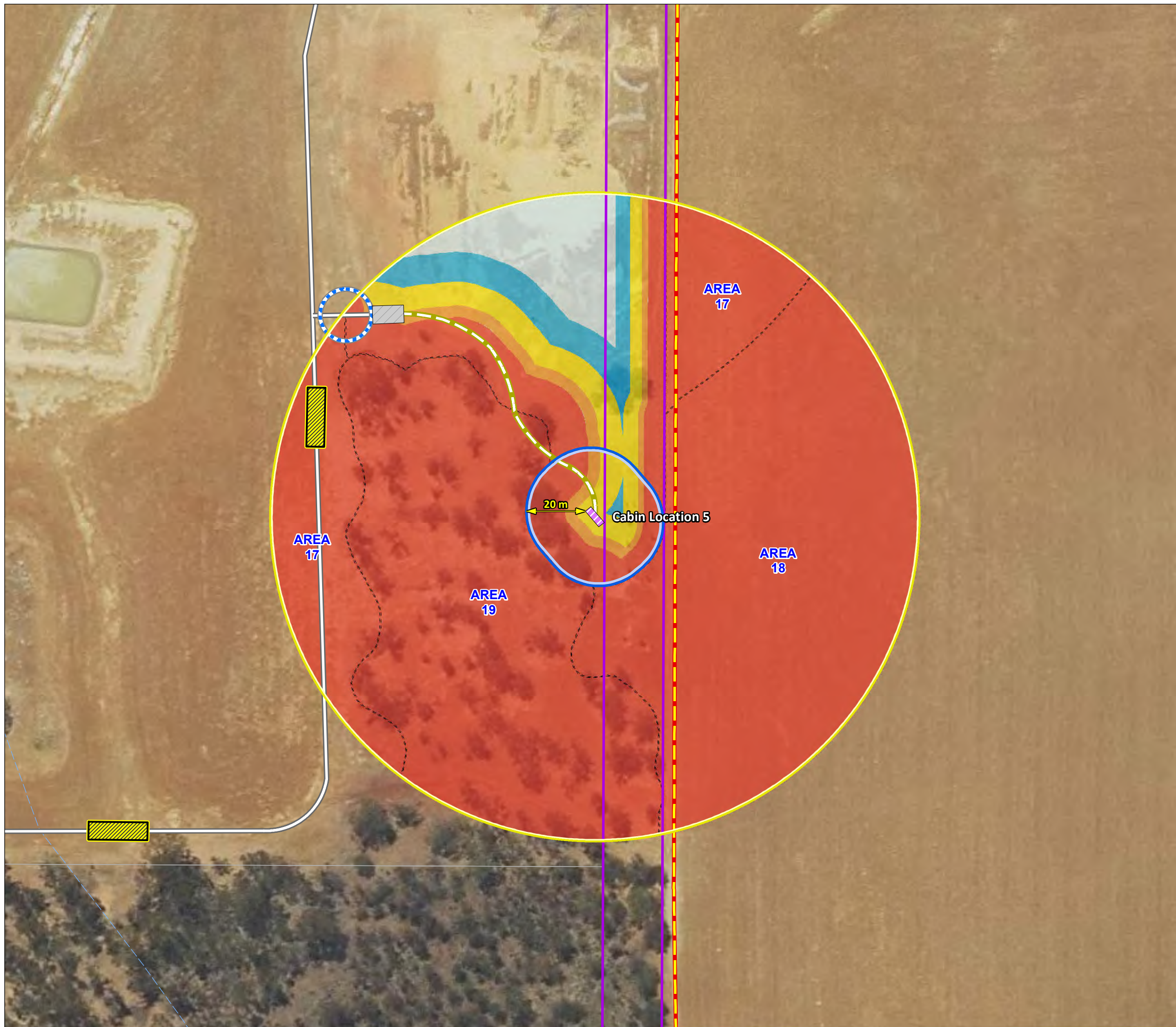

----- LEGEND -----

- Subject Site
- Other Lots
- Proposed Building**
- Proposed Cabin
- Carpark
- Asset Protection**
- Indicative Proposed APZ
- Access / Egress**
- Emergency Access
- Driveway
- Turnaround (20m Wide)
- Walktrack
- Passing Bay (20m x 6m)
- Vegetation Assessment Area**
- 100m from Subject Site
- Classified Vegetation Boundary
- Indicative Bushfire Attack Levels**
- BAL FZ
- BAL 40
- BAL 29
- BAL 19
- BAL 12.5
- APZ Distance



----- LOCALITY -----

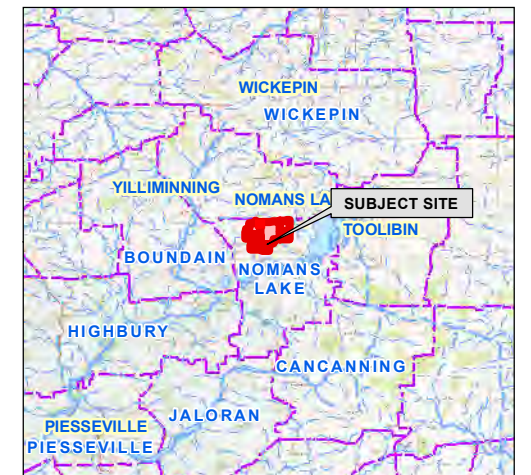

Aerial Imagery : Landgate/SLIP
 Image Date : Dec 2016

Coordinate System: GDA 1994 MGA Zone 50
 Projection: Universal Transverse Mercator Units: Metre
 Map compiled by: Ian Ross 4/05/2021
 Map updated by: Ian 4/05/2021

3.2.2 Bushfire Attack Level Results - Derived from The BAL Contour Map

Table 3.3: Indicative BAL(s) for proposed Tiny Cabins.

INDICATIVE BAL(S) FOR PROPOSED TINY CABINS					
<p>The determined BAL for the subject building works and/or use (or the Indicative BAL if the conditions are to be met and it is applied), establishes the bushfire construction requirements that will be applied to the proposed building works and/or use.</p> <p>Consequently, it is important that the required minimum standards and dimensions of the APZ are maintained into the future to ensure the proposed building works or use remains subject to the BAL to which the building is constructed (so that it will continue to better withstand the potential bushfire impact). The minimum dimensions (vegetation separation distances) are stated below. These may differ from the distances that currently exist (i.e. existing distances may exceed the minimum required).</p> <p>The minimum distances may also differ from those established by the Firebreak and Fuel Hazard Reduction Notice issued by the local government. The required dimensions of the APZ's are depicted on the BAL Contour Maps Figures 3.2.1 to 3.2.5 included in this report.</p>					
MINIMUM VEGETATION SEPARATION DISTANCES REQUIRED TO ENSURE THE BUILDING WORKS AND/OR USE REMAIN SUBJECT TO THE ASSESSED BAL (DETERMINED OR INDICATIVE)					
Proposed Building (Tiny Cabins)	Vegetation Area	Vegetation Classification	Applied (degree range)	Assessed Bushfire Attack Level	Minimum Required Vegetation Separation Distance (metres)
Cabins	1	Class G Grassland	Upslope or flat 0	The Indicative BAL BAL-29	8
	2	Class G Grassland	Downslope >0-5		9
	3	Class D Scrub	Downslope >0-5		15
	4	Class D Scrub	Upslope or flat 0		13
	5	Class D Scrub	Downslope >0-5		15
	6	Class G Grassland	Upslope or flat 0		8
	7	Class D Scrub	Upslope or flat 0		13
	8	Class A Forest	Upslope or flat 0		21
	9	Class G Grassland	Upslope or flat 0		8
	10	Class D Scrub	Upslope or flat 0		13
	11	Class A Forest	Upslope or flat 0		21
	12	Class G Grassland	Upslope or flat 0		8
	13	Class G Grassland	Upslope or flat 0		8
	14	Class G Grassland	Downslope >0-5		9
	15	Class C Shrubland	Downslope >5-10		11
	16	Class A Forest	Downslope >0-5		27
	17	Class G Grassland	Upslope or flat 0		8
	18	Class G Grassland	Downslope >0-5		9
	19	Class B Woodland	Downslope >0-5		17

4 IDENTIFICATION OF BUSHFIRE HAZARD ISSUES

Western Australia experiences an extended period of dry weather in the summer period between November and April. Bushfire fuels built up in eucalypt woodland and forest combined with wind and dry, hot conditions, which support bushfires are normal and common during summer months. These conditions must be assumed to always exist during this period.

The key bushfire hazard issues for the Tiny Cabin development site are summarized as follows:

Vegetation: The subject site is generally undulating cropping and pasture land. Mixed vegetation types are evident throughout the extensive area of farmland with pockets of forest, woodland and scrub remnant vegetation and retained vegetation, including along water course areas, with predominantly manageable cropping/pasture vegetation around the Tiny Cabins. Native vegetation and the landscape in the development area is conducive to bushfire.

Asset Protection Zones: Asset Protection Zones (APZs) can and will be established within the development area around the Tiny Cabins to reduce the bushfire impact and radiant heat on those structures and provide a defendable area where bushfire conditions are favorable to suppression activities.

Access & Egress: The proposed development sites for the Tiny Cabins are located greater than 50m from the public road, Kilpatrick Road to the south and Yilliminning Road to the north. The internal private driveway to the proposed carpark areas of each Tiny Cabin will comply with the technical requirements of the Guidelines for Planning in Bushfire prone Areas, including the provision of turn-around areas.

Water: The intention is to actively defend property and infrastructure where conditions are tenable to do so and provision of a minimum 50,000 litres static water supply dedicated for firefighting purposes will be maintained on site, in addition to any requirements for potable water requirements for the Tiny Cabins. Water can also be drafted from the large dams that have permanent water all year round, a natural hard surface maintained access for vehicles to access the dams within 2.5m of the dam edge for drafting purposes. The identified water supplies are not utilised for potable domestic water supply to the dwellings on the property.

Implementation mechanisms to support the BMP: The proposed development is considered a Vulnerable Land Use and a Bushfire Emergency Plan is required, to improve the preparedness of short-term accommodation occupants by identifying steps to be followed before, during and after a bushfire event. The BEP will be provided as a separate document to the BMP, after subsequent consideration of the scale and merit of the proposed development by the Shire of Narrogin.

5 ASSESSMENT AGAINST THE ACCEPTABLE SOLUTIONS (POLICY MEASURES) ESTABLISHED BY THE 'TOURISM LAND USE' POSITION STATEMENT

For a proposal (future application) that is a 'Tourism Land Use' to be considered compliant with SPP 3.7, it must satisfy the requirements established by the *Position Statement: Tourism land uses in bushfire prone areas WAPC October 2019*. The position statement establishes 'tourism land use specific' policy objectives and measures and establishes a set of elements and corresponding acceptable solutions (policy measures) against which a tourism proposal is to be assessed (replacing the bushfire protection criteria established by the Guidelines). Compliance can be achieved by either:

- Meeting all applicable acceptable solutions corresponding to each element (i.e. the minimum bushfire protection measures that are deemed to satisfy planning requirements); or
- Where an acceptable solution cannot be met, conduct a risk based assessment and if necessary, apply additional and/or contingency bushfire protection measures to reduce the risk to an acceptable level (as relevant to the land use and its scale and location).

5.1 Local Government Variations to Apply

Local governments may add to or modify the acceptable solutions of the Bushfire Protection Criteria (BPC) and/or apply technical requirements that vary from those specified in the Guidelines for Planning in Bushfire Prone Areas (WAPC). In such instances, this land use will be assessed against these variations and/or any specific local government technical requirements for emergency access and water. Refer to Appendices 2 and 3 for relevant technical requirements.

Will local or regional variations (endorsed by WAPC / DFES) to the applicable acceptable solutions established by the <i>Guidelines</i> or the <i>Position Statement: Tourism land uses in bushfire prone areas WAPC October 2019</i> , apply to this Proposal?	N/A
---	-----

For some tourism land uses a variation to the acceptable solutions may be applicable and/or specific LG technical requirements for emergency access and water may be applied. The Bushfire Protection Criteria assessment applying these variations will be included in the appendices if the LG require them to be in the BMP rather than just being referred to.

The Armstrong Farms property currently requires adhering to the Shire of Narrogin annual Firebreak and Fuel Hazard Reduction Notice requirements as minimum bushfire protection criteria.

5.2 Summary of Assessment Against the Acceptable Solutions for Tourism Land Use

SUMMARISED OUTCOME OF THE ASSESSMENT AGAINST THE ACCEPTABLE SOLUTIONS (POLICY MEASURES) OF THE TOURISM LAND USE POSITION STATEMENT			
Element (Table 1: Tourism Land Uses - 'Tourism Position Statement')	Basis of Achieving the Intent of the Bushfire Protection Measures Established in Table 1 of the Position Statement: Tourism land uses in bushfire prone areas (WAPC October 2019) and Compliance with SPP 3.7		
	All Applicable Acceptable Solutions (Policy Measures) Are or Can be Fully Met	The Site is Supported by a Risk-Based Assessment (in a form that reflects the nature and scale of the landuse) and The Application of Additional Bushfire Protection Measures as Necessary	
		Bushfire Risk Assessment and Treatment Plan (refer to separate document)	Basic Risk Assessment (refer to Addendum 1)
1. Siting and Design	✓		
2. Vehicular Access	✓		
3. Provision of Water	✓		
<p>Note: The Site has been assessed:</p> <ol style="list-style-type: none"> Against the requirements established by Table 1 of the <i>Position Statement: Tourism land uses in bushfire prone areas (WAPC October 2019)</i> Against the requirements established in Appendix 4 of the <i>Guidelines for Planning in Bushfire Prone Areas, WAPC 2017 v1.3 (Guidelines)</i> but excluding the Bushfire Protection Criteria unless referenced by the above 'Position Statement'. The Guidelines are found at https://www.planning.wa.gov.au/8194.aspx; and Applying the interpretation guidance provided in <i>Position Statement: Planning in bushfire prone areas – Demonstrating Element 1: Location and Element 2: Siting and design (WAPC Nov 2019)</i> – to the extent guidance regarding Element 2 may be applied to a development application. 			

5.3 Assessment Detail

Element 1 (Tourism Land Use): Siting and Design of Development				
Tourism Type: Caravan Park – Includes Camping Ground				
Intent: To provide bushfire protection for tourism uses relevant to the characteristics of the occupants and/or surrounding community to preserve life and reduce the impact of bushfire on property and infrastructure.				
Compliance: How the proposed development achieves the intent of Element 1:		By fully meeting all applicable acceptable solutions established by Table 1 of Position Statement: Tourism land uses in bushfire prone areas (WAPC October 2019)		
ASSESSMENT (COMPLIANCE) STATEMENTS				
For each applicable acceptable solution, the following statements present the results of the assessment of the proposed development/use against the requirements established by the <i>Position Statement: Tourism land uses in bushfire prone areas (WAPC October 2019)</i> .				
Acceptable Solution (Policy Measure): 1.1: Siting and design to reduce levels of radiant heat, smoke and ember attack. Consideration should be given to:				
<ul style="list-style-type: none"> The provision of an APZ to achieve 29kW/m² around the campground facilities, which may include the office, manager's residence, camp kitchen and shower/laundry. Clustering of Campsites and securing an APZ around the entire development or providing an APZ to separate the site from the potential adjoining hazard. Where there is no bushfire construction standard (i.e. tents and caravans and some eco tents) and the loss of these structures is identified in a risk assessment as a 'tolerable' risk, then no APZ is required and subject to a risk assessment, these structures may be located in areas of BAL-40 or BAL-FZ. 				
For additional details refer to Section 5.4 'Additional Bushfire Protection Measures and Section 6 'Responsibilities for Implementation and Maintenance', of this BMP. The construction technical requirements established by the Guidelines and/or the local government can and will be complied with. These requirements are set out in Appendix 2.				
THE ASSESSMENT				
The future cabins on the Armstrong Farms property for the proposed development can be surrounded by an APZ that will ensure the potential radiant heat impact of a bushfire does not exceed 29 kW/m ² (BAL-29). The required APZ specifications of width, location and management can be achieved.				
APZ Width: The required APZ dimensions to ensure buildings are subject to a maximum BAL of BAL-29 (measured from any external wall or supporting post or column to the edge of the classified vegetation), has been determined in Section 3.2 of this BMP and are:				
MINIMUM VEGETATION SEPARATION DISTANCES REQUIRED TO ENSURE THE BUILDING WORKS AND/OR USE REMAIN SUBJECT TO THE ASSESSED BAL (DETERMINED OR INDICATIVE)				
Proposed Building (Tiny Cabins)	Vegetation Classification	Applied (degree range)	Assessed Bushfire Attack Level	Minimum Required Vegetation Separation Distance (metres)
All Cabins	Class G Grassland	Upslope or flat 0	The Indicative BAL	8
	Class G Grassland	Downslope >0-5	BAL-29	9

Element 1 (Tourism Land Use): Siting and Design of Development

All Cabins	Class D Scrub	Upslope or flat 0	The Indicative BAL BAL-29	13
	Class D Scrub	Downslope >0-5		15
	Class C Shrubland	Downslope >5-10		11
	Class B Woodland	Downslope >0-5		17
	Class A Forest	Upslope or flat 0		21
	Class A Forest	Downslope >0-5		27

Comments: A minimum 20 m APZ will be implemented for each cabin enabling a BAL-29 rating for the Cabin.

The land on which the APZ's will exist is entirely within the existing lot (i.e. under management control of the owner).

APZ Location: Asset protection zones of the widths stated above can be contained solely within the boundaries of the lot (refer to Figures 3.2.1 to 3.2.5 for illustrative maps). Onsite vegetation will be required to be modified/removed, the authority for which will need to be received from the local government, if applicable.

APZ Management: All vegetation that will require modification/removal and future management is onsite and therefore under the control of the landowner.

Retained vegetation will be managed in accordance with the technical requirements established by the Schedule 1: 'Standards for Asset Protection Zones (Guidelines)'. The APZ specifications are also detailed in Appendix 1.

THE APZ – REQUIRED DIMENSIONS TO SATISFY FUTURE BUILDING (AND ONGOING MANAGEMENT)

It is important for the landowner to be aware that the APZ dimensions that will be required to be physically established and maintained on each lot surrounding relevant future buildings, may be different to those stated above for the BAL-29 APZ - which is the minimum dimension a planning proposal needs to show can be established to comply with SPP 3.7.

The actual APZ dimensions to be physically established and maintained, will be based on which of the following establishes the larger APZ dimension:

- The dimensions corresponding to the determined BAL of a building (refer to Section 3.2 for explanation of the 'planning' versus 'building' requirements and 'indicative' versus 'determined' BAL); or
- The APZ dimensions established by the local government's Firebreak Notice.

If the dimensions of the APZ that are to be established are known at this time, they will be stated below.

Element 1 (Tourism Land Use): Siting and Design of Development

For the proposed development, the cabins are constructed to BAL-29 standards. The APZ corresponding to a BAL-29 rating will be developed around each cabin, to lessen the impact on the cabin where bushfire conditions are conducive to extinguishment operations and resources are available. The determined minimum dimensions of the APZ to achieve a BAL-29 based on proximity to the differing vegetation types on site are indicated in the following table:

The APZ Dimensions to be Established and Maintained Determined BAL for the Proposed Development/Use is BAL-29	
Applicable to Following Building(s): Tiny Cabins – All Cabins	Asset Protection Zone Minimum 20 metres or greater where the corresponding BAL to Forest vegetation type requires increased separation Minimum 27m.

The responsibilities created (in Section 6) to establish/maintain an APZ states this requirement and notes the potential requirements of the firebreak notice.

Acceptable Solution (Policy Measure): 1.2: Where a building is to function as an on-site shelter, there must be sufficient separation distance from the predominant bushfire prone vegetation to avoid exposure to a radiant heat flux exceeding 10kW/m² (with an assumed flame temperature of 1200K); or where an open space area is to function as an on-site shelter, there must be sufficient separation distance from the predominant bushfire prone vegetation to avoid exposure to a radiant heat flux exceeding 2kW/m² (with an assumed flame temperature of 1200K).

For this development, no purpose built on-site shelter is provided.

The site facilitates evacuation of occupants should the area be impacted by bushfire and conditions require evacuation to a place/destination of lower threat.

Acceptable Solution (Policy Measure): 1.3: Buildings identified as suitable on-site shelter shall be designed and constructed in accordance with National Construction Code and the ABCB Community Shelter Handbook.

For this development, no purpose built on-site shelter is provided.

The site facilitates evacuation of occupants should the area be impacted by bushfire and conditions require evacuation to a place/destination of lower threat.

Element 2 (Tourism Land Use): Vehicular Access

Tourism Type: Caravan Park – Includes Camping Ground

Intent: To provide bushfire protection for tourism uses relevant to the characteristics of the occupants and/or surrounding community to preserve life and reduce the impact of bushfire on property and infrastructure.

Compliance: How the proposed development achieves the intent of Element 2:

By fully meeting all applicable acceptable solutions established by Table 1 of Position Statement: Tourism land uses in bushfire prone areas (WAPC October 2019)

ASSESSMENT (COMPLIANCE) STATEMENTS

For each applicable acceptable solution, the following statements present the results of the assessment of the proposed development/use against the requirements established by the *Position Statement: Tourism land uses in bushfire prone areas (WAPC October 2019)*.

Acceptable Solution: 2.1: Caravan parks/camping grounds located in residential built-out areas should provide one access route which connects to the public road network and provides safe access and egress.

N/A

Acceptable Solution: 2.2: Caravan parks/camping grounds located outside of residential built-out areas -where vehicular access in two different directions to two different destinations cannot be provided, the BMP should identify the risks and propose bushfire management measures to reduce this risk, which may include on-site shelter and or closure.

Kilpatrick Road and Yilliminning Road provide two-way access to two differing locations via sealed and unsealed sections of public roads that are available to the public and emergency services at all times. These roads services large rural properties outside of higher density residential areas.

Acceptable Solution: 2.3: All roads should be through roads. Dead end roads are not recommended but if unavoidable, or they are existing, they should be no more than 200 metres.

N/A

Acceptable Solution: 2.4: Access routes should achieve the requirements of Table 6 in the *Guidelines for Planning in Bushfire Prone Areas*.

The internal private driveways to the proposed carpark areas for each Tiny Cabin sites will comply with the technical requirements of the Guidelines, including passing bays at required intervals and provision for turn-around area suitable for large fire appliances. Internal access will incorporate signposting along the driveway and at each carpark site detailing the site configuration and egress to the public road. The carpark will be large enough to accommodate the private vehicles plus provide a turnaround area for fire appliances.

For additional details refer to Section 5.4 'Additional Bushfire Protection Measures and Section 6 'Responsibilities for Implementation and Maintenance', of this BMP.

The construction technical requirements established by the Guidelines and/or the local government can and will be complied with. These requirements are set out in Appendix 2.

Element 3 (Tourism Land Use): Provision of Water

Tourism Type: Caravan Park – Includes Camping Ground

Intent: To provide bushfire protection for tourism uses relevant to the characteristics of the occupants and/or surrounding community to preserve life and reduce the impact of bushfire on property and infrastructure.

Compliance: How the proposed development achieves the intent of Element 3:

By fully meeting all applicable acceptable solutions established by Table 1 of Position Statement: Tourism land uses in bushfire prone areas (WAPC October 2019)

ASSESSMENT (COMPLIANCE) STATEMENTS

For each applicable acceptable solution, the following statements present the results of the assessment of the proposed development/use against the requirements established by the *Position Statement: Tourism land uses in bushfire prone areas (WAPC October 2019)*.

Acceptable Solution: 3.1: The development or land use is provided with a reticulated water supply in accordance with the specifications of the relevant water supply authority and/or the local government; or Acceptable Solution 3.2 or 3.3.

N/A

Acceptable Solution: 3.2: Where the intention is to actively defend property and infrastructure, provision of a minimum 10,000 litre static water supply for firefighting purposes per building/structure, in addition to any requirements for potable water; or Acceptable Solution 3.3.

A dedicated water supply for fire-fighting operations for the cabins is implemented. Water supplies are available on site that can be accessed and utilised for fire-fighting within the Armstrong Farms site. Should local fire brigades require additional water, dams are also accessible.

Potable water requirements as specified by the Shire of Narrogin will be implemented for the cabin occupants use.

Acceptable Solution: 3.3: Where the intention is to actively defend property and infrastructure, provision of a minimum 50,000 litre static water supply for firefighting purposes per 25 buildings/structures, to the satisfaction of the local government.

A minimum 50,000 litres of water is dedicated for fire-fighting purposes in the immediate area, utilising an existing static water tanks, which are located at the Armstrong Farms storage shed/workshop. This tank is not utilised for potable domestic water supply to the dwellings. The location of the tanks can achieve a BAL-29 Asset Protection Zone area around the tanks (Refer Section 6 for water tank APZ distances).

The cabin locations are within a two kilometre radius of the tank site, and enables a 2.4 appliance to achieve a 20 minute turn-around time at legal road speeds.

Acceptable Solution: 3.4: Dedicated water supplies shall be non-combustible (or suitably shielded) and located such that fire services can readily gain access to appropriate fittings and connect fire fighting vehicles to dedicated water supplies in a safe manner.

An existing static water tank located at the existing shed, will incorporate fire services connection couplings to comply with the technical requirements of the Guidelines for Planning in Bushfire prone Areas. This tank can be accessed by fire appliances via the entrance driveway to the main buildings (No.443) off Kilpatrick Road. The tank is surrounded by a cleared area and access road that provides an asset protection zone equivalent to BAL-29 or lower.

The technical requirements established by the Guidelines and/or the local government can and will be complied with. These requirements are set out in Appendix 3.

5.4 Additional Bushfire Protection Measures

The following bushfire protection measures are to be implemented and maintained. They are additional to those established by the relevant acceptable solutions applied to the land use.

The relevant acceptable solutions are those against which this site has been assessed in Section 5.3 of this Bushfire Management Plan.

5.4.1 Additional Measures to Improve Bushfire Performance

The purpose of risk mitigation treatments is to reduce the likelihood and consequence of bushfire on Armstrong Farms – Tiny Cabin site assets, the community and environment through a process of suitable risk treatment strategies and implementation of suitable treatments to modify the characteristics of the bushfire fuel hazard.

There are a number of possible risk treatment strategies available. When selecting a treatment strategy, or combination of treatment strategies, it is important to keep in mind the wider context of the bushfire risk planning area and consider the level of risk and the type of asset being treated. Not all treatment strategies will be achievable in all circumstances.

Treatments for annual implementation and maintenance programs will include:

- Firebreak and access track maintenance.
- Driveway upgrades and the installation of signage, passing bays and turn-around areas at the Tiny Cabin sites.
- Dedicated water supply for fire-fighting operations.
- Asset protection zones for the Tiny Cabins and construction of cabins to BAL-29 standards.

SUMMARY OF ADDITIONAL BUSHFIRE PROTECTION MEASURES (TREATMENTS) TO BE APPLIED		
Treatment Category	Brief Description	Intent the Treatment Has Been Developed to Help Achieve
Siting and Design	Locating Tiny Cabins on the property where an APZ to achieve 29kW/m ² around each Cabin is achieved.	Avoid areas of BAL-40 or BAL-FZ to lessen the bushfire impact on the cabins and occupants.
Vehicular Access	Upgrading/construction of driveways to the Cabins to achieve the requirements of Table 6 in the <i>Guidelines for Planning in Bushfire Prone Areas</i> .	Vehicular Access – To provide a safe operational environment for emergency services and while occupants are accessing or egressing the site.
Provision of Water	Dedicated 50,000ltrs of water supply for on-site and appropriate access for fire-appliances.	To provide an adequate supply of water for fire-fighting operations to reflect the intent to actively respond during a bushfire event, by the property manager and emergency services.

Firebreak Requirements

Firebreaks are essential within large bush holdings to assist with management and control of bushfire incidents, prevention and environmental activities. Firebreaks are to be maintained in accordance with the annual Shire of Narrogin Firebreak and Fuel Hazard Reduction Notice. The Firebreak Notice is to be reviewed annually to apply any changes in the Notice to the Armstrong Farms property as applicable.

Armstrong Farms firebreaks require maintenance, vegetation pruned back annually prior to the fire season and monitored regularly to ensure ongoing adequacy, especially during the summer months. Particular attention should be given to the main entry/exit driveways to the public roads.

The minimal requirements for firebreaks are:

Firebreak Width — to be a minimum of 2.5 metres wide.

Firebreak Vertical Axis — a continuous vertical uninterrupted line at a right angle to the horizontal line of the firebreak to a minimum height of five (4.5) metres from the ground.

Trafficable — to be able to travel from one point to another in a four wheel drive fire appliance on a clear surface, unhindered without any obstruction that may endanger resources. A firebreak is not to terminate in a dead end without provision for egress to a safe place or a cleared turn around area of 17.5 metre radius.

Private Driveway Requirements

The minimal requirements for the driveway access and egress for the Armstrong Farms is to be upgraded and/or maintained to the standards as detailed in Appendix 2 – Technical requirements for vehicular access.

The access to the Tiny Cabins will be suitable for 2WD vehicles and incorporate turn-around areas at the parking bay for each Cabin.

On-site Fire Suppression

A reticulated water supply is not available to the subject site. The Armstrong Farms has existing water tanks with a minimum storage capacity of 50,000 litres that can be utilised for fire-fighting operations, adjacent to the main equipment shed. Access to the tank is available for emergency services and turn-around for fire appliance around the tank. The tank couplings are to comply with Shire of Narrogin Fire Service requirements and drafting may be carried out from dams on the property as secondary water supplies. The tank is not utilised for domestic potable water for the dwellings.

- Emergency water supplies shall be regularly maintained.

Armstrong Farms has plant and equipment suitable for local bushfire fighting site operations, including 'slip on' fire pump/tank. Management are trained in the use of plant and equipment and bushfire fighting.

5.4.2 Additional Measures Established by the Bushfire Emergency Plan

SPP 3.7 establishes the requirement for a Bushfire Emergency Plan to be developed and used as a bushfire protection measure for 'vulnerable' land uses. The **Armstrong Farms, Hidden Cabins Bushfire Emergency Plan** can be produced as a separate operational document, after subsequent consideration of the scale and merit of the proposed development by the Shire of Narrogin.

It establishes the required actions corresponding to a set of relevant procedures that are to be followed in preparation for a bushfire emergency event and in response to and recovery from, a bushfire emergency event. The responsibility for the facility/premises owner/manager to ensure the requirements of Bushfire Emergency Plan are actioned every year, is established in Section 6 of this Bushfire Management Plan.

6 RESPONSIBILITIES FOR IMPLEMENTATION AND MANAGEMENT OF THE BUSHFIRE PROTECTION MEASURES

Table 6.1: BMP Implementation responsibilities

Landowner/Occupier - Ongoing								
No.	Ongoing Management Actions							
1	<p>Maintain the Asset Protection Zone (APZ) surrounding all relevant buildings to the dimension as determined by either:</p> <ul style="list-style-type: none"> The dimensions corresponding to the indicative BAL of the buildings (refer to Section 3.2 for explanation of the 'planning' versus 'building' requirements and 'indicative' versus 'determined' BAL); and The dimensions corresponding to the local government's Firebreak Notice (if this is greater than the BAL asset protection zone). <p>Maintain the APZ to the standards established by the Guidelines (refer to Appendix 1) or as varied by the relevant local government through their Firebreak Notice (refer to the following responsibility).</p>							
2	<p>Comply with the Shire of Narrogin Firebreak Notice issued under s33 of the Bush Fires Act 1954 and any additional bushfire mitigation requirements.</p> <p>This may include specifications for asset protection zones that differ from the Guideline's APZ Standards, with the intent to better satisfy local conditions. When these are more stringent than those created by the Guidelines, or less stringent and endorsed by the WAPC and DFES, they must be complied with. Refer to Appendix 1.</p>							
3	<p>Maintain driveways, vehicular access routes, passing bays and turn-around areas within the lot to the required surface condition and clearances as stated in the BMP.</p>							
4	<p>Maintain the emergency water supply tanks and the associated fittings in good working condition and vehicular access. Maintaining the emergency water supply at required capacities. Maintain an asset protection zone around the tanks to the corresponding BAL-29 distances.</p> <table border="1" data-bbox="331 1346 1319 1458"> <tbody> <tr> <td>Class D Scrub</td> <td>Upslope or flat 0</td> <td rowspan="2">BAL-29</td> <td>13</td> </tr> <tr> <td>Class A Forest</td> <td>Upslope or flat 0</td> <td>21</td> </tr> </tbody> </table>	Class D Scrub	Upslope or flat 0	BAL-29	13	Class A Forest	Upslope or flat 0	21
Class D Scrub	Upslope or flat 0	BAL-29	13					
Class A Forest	Upslope or flat 0		21					
5	<p>Program the maintaining of pasture areas to minimal fuel loadings to reduce fire spread.</p>							
6	<p>Ensure that any builders (of future structures on the lot) are aware of the existence of this Bushfire Management Plan and the responsibilities it contains regarding the application of construction standards corresponding to a determined BAL.</p>							
7	<p>Ensure all future buildings the landowner has responsibility for, are designed and constructed in full compliance with:</p> <ol style="list-style-type: none"> the requirements of the WA Building Act 2011 and the bushfire provisions of the Building Code of Australia (BCA); and with any identified additional requirements established by this BMP or the relevant local government. 							
8	<p>To implement and maintain, the additional bushfire protection measures contained in Section 5.4 of this Bushfire Management Plan, in addition to the measures that are established by the acceptable solutions.</p>							
10	<p>Instal signage to driveways and access routes, identifying location and route to safer locations & assembly areas on site.</p>							

APPENDIX 1: TECHNICAL REQUIREMENTS FOR ONSITE VEGETATION MANAGEMENT

A1.1 Requirements Established by the Guidelines – Standards for Asset Protection Zones

(Source: Guidelines for Planning in Bushfire Prone Areas - WAPC 2017 v1.3 Appendix 4, Element 2, Schedule 1 and Explanatory Note E2.1)

DEFINING THE ASSET PROTECTION ZONE (APZ)

Description: An APZ is an area surrounding a building that is managed to reduce the bushfire hazard to an acceptable level (by reducing fuel loads). The width of the required APZ varies with slope and vegetation and varies corresponding to the BAL rating determined for a building (lower BAL = greater dimensioned APZ).

For planning applications, the minimum sized acceptable APZ is that which is of sufficient size to ensure the potential radiant heat impact of a fire does not exceed 29kW/m² (BAL-29). It will be site specific.

For subdivision planning, design elements and excluded/low threat vegetation adjacent to the lot(s) can be utilised to achieve the required vegetation separation distances and therefore reduce the required dimensions of the APZ within the lot(s).

Defendable Space: The APZ includes a defendable space which is an area adjoining the asset within which firefighting operations can be undertaken to defend the structure. Vegetation within the defendable space should be kept at an absolute minimum and the area should be free from combustible items and obstructions. The width of the defendable space is dependent on the space, which is available on the property, but as a minimum should be 3 metres.

Establishment: The APZ should be contained solely within the boundaries of the lot on which the building is situated, except in instances where the neighbouring lot or lots will be managed in a low-fuel state on an ongoing basis, in perpetuity.

The APZ may include public roads, waterways, footpaths, buildings, rocky outcrops, golf courses, maintained parkland as well as cultivated gardens in an urban context, but does not include grassland or vegetation on a neighbouring rural lot, farmland, wetland reserves and unmanaged public reserves.

[Note: Regardless of whether an Asset Protection Zone exists in accordance with the acceptable solutions and is appropriately maintained, fire fighters are not obliged to protect an asset if they think the separation distance between the dwelling and vegetation that can be involved in a bushfire, is unsafe.]

Schedule 1: Standards for APZ

Fences: within the APZ are constructed from non-combustible materials (e.g. iron, brick, limestone, metal post and wire). It is recommended that solid or slatted non-combustible perimeter fences are used.

Objects: within 10 metres of a building, combustible objects must not be located close to the vulnerable parts of the building i.e. windows and doors.

Fine Fuel Load: combustible dead vegetation matter less than 6 mm in thickness reduced to and maintained at an average of two tonnes per hectare (example below).



Example: Fine fuel load of 2 t/ha

(Image source: Shire of Augusta Margaret River's Firebreak and Fuel Reduction Hazard Notice)

Trees (> 5 metres in height): trunks at maturity should be a minimum distance of 6 metres from all elevations of the building, branches at maturity should not touch or overhang the building, lower branches should be removed to a height of 2 metres above the ground and or surface vegetation, canopy cover should be less than 15% with tree canopies at maturity well spread to at least 5 metres apart as to not form a continuous canopy. Diagram below represents tree canopy cover at maturity.

Tree canopy cover – ranging from 15 to 70 per cent at maturity

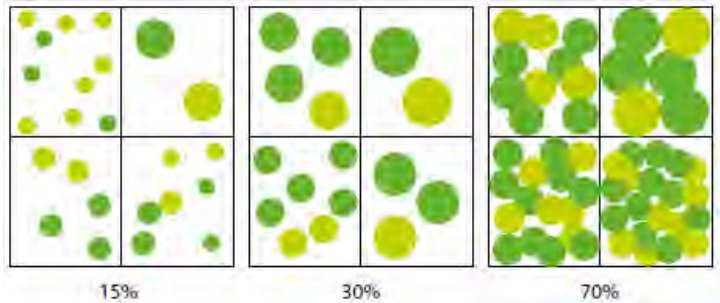

(Source: Guidelines for Planning in Bushfire Prone Areas 2017, Appendix 4)

Shrubs (0.5 metres to 5 metres in height): should not be located under trees or within 3 metres of buildings, should not be planted in clumps greater than 5m² in area, clumps of shrubs should be separated from each other and any exposed window or door by at least 10 metres. Shrubs greater than 5 metres in height are to be treated as trees.

Ground covers (<0.5 metres in height): can be planted under trees but must be properly maintained to remove dead plant material and any parts within 2 metres of a structure, but 3 metres from windows or doors if greater than 100 mm in height. Ground covers greater than 0.5 metres in height are to be treated as shrubs.

Grass: should be managed to maintain a height of 100 mm or less.

The following example diagrams illustrate how the required dimensions of the APZ will be determined by the type and location of the vegetation.

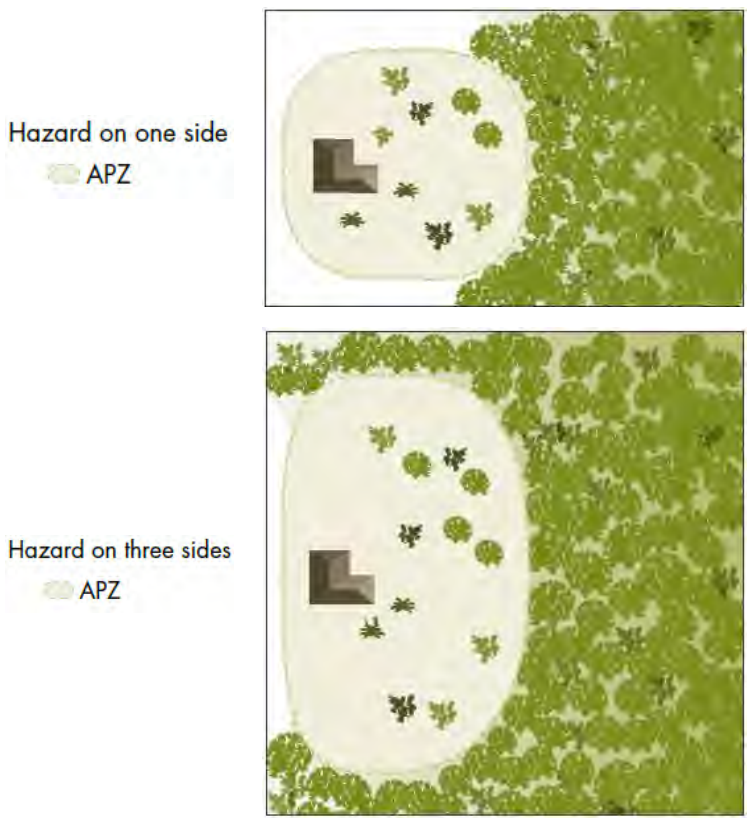

A1.2 Requirements Established by the Local Government – the Firebreak Notice

The relevant local government's current Firebreak Notice is available on their website, at their offices and is distributed as ratepayer's information. It must be complied with.

These requirements are established by the relevant local government's Firebreak Notice created under s33 of the Bushfires Act 1954 and issued annually (potentially with revisions). The Firebreak Notice may include additional components directed at managing fuel loads, accessibility and general property management with respect to limiting potential bushfire impact.

If Asset Protection Zone (APZ) specifications are defined in the Firebreak Notice, these may differ from the Standards established by the Guidelines, with the intent to better satisfy local conditions. When these are more stringent than those created by the Guidelines, or less stringent and endorsed by the WAPC and DFES, they must be complied with.

The APZ dimensions to be physically established and maintained, will be based on which of the following establishes the larger APZ dimension:

- The dimensions corresponding to the determined BAL of a building (refer to Section 3.2 explanation of the 'planning' versus 'building' requirements and 'indicative' versus 'determined' BAL(s)); or
- The APZ dimensions established by the local government's Firebreak Notice.

A1.3 Requirements Recommended by DFES – Property Protection Checklists

Further guidance regarding ongoing/lasting property protection (from potential bushfire impact) is presented in the publication 'DFES – Fire Chat – Your Bushfire Protection Toolkit'. It is available from the Department of Fire and Emergency Services (DFES) website.

A1.4 Requirements Established by AS 3959:2018 – 'Minimal Fuel Condition'

This information is provided for reference purposes. This knowledge will assist the landowner to comply with Management Requirement No. 3 set out in the Guidance Panel at the start of this Appendix. It identifies what is required for an area of land to be excluded from classification as a potential bushfire threat.

"Australian Standard - AS 3959:2018 Section 2.2.3.2: Exclusions - Low threat vegetation and non-vegetated areas:

The Bushfire Attack Level shall be classified BAL-LOW where the vegetation is one or a combination of the following:

- a) Vegetation of any type that is more than 100m from the site.*
- b) Single areas of vegetation less than 1ha in area and not within 100m of other areas of vegetation being classified vegetation.*
- c) Multiple area of vegetation less than 0.25ha in area and not within 20m of the site or each other or other areas of vegetation being classified vegetation.*
- d) Strips of vegetation less than 20m in width (measured perpendicular to the elevation exposed to the strip of vegetation) regardless of length and not within 20m of the site or each other, or other areas of vegetation being classified vegetation.*
- e) Non-vegetated areas, that is, areas permanently cleared of vegetation, including waterways, exposed beaches, roads, footpaths, buildings and rocky outcrops.*
- f) Vegetation regarded as low threat due to factors such as flammability, moisture content or fuel load. This includes grassland managed in a **minimal fuel condition**, (means insufficient fuel available to significantly increase the severity of a bushfire attack – for example, recognisable as short cropped grass to a nominal height of 100mm), mangroves and other saline wetlands, maintained lawns, golf courses (such as playing areas and fairways), maintained public reserves and parklands, sporting fields, vineyards, orchards, banana plantations, market gardens (and other non-curing crops), cultivated gardens, commercial nurseries, nature strips and windbreaks (single row of trees)."*

APPENDIX 2: TECHNICAL REQUIREMENTS FOR VEHICULAR ACCESS

Each local government may have their own standard technical requirements for emergency vehicular access, and they may vary from those stated in the Guidelines.

When required, these are stated in Section 5.1 of this bushfire management plan.

Requirements Established by the Guidelines – The Acceptable Solutions

(Source: Guidelines for Planning in Bushfire Prone Areas WAPC 2017 v1.3, Appendix 4)

VEHICULAR ACCESS TECHNICAL REQUIREMENTS - PART 1

Acceptable Solution 3.5: Private Driveways

The following requirements are to be achieved:

- The design requirements set out in Part 2 of this appendix; and

Where the house site is more than 50 metres from a public road:

- Passing bays every 200 metres with a minimum length of 20 metres and a minimum width of two metres (ie combined width of the passing bay and constructed private driveway to be a minimum six metres);
- Turn-around areas every 500 metres and within 50 metres of a house, designed to accommodate type 3.4 fire appliances to turn around safely (ie kerb to kerb 17.5 metres);
- Any bridges or culverts are able to support a minimum weight capacity of 15 tonnes; and
- All weather surface (i.e. compacted gravel, limestone or sealed).

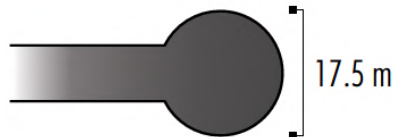
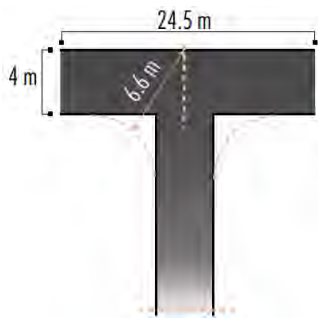

Acceptable Solution 3.8: Firebreak Width

Lots greater than 0.5 hectares must have an internal perimeter firebreak of a minimum width of three meters or to the level as prescribed in the local firebreak notice issued by the local government.

VEHICULAR ACCESS TECHNICAL REQUIREMENTS - PART 2

Technical Component	Vehicular Access Types				
	Public Roads	Cul-de-sacs	Private Driveways	Emergency Access Ways	Fire Service Access Routes
Minimum trafficable surface (m)	6*	6	4	6*	6*
Horizontal clearance (m)	6	6	6	6	6
Vertical clearance (m)	4.5	4.5	4.5	4.5	4.5
Maximum grade <50 metres	1 in 10	1 in 10	1 in 10	1 in 10	1 in 10
Minimum weight capacity (t)	15	15	15	15	15
Maximum cross-fall	1 in 33	1 in 33	1 in 33	1 in 33	1 in 33
Curves minimum inner radius (m)	8.5	8.5	8.5	8.5	8.5

* A six metre trafficable surface does not necessarily mean paving width. It could, for example, include four metres of paving and one metre of constructed road shoulders. In special circumstances, where 8 lots or less are being serviced, a public road with a minimum trafficable surface of four metres for a maximum distance of ninety metres may be provided subject to the approval of both the local government and DFES.

VEHICULAR ACCESS TECHNICAL REQUIREMENTS – GATES AND SIGNS EXAMPLES

Gates

Design and construction to be approved by relevant local government.

- Minimum width 3.6m
- Emergency access way gates must not be locked.
- Fire service access route gates may be locked but only with a common key that is available to local fire service personnel.
- Bollards will be to the relevant local government specifications

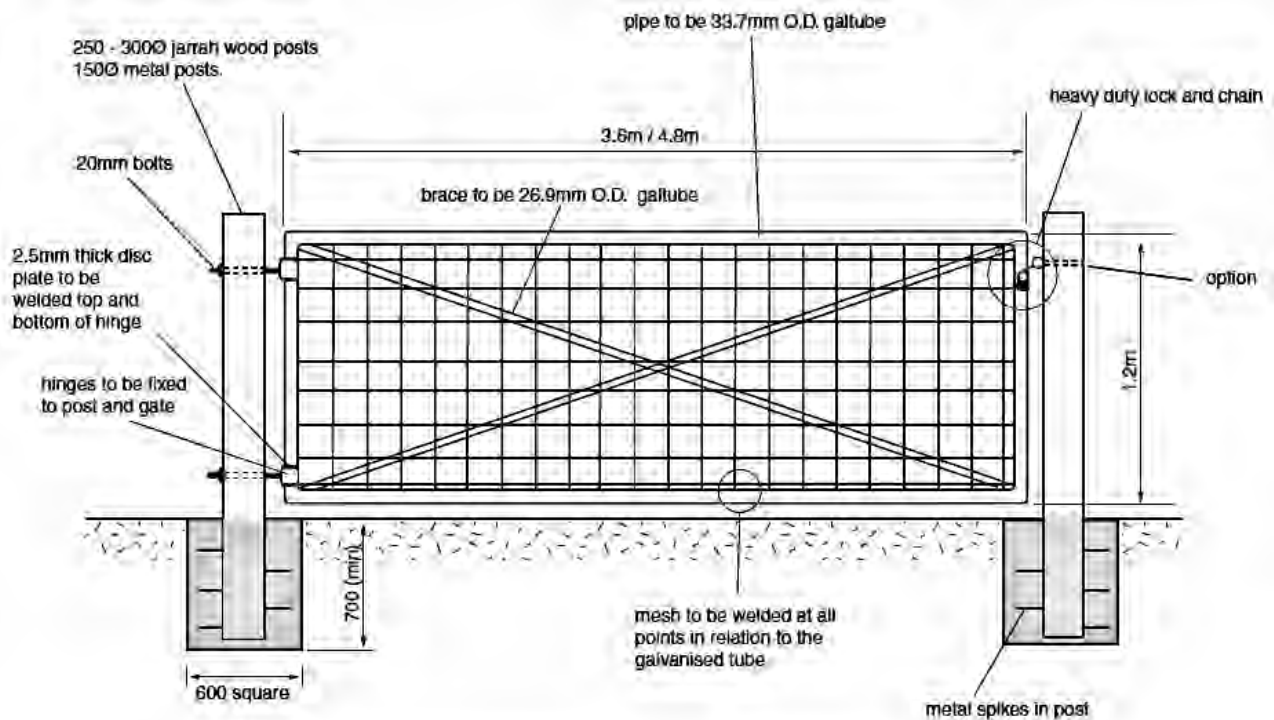

Note: Mesh to be metric mesh 46G5 and galvanised finish complete with fittings.

Signs

Design and construction to be approved by the relevant local government/meet industry standards.

- Minimum height above ground of 0.9m.
- Lettering height to be 100mm.
- To display the words (as appropriate) "Emergency Assembly Area" or "Evacuation Route" (or as appropriate)
- Size 600mm x 400mm.
- Sign colour green, base (white) area is reflective background.
- Rounded corners, radius 20mm.
- White key-line 3mm wide, 3mm from outside edge.
- Suggested mounting hole 6mm diameter.
- Alternative Directional Signage, turn-around point, steep descent & passing bay, should meet required standards.



APPENDIX 3: TECHNICAL REQUIREMENTS FOR FIREFIGHTING WATER

Non-Reticulated Areas

Each local government may have their own standard technical requirements for firefighting water supplies, and they may vary from those stated in the Guidelines.

Table A4.2: Non-reticulated areas – water supply technical requirements.

TECHNICAL REQUIREMENTS FOR STATIC WATER SUPPLY (EXAMPLE ONLY – CHECK WITH LOCAL GOVERNMENT)	
Application:	Where the intention is to actively defend property and infrastructure. To provide an adequate supply of water for firefighting purposes to reflect the intended response to a bushfire event, by emergency services and/or the owner/occupier.
Volume:	Provision of a minimum 50,000 litre static water supply (can be a combined capacity from multiple tanks) for firefighting purposes, to the satisfaction of the local government. (In addition to the capacity required to accommodate the sprinkler deluge system). The storage tank should not facilitate sharing the water for domestic potable use due to the potential of contamination from firefighting foam (incorporate a non-return valve).
Tank Construction:	Above ground tanks constructed using concrete or metal.
Pipe Construction:	Galvanised or copper (PVC if buried at least 300mm below ground).
Vehicle Access:	Hardstand and turnaround area suitable for a 3.4 appliance (i.e. kerb to kerb 17.5metres) is provided at the tank.
Couplings:	Tanks are to be fitted with a full flow gate valve (not ball valve) and a 50mm or 100mm cam-lock coupling of metal/alloy construction (example below).
Signage:	Multiple buildings and/or firefighting water supplies may require directional signage to guide firefighters to the emergency water supplies.
Responsibility:	A procedure must be in place to ensure that water tanks are maintained at or above designated capacity always.

[Sources: Guidelines for Planning in Bushfire Prone Areas WAPC 2017 v1.3, Appendix 4, Element 4 with example construction / coupling requirements from various sources including FESA (DFES) Operational Circular 07/2011 and Planning for Bushfire Protection Guidelines WAPC 2010]

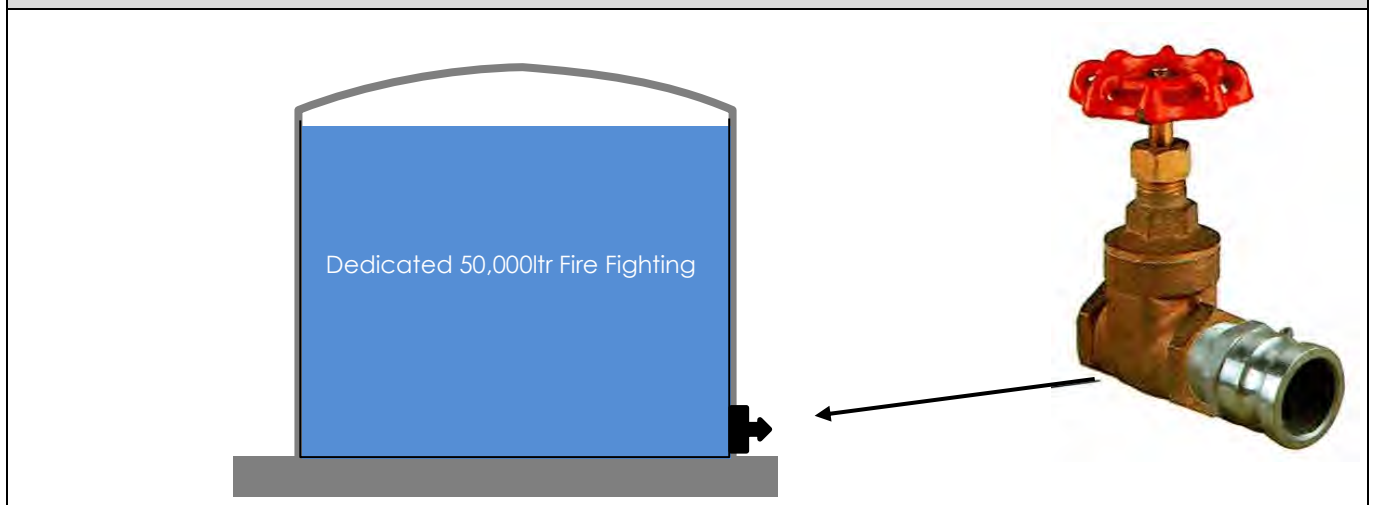

10.1.2 APPLICATION FOR PLANNING CONSENT: CONSULTING ROOMS (MEDICAL CENTRE) AT LOT 23 (SHOP 1. NO. 83) FEDERAL STREET, NARROGIN

File Reference	A162900
Disclosure of Interest	Neither the Author nor Authorising Officer have any Impartiality, Financial or Proximity Interests that requires disclosure
Applicant	South West Aboriginal Medical Service Aboriginal Corporation
Previous Item Numbers	Nil
Date	9 June 2021
Author	David Johnston – Planning Officer
Authorising Officer	Azhar Awang – Executive Manager Development and Regulatory Services
Attachments	1. Cover Letter 2. Floor Plan

Summary

Council is requested to consider an Application for Planning Consent for proposed Consulting Rooms at Lot 23 (Shop 1. No. 83) Federal Street, Narrogin.

Background

On 28 May 2021, the Shire of Narrogin received an Application for Planning Consent from South West Aboriginal Medical Service Aboriginal Corporation. The Application is for establishment of a Medical Centre (Consulting Rooms) with up to six staff, however the Centre will operate initially with five staff. Three of the positions are consultants and the other positions are support staff.

The purpose of the Consulting Rooms, according to the applicant is to provide *“culturally appropriate primary health care services, chronic conditions management, prevention and early intervention programmes and maternal and child health.”*

Consultation

Under Clause 6.3 of the Former Town of Narrogin Town Planning Scheme No. 2 (FTPS2) for ‘PS’ uses, Council may give notice of the Application but is not required to do so.

It is requested that the Council dispense of public advertising as per Clause 6.3 on the basis that similar approvals for Consulting Rooms have not attracted any negative feedback.

Statutory Environment

Sections of the Acts, Regulations and/or Local Laws that apply to this item include:

- Planning and Development Act 2005
- Former Town of Narrogin: Town Planning Scheme No. 2

Policy Implications

Nil

Financial Implications

An Application for Planning Consent Fee of \$147 has been paid to the Shire of Narrogin.

Clause 3.3.2(a)(i) of the FTPS2, states:

“a cash-in-lieu payment shall be not less than the estimated cost to the owner of providing and constructing the parking spaces required by the Scheme, plus the value, as estimated by the Valuer General of Western Australia, of that area of his land which would have been occupied by the parking spaces;”

The cost for each car parking bay is \$9,000 and based on the FTPS2, 12 bays will be required. The application proposes all staff carparking to be contained on site (5 staff), the additional 7 bays as on-street parking. The Administration is recommending that this requirement be waived.

Strategic Implications

Shire of Narrogin Strategic Community Plan 2017-2027		
Objective:	1.	Economic Objective (Support growth and progress, locally and regionally)
Outcome:	1.1	Growth in revenue opportunities
Strategy:	1.1.1	Attract new industry, business, investment and encourage diversity whilst encouraging growth of local business
Strategy:	1.1.2	Promote Narrogin and the Region
Strategy:	1.1.3	Promote Narrogin's health and aged services including aged housing
Outcome:	2.2	Build a healthier and safer community
Strategy:	2.2.1	Support the provision of community security services and facilities
Strategy:	2.2.2	Advocate for mental health and social support services
Outcome:	2.3	Existing strong community spirit and pride is fostered, promoted and encouraged
Strategy:	2.4.2	Support our Narrogin cultural and indigenous community

Comment/Conclusion

Zoning

Lot 23 (No. 83) Federal Street, Narrogin is zoned “Central Business Zone” under the FTPS2. The Policy Statement for the zoning states:

“To provide for the function and development of the town centre primarily for retail shops and offices, Council will control the development of other uses and co-ordinate such uses to ensure that compatible development occurs in like areas.”

The proposed Consulting Rooms (Medical Centre) falls under the definition of 'Consulting Rooms Group', which:

"means a building (other than a hospital or medical centre) used by more than two practitioners who are legally qualified medical practitioners or dentists, physiotherapists, chiropractors, and person(s) ordinarily associated with a practitioner, in the prevention, investigation or treatment of physical or mental injuries or ailments, and the practitioners may be of the one profession or any combination of professions or practices."

This use although defined in Clause 1.8 of FTSP2, is not listed in any of the use-class tables. The use can also be defined as a 'Consulting Rooms' which:

"means a building (other than a hospital or medical centre) used by no more than two practitioners who are legally qualified medical practitioners or dentists, physiotherapists, chiropractors, and person(s) ordinarily associated with the treatment of physical or mental injuries or ailments, and the two practitioners may be of the one profession or any combination of professions or practices."

Consulting Rooms is listed as a 'PS' use under the 'Central Business Zone', which means:

"Use not permitted unless special approval given by Council and conditions complied with."

Clause 6.3 – Application for Special Approval of the FTSP2 states as follows:

"6.3.1 The Council shall in the case of an application for permission to carry on a use marked AP in the Development Table and may in the case of an application for permission to carry on a use marked PS in the Development Table or in any other case in which application is made for its approval give notice of the application in accordance with the provisions of this Clause."

6.3.2 Where the Council is required or decides to give notice of an application the Council shall cause:

- a) notice of the proposed use and development to be sent by post or delivered to the owners and occupiers of land within an area determined by the Council as likely to be affected by the granting of the application;*
- b) notice of the proposed use and development to be published in a newspaper circulating in the Scheme Area and in the State of Western Australia stating that submissions may be made to the Council within 21 days from the publication thereof; and*
- c) a sign displaying notice of the proposed use and development to be erected in a conspicuous position on the land for a period of 21 days from the date of publication of the notice referred to in paragraph (b) hereof."*

Clause 6.3.5 further states:

"6.3.5 A resolution to grant special approval must be passed by an absolute majority of the Council."

Furthermore, clause 6.2, provides Council the ability for the relaxation on the provisions of the Planning Scheme as follow:

"6.2 RELAXATION OF STANDARDS"

6.2.1 If a development is the subject of an application for planning consent and does not comply with a standard or requirement prescribed by the Scheme, the Council may approve the application

unconditionally or subject to such conditions as the Council thinks fit, always provided that the Council is satisfied that:

- a) approval of the proposed development would be consistent with the orderly and proper planning of the locality, the preservation of the amenity of the area and be consistent with the objectives of the Scheme;
- b) the non-compliance will not have any adverse effect upon the occupiers or users of the development or the inhabitants of the locality or upon the likely future development of the locality; and
- c) the spirit and purpose of the requirements or standards will not be unreasonably departed from thereby.”

Heritage

Under the Shire of Narrogin Local Heritage Survey 2019, Lot 23 (No. 83) Federal Street, Narrogin is heritage listed as Place No. 56. The building which is the former Manning Stores is listed as Grade B in the Local Heritage Survey 2019. This means:

“High level of cultural heritage significance to Shire of Narrogin ‘Heritage List.’ TPS: Development Application. Retain & conserve.”

The Application does not propose any changes to the exterior of the building and only minor changes in the consulting rooms. This includes replacing carpet with linoleum and adding basins.

Car Parking

The minimum permitted parking within the ‘Central Business Zone’ for a Consulting Room is four (4) bays per consultant and as there are three consultants, the development will require a total of 12 bays.

The five staff will park at the rear of the building where there is estimated to be space for 16 bays in total. Other businesses at 83 Federal Street require approximately eight bays leaving another eight bays available. This will need to be confirmed through formalising the carpark. The parking at the rear, although on under the same ownership, is on a different lot. Formalisation of the carpark would require an amalgamation to take place.

Given an estimated eight bays free, the shortfall of parking bays is four bays. It is anticipated that there may be up to 20 Clients attending the premises per week and a maximum of four clients at any one time.

On street parking is available at the front of the premises, along Fairway Street and behind the building. There are usually several vacant bays along Federal Street in front of the premises.

It is recommended that the property owner formalised the car parking at the rear of the property to allow car parking to be provided within the property boundary.

Clause 3.3.2 provides Council the ability to accept cash in lieu payment for the shortfall of car parking on site.

Toilets

The existing building has shared toilets for use by the Medical Centre and other attached businesses. There are two pans and one urinal for men and two pans for women. There are no universal access

toilets in the building. In this application, which is a Change of Use, a Universal Access Toilet will be required as per Australian Standard 1428 and the National Construction Code.

Voting Requirements

Part 1 of 2 – Simple Majority

Part 2 of 3 – Simple Majority

Part 3 of 3 – Absolute Majority

OFFICERS' RECOMMENDATION – PART 1 OF 3

That, with respect to Application for Planning Consent: Consulting Rooms (Medical Centre) at Lot 23 (Shop 1. No. 83) Federal Street, Narrogin, Council dispenses with any advertising of the Planning Application in accordance with Clause 6.2 of the Former Town of Narrogin Town Planning Scheme No. 2.

OFFICERS' RECOMMENDATION – PART 2 OF 3

That, with respect to Application for Planning Consent: Consulting Rooms (Medical Centre) at Lot 23 (Shop 1. No. 83) Federal Street, Narrogin, Council approves the dispensation of the minimum car parking requirements in accordance with Clause 6.2.1 of the Former Town of Narrogin Town Planning Scheme No. 2 for the following reasons:

- Staff parking can be provided on site.
- There is an adequate number of on-street parking available in the area around the proposed Consulting Rooms.
- The shortfall of car parking will not adversely impact on the available public parking around the area.

OFFICERS' RECOMMENDATION – PART 3 OF 3

That, with respect to Application for Planning Consent: Consulting Rooms (Medical Centre) at Lot 23 (Shop 1. No. 83) Federal Street, Narrogin, Council grant Planning Approval subject to the following conditions:

1. The approval shall expire if the development permitted is not completed within two years of approval, or within any extension of that time which, upon written application (made before or within 21 days after the expiry of the approval) to the Shire is granted by it in writing.
2. The development approved shall be in accordance with the plans and specifications submitted with the application and these shall not be altered or modified without the prior written approval of the Chief Executive Officer.
3. Any use, additions to and further intensification of any part of the development or land which is not in accordance with the original application or conditions of approval shall be subject to a further development application and consent for that use.

Continued over page

4. All signage is to be in accordance with the Shire of Narrogin's local laws, unless further approval is granted by the Shire of Narrogin.
5. A parking plan is to be submitted to the Shire within six months of this approval demonstrating that all staff parking associated with the activity approved is wholly contained on site and subsequently parking will be formalised to the satisfaction of the Chief Executive Officer.
6. The applicant is to submit an application to amalgamate lots 23, 54 and 200 to the Western Australian Planning Commission within twelve months of this approval.
7. A Universal Access Toilet is to be installed on site to the satisfaction of the Chief Executive Officer.

Advice Note:

1. If the applicant and/or owner are aggrieved by this decision as a result of the conditions of approval or by a determination of refusal, there may be a right of review under the provisions of Part 14 of the Planning and Development Act 2005. A review must be lodged with the State Administrative Tribunal within 28 days of the decision.



Our Health, Our Way

Shire of Narrogin
89 Earl Street, Narrogin WA 6312

To whom this may concern,

Re: Lease of Shop 1, 83 Federal Street, Narrogin WA 6312

I am writing to you on behalf of the South West Aboriginal Medical Service (SWAMS), to seek special approval from The Council to utilise the above-mentioned address as 'Consulting Rooms'.

SWAMS are a not-for-profit, community-controlled health organisation with the primary focus of improving the health and wellbeing of Aboriginal people. SWAMS was established in 1997 and currently our service locations include the Greater Bunbury Area, Busselton, Brunswick, Harvey, Collie, Manjimup and Katanning.

We have recently been funded by the Australian Government Department of Health to deliver health care services in Narrogin and surrounding towns. SWAMS has attended numerous visits and community engagement activities with Aboriginal residents of Narrogin, who have welcomed SWAMS and the service that we will provide.

The SWAMS Narrogin Clinic will focus on providing culturally appropriate primary health care services, chronic conditions management, prevention and early intervention programmes (including programmes which focus on diabetes; cancer; heart health; mental health and suicide prevention; tobacco and alcohol use) and maternal and child health. The staff required to deliver these services will include:

- General Practitioner 1 x staff member
- Aboriginal Health Practitioner and Outreach Worker 1 x staff member
- Mental Health Counsellor 1 x staff member
- Transport Driver 1 x staff member
- Practice Support Officer 1 x staff member

For all the above-mentioned positions SWAMS will endeavour to hire locally, creating an initial five positions. SWAMS will deliver essential services to its clients in a culturally safe and appropriate manner, with access to unique services unlike any organisation in the mainstream.

Since April 2021, SWAMS have been in discussions with the owners of Shop 1, 83 Federal Street, regarding leasing the building for the purpose of providing health care services to Aboriginal people in Narrogin. On the attached floorplan I have indicated what each room will be used for.

SWAMS estimates we will have around 20 clients per week attend the service and as such feel the street parking in Narrogin CBD will be adequate for client parking. Staff will be able to park at the rear of the building, in the gravel car park adjacent to Fairway street and part of the building complex.

Bunbury Clinic

Unit 5/55 Forrest Ave, Bunbury WA 6230
P: (08) 9726 6000 | F: (08) 9791 7655 | E: records@swams.com.au

Administration

Unit 3/30 Wellington St, Bunbury, WA 6230
P: (08) 9797 8111 | E: info@swams.com.au

We hope that you will see fit to accept our application to provide this essential service to the Aboriginal and wider population of Narrogin. We look forward to your response.

Yours faithfully,

Ms Lesley Nelson



Chief Executive Officer

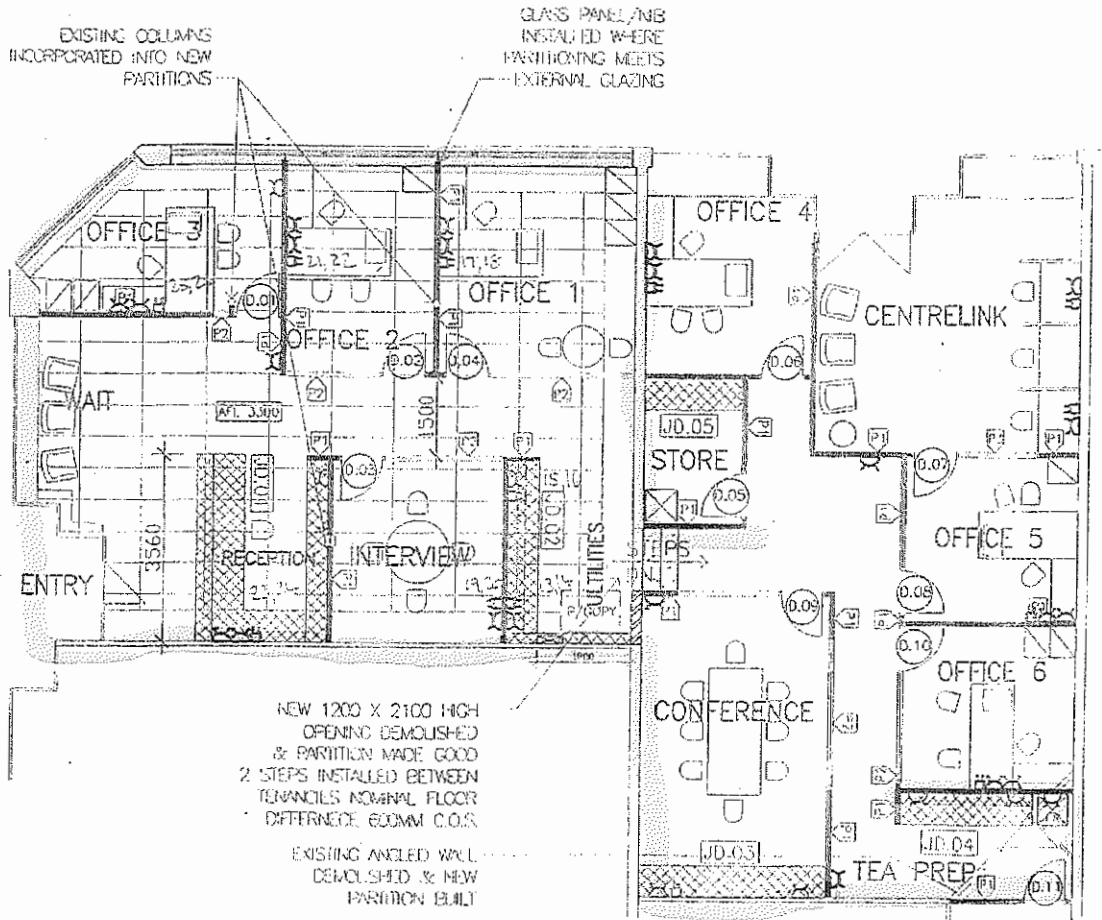

A.01 HOTHAM PERSONNEL - PLAN VIEW
SCALE 1:100

- ELECTRICAL/DATA LEGEND**
- Ⓜ DENOTES DUAL DATA CABLE @ 200MM ABOVE FINISH FLOOR LEVEL
 - Ⓧ DENOTES DUAL DATA (POWER) CABLE @ 300MM ABOVE FINISH FLOOR LEVEL
 - Ⓝ DENOTES DUAL DATA CABLE @ 1200MM ABOVE FINISH FLOOR LEVEL
 - Ⓟ DENOTES DUAL DATA (POWER) CABLE @ 200MM ABOVE FINISH FLOOR LEVEL
- PAINT/WALL COLOURS**
- GENERAL WALL COLOUR - CELEST (MILK) WHITE
 - REAR WALL COLOUR 1 - WATER TREAT SOFT BROWN (MAY BE EITHER 1 OR 2)
 - REAR WALL COLOUR 2 - WATER TREAT (MAY BE EITHER 1 OR 2)

- LEGEND**
- DENOTES EXISTING WALLS/PARTITIONS TO REMAIN
 - ▴ DENOTES EXISTING DOOR TO REMAIN
 - Ⓞ.10 DENOTES NEW DOOR REFER TO DOOR SCHEDULE
 - DENOTES SOLID FULL HEIGHT PARTITION 13MM PLASTERBOARD EITHER SIDE OF 60MM METAL STUD FRAMING WITH 75 mm TONINE INSULATION INFILL 100mm HIGH NATURAL ANODISED ALUM. SKIRTING BOTH SIDES
 - DENOTES GLAZED FULL HEIGHT PARTITION IN 2400 HIGH (PLASTERBOARD ABOVE TO 3500 HIGH) (TO GLAZING CODE) IN TUSSEMAKERS 700 SERIES NATURAL ANODISED ALUM. FRAME
 - DENOTES SOLID PARTITION TO 1200 HIGH 13MM PLASTERBOARD EITHER SIDE OF 60MM METAL STUD FRAMING WITH 75 mm TONINE INSULATION INFILL GLAZING FROM 1200 TO 2400 HIGH (PLASTERBOARD ABOVE) IN TUSSEMAKERS 700 SERIES NAT. ANODISED ALUM. NATURAL ANODISED ALUM. SKIRTING BOTH SIDES 100mm HIGH NATURAL ANODISED ALUM. SKIRTING BOTH SIDES
- JOINERY DETAILS**
- DENOTES NEW JOINERY ITEM - SEE DETAILS BELOW
 - JD.01 NEW RECEPTION DESK/COUNTER WITH FULL HEIGHT CLASSBOARD AT REAR
 - JD.02 900MM HIGH TRENCH WITH 30MM DEEP (MILK) BROWN CUPBOARDS
 - JD.03 600MM HIGH CREDENZA UNIT
 - JD.04 900MM HIGH KITCHEN ISLAND WITH 30MM DEEP (MILK) BROWN CUPBOARDS
 - JD.05 SINK/STOVE CUPBOARD WITH DOORS & ADJUSTABLE CHAIRING
- MFP CLOSET AND PARTITION ON SITE BEING DEMOLISHED

NOTES

All elements of the drawing are controlled by Interiors Australia. All dimensions are in millimetres unless otherwise stated. All dimensions shall be used. Do not scale Drawing. The contractor shall verify all dimensions on site prior to commencement of work.

Date	By	Description	Issue	Auth
11.09.20	J	LAYOUT REVISED	SUP	MA
11.09.20	J	LAYOUT REVISED	YLD	MA
16.10.20	J	WALL COLOUR ADDED	MA	MA

CLIENT

Hotham Personnel

Unit 10, Eureka House
216 St Georges Tce, Perth WA 6000
Tel: 08 9437 7126
Email: info@interiors.com.au
www.interiors.com.au

PROJECT

New Office Fitout

ADDRESS

Narrogin - Cnr. of Federal / Fortune St.

DRAWING TITLE

Proposed Layout Plan

APPROVED FOR CONSTRUCTION

DESIGNED/DRAWN	DATE	SCALE
J	14/09/20	1:100 @ A3
SUP		
PROJECT MANAGER	DATE	
A.01-01-01 HOTHAM PERSONNEL - PLAN VIEW		
DATE	PROJECT NUMBER	
	A3	PT 06067
PROJECT NUMBER		Page 113

10.2 TECHNICAL AND RURAL SERVICES

10.2.1 REVISED TEN YEAR FOOTPATH CONSTRUCTION PROGRAM 2021-2031

File Reference	28.4.4
Disclosure of Interest	Neither the Author nor Authorising Officer have any Impartiality, Financial or Proximity Interests that requires disclosure.
Applicant	Shire of Narrogin
Previous Item Numbers	Item 10.1.061, 28 June 2017 Res. 0617.073 Item 10.2.2, 24 April 2019 Res. 0419,010
Date	27 May 2021
Author	Torre Evans – Executive Manager Technical & Rural Services
Authorising Officer	Dale Stewart – Chief Executive Officer
Attachments	<ol style="list-style-type: none">1. Revised Ten Year Footpath Construction Program 2021-20312. Narrogin Urban Map Showing Proposed Footpaths

Summary

Council is requested to consider adopting the revised Ten Year Footpath Construction Program 2021-2031 as presented in Attachment 1. This program is a planned direction for new footpath construction and replacement of footpaths that have reached the end of their asset life cycle and do not meet an acceptable standard of service and safety.

The program enables the Shire's budgeting process to be planned and continue into the future including the Shire's Long Term Financial Plan and Annual Budgeting.

Background

Council adopted a Ten Year Footpath Construction Program 2019-2029 at the Ordinary Council meeting of 24 April 2019, with this program adhered up to and including the 2020/21 financial year.

The revised program presented, is a continuation of the current program with no changes except for additional new footpaths post 2028.

It is prudent for the Executive Manager Technical & Rural Services (EMTRS) to draft a revised Ten Year Footpath Program for budgeting purposes, to demonstrate the Shire's ability to recognise and manage this valuable community asset and have a strategic program in place, in the event that unforeseen grant funding becomes available.

Consultation

Consultation on the revised Footpath Program was conducted with:

- Chief Executive Officer, and
- Manager Operations.

Statutory Environment

Local Governments are required to have Asset Management Plans in place pursuant Local Government Act 1995.

Policy Implications

Council Policy 12.11 Asset Management Plans relates.

Financial Implications

The revised Ten Year Footpath Program will need to be considered in the context of the Shire's Long Term Financial Plan and Annual Budgeting process.

Attachment 1 addresses the financial implications for the revised Ten Year Footpath Program.

Strategic Implications

Shire of Narrogin Strategic Community Plan 2017-2027	
Objective	2. Social Objective (To provide community facilities and promote social interaction)
Objective	3. Environment Objective (Conserve, protect and enhance our natural and built environment)
Outcome:	3.4 A well maintained built environment
Strategy:	3.4.1 Improve and maintain built environment

Comment/Conclusion

The revised Ten Year Footpath Program identifies locations with high residential concentration and pedestrian traffic connecting to places of important community interest i.e. schools, aged care, hospital and the CBD shopping precinct and therefor priority has been given to these locations. The program also considers existing asphalt, concrete slab or old chip sealed footpaths in a poor condition to be replaced with new.

The proposed footpath construction lengths have been calculated to provide new concrete footpaths with a width of 1.8m and to a cost on average of around \$50,000 per financial year which has been the practice and budget allocation for a number of years inclusive of the current adopted Ten Year Footpath Program.

Some footpath locations will include kerb ramps, handrails and tactile ground stickers (to provide additional traction) to assist users with disabilities, users on mobility transport such as gophers and wheelchairs or users requiring additional support for any other reason. Any kerb ramps, handrails or tactile stickers will comply with the Institute of Public Works Engineering Australasia (IPWEA) design standards.

This program can be revised and reviewed annually, or at any time, for possible changes in line with community needs, unforeseen priorities and financial availability or restraints.

Voting Requirements

Simple Majority

OFFICERS' RECOMMENDATION

That Council adopt the revised Ten Year Footpath Construction Program 2021-2031 as presented at Attachment 1.

PROPOSED 10 YEAR FOOTPATH CONSTRUCTION PROGRAM 2021-2031

Road	Description	Length M	Width M	Area M2	Comments	Year	Location Total	Total Annual Cost	
Ensign Street	Narrakine to Daghish	420	1.8	756	On North side of Ensign includes 2 kerb ramps	2021/22	\$46,200.00	\$46,200.00	
Doney Street	Butler to Gray	181	1.8	325	On South side of Doney includes 2 kerb ramps	2022/23	\$19,910.00	\$44,990.00	
Burns Street	Kipling to Doney	228	1.8	410	On East side of Burns includes 2 kerb ramps		\$25,080.00		
Ensign Street	Narrakine to Floyed	310	1.8	558	On North side of Ensign includes 2 kerb ramps	2023/24	\$34,100.00	\$49,500.00	
Daghish Street	Lock to Ensign	140	1.8	234	On West side of Daghish, remove old chip seal, includes 2 kerb ramp		\$15,400.00		
Butler Street	Homer to adjoining H/School bus stop	132	1.8	252	On East side of Butler, removal old concrete slabs	2024/25	\$14,520.00	\$43,120.00	
Homer Street	Butler to Argus	130	1.8	234	On South side of Homer, remove old chip seal and install 3 kerb ramps		\$14,300.00		
Falcon Street	Federal to Glyde	130	1.8	782	On North side of Falcon includes removal of chip seal, concrete slabs and install 3 kerb ramps		\$14,300.00		
Gray Street	Kipling to Doney	434	1.8	297	On East side of Gray includes removal of chip seal	2025/26	\$47,740.00	\$47,740.00	
Butler Street	Doney to Hansard	130	1.8	234	On East side of Butler Street includes 1 kerb ramp	2026/27	\$14,300.00	\$51,700.00	
Daghish Street	Ensign to Clayton	340	1.8	234	On West side of Daghish, remove old chip seal and includes 1 kerb ramp		\$37,400.00		
Forrest Street	82 Forrest to Narrakine	340	1.8	612	On Northern side crossing to southern side of Forrest including earthworks and install 3 kerb ramps	2027/28	\$37,400.00	\$57,420.00	
Falcon Street	Glyde to Johnson	182	1.8	328	On North side of Falcon remove chip seal and install 2 kerb ramps		\$20,020.00		
Falcon Street	Johnson to Floreat to Furnival	332	1.8	598	On South side of Falcon, continue on east side of Floreat, install 3 kerb ramps	2028/29	\$36,520.00	\$67,320.00	
Narrakine Road	Furnival to Felspar	280	1.8	504	On East side of Narrakine to join Furnival to Felspa		\$30,800.00		
Fox Street	Gordon to Garfield	376	1.8	677	On South side of road	2029/30	\$41,360.00	\$41,360.00	
Northwood Street	Gordon to Garfield	326	1.8	587	On South side of road	2030/31	\$35,860.00	\$59,730.00	
Forrest Street	Federal to Earl	217	1.8	391	Remove failed asphalt on North side and renew with concrete		\$23,870.00		
Homer Street	Havelock Argus and Butler to Gray	490	1.8	882	Remove failed asphalt on South side and renew with concrete	2031/32	\$53,900.00	\$53,900.00	
Average Annual Total							\$51,180.00	\$562,980.00	\$562,980.00
							TOTAL	\$562,980.00	\$562,980.00

PROPOSED 10 YEAR FOOTPATH CONSTRUCTION PROGRAM 2021 -2031



Footpaths proposed in the 10 year construction program ■

10.3 CORPORATE AND COMMUNITY SERVICES

10.3.1 SCHEDULE OF ACCOUNTS PAID – MAY 2021

File Reference	12.1.1
Disclosure of Interest	Neither the Author nor Authorising Officer have any Impartiality, Financial or Proximity Interest that requires disclosure.
Applicant	Shire of Narrogin
Previous Item Numbers	Nil
Date	9 June 2021
Author	Danielle Gannaway – Customer Service Officer/Accounts Payable
Authorising Officer	Frank Ludovico – Executive Manager Corporate & Community Services
Attachments	1. Schedule of Accounts Paid – May 2021 (separate cover).

Summary

Council is requested to note the payments as presented in the Schedule of Accounts Paid – May 2021.

Background

Pursuant to Local Government Act 1995, Section 6.8 (2)(b), where expenditure has been incurred by a local government, it is to be reported to the next Ordinary Meeting of Council.

Consultation

Manager Corporate Services

Statutory Environment

Local Government Act 1995, Section 6.8 (2)(b).

Policy Implications

Nil

Financial Implications

All expenditure has been approved via adoption of the 2020/2021 Annual Budget, or resulting from a Council resolution for a budget amendment.

Strategic Implications

Shire of Narrogin Strategic Community Plan 2017-2027	
Objective	4. Civic Leadership Objective (Continually enhance the Shire's organisational capacity to service the needs of a growing community)
Outcome:	4.1 An efficient and effective organisation

Comment/Conclusion

The Schedule of Accounts Paid – May 2021 is presented to Council for notation. Below is a summary of activity.

<i>May 2021 Payments</i>		
<i>Payment Type</i>	<i>\$</i>	<i>%</i>
Cheque	0.00	0.00
EFT (incl Payroll)	1,136,079.83	81.80
Direct Debit	247,164.32	17.80
Credit Card	5,499.46	0.40
Trust		
Total Payments	1,388,743.61	100.00

<i>Local Spending</i>	<i>\$</i>	<i>%</i>
Local Suppliers	277,150.01	19.95
Payroll	306,865.15	22.10
Total	584,015.16	42.05

Voting Requirements

Simple Majority.

OFFICERS' RECOMMENDATION

That, with respect to the Schedule of Accounts Paid for May 2021, Council note the Report as presented.

Cheque Payments

Chq/EFT/DD	Date	Name	Description	Invoice Amount	Payment Total	Type	Funding
Cheque Total \$					-		

EFT Payments

Chq/EFT	Date	Name	Description	Invoice Amount	Payment Total	Type	Funding
2	EFT16332	07/05/2021	Narrogin Packaging		\$ 1,009.87	L	
3	INV 00069944	21/04/2021	Narrogin Packaging	VARIOUS PUBLIC TOILETS - Cleaning Supplies	\$ 59.70		
4	INV 00069901	24/04/2021	Narrogin Packaging	VARIOUS PUBLIC TOILETS - Cleaning Supplies	\$ 556.02		
5	INV 00069985	29/04/2021	Narrogin Packaging	VARIOUS PUBLIC TOILETS - Cleaning Supplies	\$ 394.15		
6	EFT16333	07/05/2021	Great Southern Fuels		\$ 549.86	L	
7	INV B26097-D2063069	22/04/2021	Great Southern Fuels	SMALL PLANT - 400L Unleaded Petrol	\$ 549.86		
8	EFT16334	07/05/2021	Narrogin Fruit Market		\$ 930.10	L	
9	INV 00032021040632	06/04/2021	Narrogin Fruit Market	MEMBERS CIVIC FUNCTIONS, REFRESHMENTS & RECEPTIONS - Hi-Lo & Full Cream Milk	\$ 8.60		
10	INV 00042021040731	07/04/2021	Narrogin Fruit Market	MEMBERS CIVIC FUNCTIONS, REFRESHMENTS & RECEPTIONS - Full Cream Milk x2	\$ 8.60		
11	INV 00032021041224	12/04/2021	Narrogin Fruit Market	MEMBERS CIVIC FUNCTIONS, REFRESHMENTS & RECEPTIONS - Hi-Lo & Full Cream Milk	\$ 8.60		
12	INV 00032021041624	16/04/2021	Narrogin Fruit Market	MEMBERS CIVIC FUNCTIONS, REFRESHMENTS & RECEPTIONS - Full Cream Milk	\$ 4.30		
13	INV 0008202104181	18/04/2021	Narrogin Fruit Market	MEMBERS - CIVIC FUNCTIONS, REFRESHMENTS & RECEPTIONS - Catering for Council Meeting 14/04/2021	\$ 450.00		
14	INV 0008202104292	29/04/2021	Narrogin Fruit Market	MEMBERS - CIVIC FUNCTIONS, REFRESHMENTS & RECEPTIONS - Catering for Council Meeting 28/04/2021	\$ 450.00		

	Chq/EFT/DD	Date	Name	Description	Invoice Amount	Payment Total	Type	Funding
15	EFT16335	07/05/2021	Makit Narrogin Hardware			\$ 4,320.66	L	
16	INV 113476	03/03/2021	Makit Narrogin Hardware	VARIOUS DEPARTMENTS - General Materials	\$ 827.00			
17	INV 113482	04/03/2021	Makit Narrogin Hardware	VARIOUS DEPARTMENTS - General Materials	\$ 70.40			
18	INV 113507	13/03/2021	Makit Narrogin Hardware	VARIOUS DEPARTMENTS - General Materials	\$ 204.71			
19	INV 113534	24/03/2021	Makit Narrogin Hardware	VARIOUS DEPARTMENTS - General Materials	\$ 1,977.90			
20	INV 113544	30/03/2021	Makit Narrogin Hardware	FOXES LAIR - Washers & Bolts x 24	\$ 78.00			
21	INV 113564	06/04/2021	Makit Narrogin Hardware	VARIOUS DEPARTMENTS - General Materials	\$ 343.70			
22	INV 113562	06/04/2021	Makit Narrogin Hardware	VARIOUS DEPARTMENTS - General Materials	\$ 392.15			
23	INV 113605	20/04/2021	Makit Narrogin Hardware	VARIOUS DEPARTMENTS - General Materials	\$ 426.80			
24	EFT16336	07/05/2021	Hancocks Home Hardware			\$ 89.75	L	PF
25	INV 360662	22/04/2021	Hancocks Home Hardware	CHSP SOCIAL SUPPORT GROUP OTHER EXPENSES - Door lock for Mens's Shed (Jessie House)	\$ 44.50			
26	INV 360655	22/04/2021	Hancocks Home Hardware	HACC - GENERAL OFFICE EXPENSES - Raid Control Bombs 3 Pack (Jessie House)	\$ 19.75			
27	INV 361421	30/04/2021	Hancocks Home Hardware	TOWN HALL (FEDERAL ST) BUILDING MAINTENANCE - Gecko Grip Tape & Set of Keys Cut	\$ 25.50			
28	EFT16337	07/05/2021	Narrogin Newsagency			\$ 91.70	L	
29	INV 1355 - 281545	01/05/2021	Narrogin Newsagency	LIB - SUBSCRIPTIONS & MEMBERSHIPS - Deliveries for the Period 01/04/2021-29/04/2021	\$ 91.70			
30	EFT16338	07/05/2021	Narrogin Electrical Services			\$ 2,783.00	L	
31	INV 2301	28/04/2021	Narrogin Electrical Services	CARAVAN PARK TRANSPORTABLE RESIDENCE BUILDING MAINTENANCE - Supply & Install New Air Conditioner	\$ 2,783.00			
32	EFT16339	07/05/2021	S. Williams Plumbing			\$ 845.00	L	
33	INV 299	29/04/2021	S. Williams Plumbing	VARIOUS PUBLIC TOILETS - Repairs & Maintenance	\$ 845.00			
34	EFT16340	07/05/2021	Borgas Engineering Pty Ltd			\$ 4,854.85	L	
35	INV 8562	30/04/2021	Borgas Engineering Pty Ltd	NO2731 FOUR AXLE SIDE TIPPER TRAILER & NO2706 FOUR AXLE SIDE TIPPER TRAILER - Repairs Cracks in Welds over Whole Trailer	\$ 4,582.60			
36	INV 8562	30/04/2021	Borgas Engineering Pty Ltd	CLAYTON ROAD OVAL MAINTENANCE/OPERATIONS - Installation of Goal Posts	\$ 272.25			

	Chq/EFT/DD	Date	Name	Description	Invoice Amount	Payment Total	Type	Funding
37	EFT16341	07/05/2021	Narrogin Bearing Service			\$ 550.00	L	
38	INV IN185617	27/04/2021	Narrogin Bearing Service	ROADM - WORKSHOP/DEPOT EXPENSED EQUIPMENT - Drum Pump x2	\$ 550.00			
39	EFT16342	07/05/2021	RJ Smith Engineering			\$ 76.45	L	
40	INV 00012926	28/04/2021	RJ Smith Engineering	NO4792 2012 DYNAPAC PAD FOOT ROLLER - Supply Drivers Side Door Stay	\$ 35.20			
41	INV 00012977	30/04/2021	RJ Smith Engineering	PWO - WORKS - PROTECTIVE CLOTHING - Safety glasses x1 & Ear Muffs x1	\$ 41.25			
42	EFT16343	07/05/2021	PFD Food Services Pty Ltd			\$ 95.70		
43	INV KY214918	28/04/2021	PFD Food Services Pty Ltd	CARAVAN PARK GENERAL MAINTENANCE/OPERATIONS - 15ml Conditioner (Carton)	\$ 95.70			
44	EFT16344	07/05/2021	Octave Holdings Pty Ltd T/A Narrogin Toyota			\$ 128.70	L	
45	INV JC24029256	29/04/2021	Octave Holdings Pty Ltd T/A Narrogin Toyota	NGN417 2020 MAZDA BT-50 4x4 - Diagnose & Repair MIL Light on Dash	\$ 128.70			
46	EFT16345	07/05/2021	Goodyear Dunlop Tyres Pty Ltd (Beaurepaires)			\$ 160.18	L	
47	INV 6411981310	27/04/2021	Goodyear Dunlop Tyres Pty Ltd (Beaurepaires)	032NGN 2020 MAZDA CX3 MAXX SPORT - New Tyre	\$ 135.18			
48	INV 6411985532	29/04/2021	Goodyear Dunlop Tyres Pty Ltd (Beaurepaires)	NO01 2019 HOLDEN COLORADO - Puncture Repair	\$ 25.00			
49	EFT16346	07/05/2021	Watershed News Incorporated			\$ 330.00	L	F
50	INV 00000414	08/02/2021	Watershed News Incorporated	CHSP - ADVERTISING & PROMOTIONS - Full Page Advertising - Fortnightly from 08/02/2021-28/06/2021	\$ 330.00			
51	EFT16347	07/05/2021	John Parry Medical Centre			\$ 126.00	L	F
52	INV 401352	22/04/2021	John Parry Medical Centre	CHSP - RECRUITMENT - Pre-Employment Medical for Carol Holloway	\$ 126.00			
53	EFT16348	07/05/2021	Lr Sims & Co			\$ 555.00	L	F
54	INV IV00000000290	22/02/2021	Lr Sims & Co	CHCP - CLIENT PURCHASES - Front Step Edge (Client: P. Hoggard)	\$ 555.00			
55	EFT16349	07/05/2021	Belvedere Nursery			\$ 50.00	L	
56	INV I0000001797	29/04/2021	Belvedere Nursery	MEMORIAL PARK MAINTENANCE/OPERATIONS - 1/2m3 Garden Mix	\$ 50.00			
57	EFT16350	07/05/2021	Traffic Force			\$ 2,475.42		
58	INV 00024034	25/04/2021	Traffic Force	OTHCUL - EVENT TRAFFIC MANAGEMENT - ANZAC Day TMP (4 Person Crew & Vehicle)	\$ 2,475.42			

	Chq/EFT/DD	Date	Name	Description	Invoice Amount	Payment Total	Type	Funding
59	EFT16351	07/05/2021	Fulton Hogan			\$ 56,244.94		F
60	INV 15114051 RI	29/04/2021	Fulton Hogan	NARRAKINE ROAD - Renewal (R2R) - Variation - 2 Coat Seal (10mm/7mm)	\$ 56,244.94			
61	EFT16352	07/05/2021	Easifleet			\$ 2,773.37		
62	INV 280421	28/04/2021	Easifleet	NOVATED LEASE - Employee Expenses PPE 28/04/2021	\$ 2,773.37			
63	EFT16353	07/05/2021	Rylan Pty Ltd			\$ 3,300.00		
64	INV 2283	29/03/2021	Rylan Pty Ltd	NRLC - INFRASTRUCTURE OTHER (CAPITAL - OUTSIDE) - Kerbing Installation (Day Rate)	\$ 3,300.00			
65	EFT16354	07/05/2021	Salvation Army (WA)			\$ 463.64	L	
66	INV I000138400	21/04/2021	Salvation Army (WA)	OTHCUL - CAROLS BY CANDLELIGHT - Reimbursement - Carols in the Park December 2020	\$ 463.64			
67	EFT16355	07/05/2021	Lotex Filter Cleaning Service			\$ 248.28		
68	INV 00006867	18/03/2021	Lotex Filter Cleaning Service	POC - PARTS & REPAIRS - Filter Cleaning - March 2021	\$ 248.28			
69	EFT16356	07/05/2021	Cutting Edges			\$ 453.22		
70	INV 3301355	27/04/2021	Cutting Edges	NO4871 2014 JOHN DEERE 670G GRADER w/ TOP CON & NO4719 2012 JOHN DEERE 670G GRADER - Tooth Scarifier x54	\$ 453.22			
71	EFT16357	07/05/2021	Total Quality Clean			\$ 462.00	L	
72	INV 3233	01/01/2021	Total Quality Clean	TOWN HALL (FEDERAL ST) BUILDING MAINTENANCE - Upholstery Cleaning to Chairs (Mayors Parlour)	\$ 462.00			
73	EFT16358	07/05/2021	AFGRI Equipment Australia Pty Ltd			\$ 1,948.16	L	
74	INV 2008427	10/03/2021	AFGRI Equipment Australia Pty Ltd	2017 JOHN DEERE RIDE ON MOWER - V-Belt x2 & Deck Wheels x4	\$ 241.78			
75	INV 2008351	10/03/2021	AFGRI Equipment Australia Pty Ltd	JOHN DEERE RIDE ON MOWER JD130 - Blower Attachment, Blade x6 & Freight	\$ 1,253.99			
76	INV 2012432	25/03/2021	AFGRI Equipment Australia Pty Ltd	NGN390 2004 JOHN DEERE TRACTOR - Oil, Air and Fuel Filters for Service	\$ 364.39			
77	INV 2017304	13/04/2021	AFGRI Equipment Australia Pty Ltd	2017 JOHN DEERE RIDE ON MOWER - Service Kit	\$ 88.00			
78	EFT16359	07/05/2021	Corsign (WA) Pty Ltd			\$ 110.00		
79	INV 00055841	22/04/2021	Corsign (WA) Pty Ltd	GNARAJIN PARK PUBLIC TOILETS MAINTENANCE - Supply of Toilet Signs & Freight	\$ 110.00			
80	EFT16360	07/05/2021	Dx Print Group			\$ 396.00		
81	INV 00094320	15/04/2021	Dx Print Group	ADMIN - PRINTING & STATIONERY - Business Cards (Engineering Technical Officer, Planning Officer, Manager Corporate Services & Senior Environmental Health Officer)	\$ 396.00			

	Chq/EFT/DD	Date	Name	Description	Invoice Amount	Payment Total	Type	Funding
82	EFT16361	07/05/2021	Firey Productions			\$ 264.00		
83	INV INV-2365	29/04/2021	Firey Productions	MEMBERS - ADVERTISING & PROMOTIONS - Reclassificaion of 2 x 15sec Commercials produced in 2017 for WIN Network. (FIRBU832515 & FIRBU832815)	\$ 264.00			
84	EFT16362	07/05/2021	Regional Communication Solutions			\$ 429.00	L	F
85	INV INV-1198	23/04/2021	Regional Communication Solutions	CHSP - INFORMATION SYSTEMS - Supply & Install WIFI Router	\$ 429.00			
86	EFT16363	07/05/2021	Sherrin Rentals Pty Ltd			\$ 3,080.00		
87	INV 5154804	30/04/2021	Sherrin Rentals Pty Ltd	NARROGIN VALLEY ROAD - RENEWAL (RURAL) - 10 Day Water Cart Hire	\$ 3,080.00			
88	EFT16364	07/05/2021	BT Equipment Pty Ltd T/As Tutt Bryant Equipment			\$ 44,000.00		
89	INV 008022625	27/04/2021	BT Equipment Pty Ltd T/As Tutt Bryant Equipment	Purchase of New BW120AD - 5 Tandem Vibratory Bomag Roller & Disposal of 2002 Bomag Twin Vibrating Roller	\$ 44,000.00			
90	EFT16365	07/05/2021	New Ground Water Services Pty Ltd			\$ 97,377.50		
91	INV 1001427	30/04/2021	New Ground Water Services Pty Ltd	TWIS DAMS - Supply & Install New Effluent Line (as per RFQ20/21-13) (Claim 1)	\$ 97,377.50			
92	EFT16366	07/05/2021	Wheatbelt Hydrology			\$ 11,603.53	L	
93	INV NARSWMP-02	23/04/2021	Wheatbelt Hydrology	CLAYTON ROAD STORM WATER CATCHMENT DAM & GNARAJIN PARK HYDROLOGY REPORT - Hydrology Consultancy (RFQ 19/20-07)	\$ 11,603.53			
94	EFT16367	07/05/2021	Melbourne Barbeque Centre			\$ 647.90		
95	INV A9477	28/04/2021	Melbourne Barbeque Centre	YILLIMINNING ROCK - Replacement BBQ Pieces & Freight	\$ 647.90			
96	EFT16368	07/05/2021	ASSA ABLOY Australia Pty Limited			\$ 4,037.03		
97	INV IN01940011	20/04/2021	ASSA ABLOY Australia Pty Limited	VARIOUS BUILDINGS - Keys to Suit Master Key System 6437	\$ 185.96			
98	INV IN01941670	21/04/2021	ASSA ABLOY Australia Pty Limited	VARIOUS BUILDINGS - Keys, Padlocks & Barrels to Suit Master Key System 6437	\$ 1,019.50			
99	INV IN01945127	27/04/2021	ASSA ABLOY Australia Pty Limited	FIRE PREVENTION/BURNING/CONTROL - Padlocks for Fire Gates x30 & Keys for Fire Gate Locks x5	\$ 2,831.57			
100	EFT16369	07/05/2021	MC & SP Russell			\$ 535.51	L	PF
101	INV 03/21	28/04/2021	MC & SP Russell	RAILWAY STATION RESTORATION COVID RECOVERY PROJECT - Model Train Display - Reimbursement of Materials Costs	\$ 535.51			
102	EFT16370	07/05/2021	Express Hiab Service Pty Ltd			\$ 1,106.60		
103	INV X1185	23/04/2021	Express Hiab Service Pty Ltd	STREET TREE MAINTENANCE - Freight Charges for Trees x6	\$ 1,106.60			

	Chq/EFT/DD	Date	Name	Description	Invoice Amount	Payment Total	Type	Funding
104	EFT16371	07/05/2021	Lighting Options Australia			\$ 5,067.32		
105	INV INV/2021/0141	29/04/2021	Lighting Options Australia	OTHCUL - INFRASTRUCTURE OTHER (CAPITAL) - 50% Down Payment - Lights & Tracks for NEXIS Gallery	\$ 5,067.32			
106	PAYROLL 23	10/05/2021	PAYROLL	Payroll 23 - 10/05/2021	\$ 150,597.96			
107	EFT16372	13/05/2021	Best Office Systems			\$ 1,131.36	L	PF
108	INV 586648	27/04/2021	Best Office Systems	VARIOUS DEPARTMENTS - Photocopier Charges (20/03/2021-20/04/2021)	\$ 1,131.36			
109	EFT16373	13/05/2021	Coles			\$ 492.07	L	PF
110	INV 170	30/04/2021	Coles	VARIOUS DEPARTMENTS - Coles April 2021	\$ 492.07			
111	EFT16374	13/05/2021	Synergy			\$ 11,930.47		
112	INV 6499184328	03/05/2021	Synergy	ROADM - STREET LIGHTING MAINTENANCE/OPERATIONS - Electricity Usage (25/03/2021-24/04/2021)	\$ 11,930.47			
113	EFT16375	13/05/2021	Narrogin Packaging			\$ 280.00	L	F
114	INV 00069582	24/03/2021	Narrogin Packaging	CHSP HOME MAINTENANCE OTHER EXPENSES - Set of Ramps (To access Home Maintenance Trailer)	\$ 280.00			
115	EFT16376	13/05/2021	Australia Post			\$ 352.80	L	PF
116	INV 1010547520	03/05/2021	Australia Post	VARIOUS DEPARTMENTS - Postal Charges April 2021	\$ 352.80			
117	EFT16377	13/05/2021	Great Southern Fuels			\$ 5,229.52	L	PF
118	INV APRIL 2021	30/04/2021	Great Southern Fuels	VARIOUS PLANT & EQUIPMENT - Fuel Card Charges April 2021	\$ 5,229.52			
119	EFT16378	13/05/2021	Knightline Computers			\$ 309.00	L	F
120	INV 00072747	11/03/2021	Knightline Computers	CHSP - INFORMATION SYSTEMS - Powersheid Defender 1200VA	\$ 309.00			
121	EFT16379	13/05/2021	Parry's Pty Ltd			\$ 407.90	L	
122	INV 52949	12/04/2021	Parry's Pty Ltd	ANIMAL - PROTECTIVE CLOTHING - Jumper x2 & Boots x1 (G. Maley)	\$ 237.90			
123	INV 53405	28/04/2021	Parry's Pty Ltd	PWO - WORKS - PROTECTIVE CLOTHING - Jumper x1 (C. Williams)	\$ 42.50			
124	INV 53421	28/04/2021	Parry's Pty Ltd	PWO - WORKS - PROTECTIVE CLOTHING - Pants x2 & Shirts x2 (A. Colson)	\$ 153.90			
125	INV ADJ 53422	28/04/2021	Parry's Pty Ltd	PWO - WORKS - PROTECTIVE CLOTHING - Pants x2 & Shirts x2 (A. Colson) (Adjustment - Embroidery)	\$ (26.40)			

	Chq/EFT/DD	Date	Name	Description	Invoice Amount	Payment Total	Type	Funding
126	EFT16380	13/05/2021	Anderson Munro & Wyllie			\$ 1,540.00		
127	INV I002514	30/04/2021	Anderson Munro & Wyllie	OTHGOV - AUDIT FEES - Preparation of Audit Documents (2017/18 & 2018/19 Deferred Pensioner Certificate)	\$ 1,540.00			
128	EFT16381	13/05/2021	Narrogin Meals On Wheels			\$ 424.70	L	F
129	INV 100896	08/04/2021	Narrogin Meals On Wheels	CHSP MEALS ON WHEELS COMMITTEE - Meal Delivery Services March 2021	\$ 424.70			
130	EFT16382	13/05/2021	Narrogin Electrical Services			\$ 29,896.63	L	PF
131	INV 2309	05/05/2021	Narrogin Electrical Services	RAILWAY STATION RESTORATION COVID RECOVERY PROJECT - Supply & Install Electrical Refit Materials (85% Pre-Payment)	\$ 29,896.63			
132	EFT16383	13/05/2021	It Vision			\$ 5,964.75		
133	INV 35083	30/04/2021	It Vision	ADMIN - INFORMATION SYSTEMS - Implementation & Training Services for Altus Bank Reconciliation Module	\$ 5,964.75			
134	EFT16384	13/05/2021	Great Southern Waste Disposal			\$ 51,786.54	L	
135	INV IV00000001593	06/05/2021	Great Southern Waste Disposal	BIN COLLECTIONS VARIOUS LOCATIONS - April 2021	\$ 51,786.54			
136	EFT16385	13/05/2021	Super Civil Pty Ltd			\$ 58,976.28		
137	INV INV-0126	22/04/2021	Super Civil Pty Ltd	RAILWAY STATION RESTORATION COVID RECOVERY PROJECT - Supply & Install Asphalt to Train Station Carpark	\$ 39,925.38			
138	INV INV-0126	22/04/2021	Super Civil Pty Ltd	ROAD MAINTENANCE GENERAL EXPENSES - Additional Profiling & Asphalt to Train Station Carpark	\$ 19,050.90			
139	EFT16386	13/05/2021	Air Response			\$ 100.00	L	F
140	INV 1488.11A	13/04/2021	Air Response	CHSP - GENERAL OFFICE EXPENSES - Service Ducted Air Conditioners (Jessie House)	\$ 100.00			
141	EFT16387	13/05/2021	Lane Buck And Higgins			\$ 314.25	L	
142	INV A278800	10/05/2021	Lane Buck And Higgins	Rates refund for assessment A278800 91A Narrakine Road NARROGIN WA 6312	\$ 314.25			
143	EFT16388	13/05/2021	Farmers Centre (Narrogin) Pty Ltd			\$ 246.69	L	
144	INV 78500	27/04/2021	Farmers Centre (Narrogin) Pty Ltd	2019 JCB 5CX BACKHOE LOADER - 20L Hydraulic Oil x2	\$ 246.69			
145	EFT16389	13/05/2021	Narrogin Chamber Of Commerce			\$ 2,500.00	L	
146	INV 00003797	03/05/2021	Narrogin Chamber Of Commerce	TOUR - PUBLIC RELATIONS & AREA PROMOTION - \$10 Gift Vouchers x250 (Caravan Park)	\$ 2,500.00			

	Chq/EFT/DD	Date	Name	Description	Invoice Amount	Payment Total	Type	Funding
147	EFT16390	13/05/2021	Marketforce Pty Ltd			\$ 617.40		
148	INV 38396	27/04/2021	Marketforce Pty Ltd	ADMIN - RECRUITMENT - Advertising Position - (Customer Service Officer) Narrogin Observer 15/04/2021	\$ 308.70			
149	INV 38395	27/04/2021	Marketforce Pty Ltd	ADMIN - RECRUITMENT - Advertising Position - (Caravan Park Attendant Casual) - Narrogin Observer 01/04/2021	\$ 308.70			
150	EFT16391	13/05/2021	Melchiorre Plumbing & Gas			\$ 99.00	L	F
151	INV 7590	13/04/2021	Melchiorre Plumbing & Gas	CHSP - GENERAL OFFICE EXPENSES - Labour - Fix Tap Washers (Jessie House)	\$ 99.00			
152	EFT16392	13/05/2021	West Australian Newspapers Limited			\$ 840.00		
153	INV 1028037520210430	30/04/2021	West Australian Newspapers Limited	OTHFUL - ANZAC DAY - Advertising - Narrogin Observer 22/04/2021	\$ 180.00			
154	INV 1028037520210430	30/04/2021	West Australian Newspapers Limited	MEMBERS - ADVERTISING & PROMOTIONS - Full Page Newsletter - Narrogin Narrative April 2021	\$ 660.00			
155	EFT16393	13/05/2021	Broad Electrical And Air Conditioning			\$ 180.40	L	F
156	INV IV775	27/04/2021	Broad Electrical And Air Conditioning	CHCP - CLIENT PURCHASES - Install Weatherproof GPO for New Hot Water System (Client: W. Thorpe)	\$ 180.40			
157	EFT16394	13/05/2021	Fulton Hogan			\$ 127,085.11		
158	INV 15114053 RI	29/04/2021	Fulton Hogan	VARIOUS ROADS & STREETS - Reseal	\$ 105,154.04			F
159	INV 15114055 RI	29/04/2021	Fulton Hogan	MOSS STREET - UPGRADE (LOCAL) - 10mm Primer Seal & 7mm Second Seal	\$ 21,931.07			
160	EFT16395	13/05/2021	Narrogin Furnishings			\$ 1,999.00	L	F
161	INV 00113612	19/04/2021	Narrogin Furnishings	CHCP - CLIENT PURCHASES - Ultra Luxury King Mattress (Client: E Chaplin)	\$ 1,999.00			
162	EFT16396	13/05/2021	YMCA WA			\$ 48,261.11	L	
163	INV SI-A010308	22/04/2021	YMCA WA	NRLC BUILDING (CAPITAL) - Reimbursement for Repairs & Upgrades to Narrogin Leisure Centre CCTV System	\$ 13,950.31			
164	INV SI-A010360	30/04/2021	YMCA WA	NRLC - CONTRACT MANAGEMENT EXPENSE - YMCA Management Fee April 2021 & Actual Deficit for March 2021	\$ 34,141.80			
165	INV SI-A010344	30/04/2021	YMCA WA	ADMIN - OCCUPATIONAL HEALTH & SAFETY - 3 Month Gym Membership for Alexander Mulenga (30/04/2021-29/07/2021)	\$ 169.00			
166	EFT16397	13/05/2021	Truck Centre (WA) Pty Ltd			\$ 7,141.89		
167	INV 2220391-00001	05/05/2021	Truck Centre (WA) Pty Ltd	NO4 2010 NISSAN UD TIP TRUCK AUTO - Repair Oil Leak in back of Engine, Replace Pin & Bushes on Front Springs	\$ 5,981.72			
168	INV 1633057-000001	05/05/2021	Truck Centre (WA) Pty Ltd	NO2 2009 NISSAN UD TIP TRUCK - Filter kit for Next Service & Heater A/C Motor Fan	\$ 1,160.17			

	Chq/EFT/DD	Date	Name	Description	Invoice Amount	Payment Total	Type	Funding
169	EFT16398	13/05/2021	Heritage Intelligence (WA)			\$ 9,350.00		PF
170	INV NGN 21/1	22/04/2021	Heritage Intelligence (WA)	RAILWAY STATION BUILDING (CAPITAL) - Conservation Management Plan - Final Phase: Narrogin Railway Station & Goods Sheds, Conservation Management Plan, Re-Use	\$ 9,350.00			
171	EFT16399	13/05/2021	Telair Pty Ltd			\$ 1,474.70		PF
172	INV TA10781-022	30/04/2021	Telair Pty Ltd	VARIOUS DEPARTMENTS - Telephone Charges April 2021	\$ 1,474.70			
173	EFT16400	13/05/2021	Kulker Carpentry And Construction			\$ 15,950.00	L	PF
174	INV IV00000000505	07/05/2021	Kulker Carpentry And Construction	RAILWAY STATION RESTORATION COVID RECOVERY PROJECT - Supply & Install Galvanised Roof Sheeting to Train Station & Toilet Block Roofs (Pre-Payment for Materials)	\$ 15,950.00			
175	EFT16401	13/05/2021	Narrogin Fresh			\$ 447.76	L	PF
176	INV MARCH (3)	29/03/2021	Narrogin Fresh	VARIOUS DEPARTMENTS - Narrogin Fresh Account March (3) 2021	\$ 220.03			
177	INV APRIL 2021	09/04/2021	Narrogin Fresh	CHSP SOCIAL SUPPORT GROUP OTHER EXPENSES - Homecare Account April 2021	\$ 227.73			
178	EFT16402	13/05/2021	Narrogin Florist			\$ 35.00	L	
179	INV INV199	04/05/2021	Narrogin Florist	MEMBERS - CIVIC FUNCTIONS, REFRESHMENTS & RECEPTIONS - Flowers - Wedding Celebration (T. Nicholls)	\$ 35.00			
180	EFT16403	13/05/2021	Surgical House Pty Ltd			\$ 5,347.81		F
181	INV A722531	07/10/2020	Surgical House Pty Ltd	CHCP - CLIENT PURCHASES - Various Items & Freight	\$ 731.95			
182	INV A727820	13/11/2020	Surgical House Pty Ltd	CHCP - CLIENT PURCHASES - Various Items & Freight (Client: J. Manning)	\$ 947.30			
183	INV A729892	27/11/2020	Surgical House Pty Ltd	CHCP - CLIENT PURCHASES - Wheelchair Folding Transit Escape Lite & Freight (Client:R. Broun)	\$ 329.20			
184	INV A73298	17/12/2020	Surgical House Pty Ltd	CHCP - CLIENT PURCHASES - Curas Fluid Absorber Sap 6G Sachet x100 & Urinal Male Bottle Pulp x120	\$ 159.90			
185	INV A737476	25/01/2021	Surgical House Pty Ltd	CHCP - CLIENT PURCHASES - Various Items & Freight	\$ 554.80			
186	INV A741983	24/02/2021	Surgical House Pty Ltd	CHCP - CLIENT PURCHASES - Medical Stock for Dressings & Freight	\$ 1,415.67			
187	INV A743472	09/03/2021	Surgical House Pty Ltd	CHCP - CLIENT PURCHASES - Shower Chair with Arms, Floor Mat & Freight (Client: E Neil-Smith)	\$ 304.00			
188	INV A743384	09/03/2021	Surgical House Pty Ltd	CHCP - CLIENT PURCHASES - Betadine Antiseptic x2 & Surgical Tape	\$ 74.05			
189	INV A743479	09/03/2021	Surgical House Pty Ltd	CHCP - CLIENT PURCHASES - Bandages, Dressings & Medical Lubricant & Freight	\$ 830.94			
190	EFT16404	13/05/2021	Alexander Mulenga			\$ 2,343.19		
191	INV 230421	23/04/2021	Alexander Mulenga	ADMIN - RECRUITMENT - Reimbursement - 50% of Removal Costs (Per Employment Contract)	\$ 2,343.19			

	Chq/EFT/DD	Date	Name	Description	Invoice Amount	Payment Total	Type	Funding
192	EFT16405	13/05/2021	Smart Digital Australia Pty Ltd			\$ 964.70		
193	INV INV-1526	03/05/2021	Smart Digital Australia Pty Ltd	OTHCUL - AUSTRALIA DAY - Replacement Speakers for Cinema Package x2	\$ 964.70			
194	EFT16406	13/05/2021	Shire of Mundaring			\$ 6,041.32		
195	INV 23328	20/04/2021	Shire of Mundaring	PROVISION FOR LONG SERVICE LEAVE (CURRENT) - Long Service Leave Recoup (T. Reitmajer)	\$ 6,041.32			
196	EFT16407	13/05/2021	David George Ingram			\$ 1,925.85	L	
197	INV A335900	06/05/2021	David George Ingram	Rates refund for assessment A335900 9 LYDEKER WAY NARROGIN WA 6312	\$ 1,925.85			
198	EFT16408	14/05/2021	Department Of Human Services			\$ 244.70		
199	INV DEDUCTION	10/05/2021	Department Of Human Services	Payroll deductions	\$ 244.70			
200	EFT16409	14/05/2021	Local Government Racing & Cemeteries Employees Union (LGREU)			\$ 20.50		
201	INV DEDUCTION	10/05/2021	Local Government Racing & Cemeteries Employees Union (LGREU)	Payroll deductions	\$ 20.50			
202	EFT16410	14/05/2021	Australian Services Union Western Australian Branc			\$ 25.90		
203	INV DEDUCTION	10/05/2021	Australian Services Union Western Australian Branc	Payroll deductions	\$ 25.90			
204	EFT16411	21/05/2021	Narrogin Hire & Reticulation			\$ 258.40	L	PF
205	INV 00029975	30/03/2021	Narrogin Hire & Reticulation	NRLC GROUNDS MAINTENANCE - Reticulation Materials	\$ 218.00			
206	INV 00030200	06/05/2021	Narrogin Hire & Reticulation	CHSP HOME MAINTENANCE OTHER EXPENSES - Hunter PGP Rotors	\$ 40.40			
207	EFT16412	21/05/2021	Narrogin Packaging			\$ 585.62	L	
208	INV 000070129	03/05/2021	Narrogin Packaging	HIGHBURY PUBLIC TOILETS OPERATIONS - Cleaning Supplies	\$ 126.35			
209	INV 70103	08/05/2021	Narrogin Packaging	VARIOUS PUBLIC TOILETS - Cleaning Supplies	\$ 459.27			
210	EFT16413	21/05/2021	Great Southern Fuels			\$ 770.00	L	
211	INV 19006633	06/05/2021	Great Southern Fuels	POC - FUELS AND OILS - 1000L ADBLUE	\$ 770.00			
212	EFT16414	21/05/2021	Water Corporation			\$ 368.65		
213	INV GKYB4	17/05/2021	Water Corporation	13 HOUGH ST - OPERATIONS - Water Usage (11/02/2021-01/04/2021)	\$ 368.65			

	Chq/EFT/DD	Date	Name	Description	Invoice Amount	Payment Total	Type	Funding
214	EFT16415	21/05/2021	Department Of Finance Shared Services State Library of WA			\$ 1,275.38		
215	INV R1028218	07/05/2021	Department Of Finance Shared Services State Library of WA	LIB - GENERAL OFFICE EXPENSES - Freight Recoup 2020-21	\$ 1,275.38			
216	EFT16416	21/05/2021	Hancocks Home Hardware			\$ 43.95	L	F
217	INV 362141	07/05/2021	Hancocks Home Hardware	HACC - GENERAL OFFICE EXPENSES - Film Poly Clear x 8	\$ 31.60			
218	INV 362517	12/05/2021	Hancocks Home Hardware	HACC - GENERAL OFFICE EXPENSES - Film Poly Clear & Ratsak Throwpack	\$ 12.35			
219	EFT16417	21/05/2021	Susan Farrell			\$ 50.00	L	
220	INV 035	11/05/2021	Susan Farrell	MEMBERS - CIVIC FUNCTIONS, REFRESHMENTS & RECEPTIONS - Various Ranges of Laundry	\$ 50.00			
221	EFT16418	21/05/2021	Westrac Pty Ltd			\$ 1,426.65		
222	INV PI 5738679	05/05/2021	Westrac Pty Ltd	NO4516 2013 CATERPILLAR CW34NN RUBBER TYRED ROLLER - Hose AS x2	\$ 622.86			
223	INV PI 5738680	05/05/2021	Westrac Pty Ltd	NO4516 2013 CATERPILLAR CW34NN RUBBER TYRED ROLLER - Air Filters x4	\$ 128.08			
224	INV PI 5742600	06/05/2021	Westrac Pty Ltd	1EVP731 2015 CAT SKID STEER LOADER - Filter x4	\$ 119.11			
225	INV PI 5742599	06/05/2021	Westrac Pty Ltd	NO4516 2013 CATERPILLAR CW34NN RUBBER TYRED ROLLER - Air Filters x4	\$ 319.40			
226	INV PI 5746936	07/05/2021	Westrac Pty Ltd	VARIOUS VEHICLES - Air On Run Hoses x5 & Freight	\$ 199.25			
227	INV PI 5753338	10/05/2021	Westrac Pty Ltd	NO237 2020 CATERPILLAR CW34NN RUBBER TYRED ROLLER - Air on Run Hose x1	\$ 37.95			
228	EFT16419	21/05/2021	Moore Stephens (WA) Pty Ltd			\$ 34,100.00		
229	INV 318657	06/10/2020	Moore Stephens (WA) Pty Ltd	ADMIN - CONSULTANTS - Assistance with Municipal Bank Reconciliations, Identification of Processing Issues & Ad Hoc Training on System (October 2019 - June 2020)	\$ 24,200.00			
230	INV 319975	28/01/2021	Moore Stephens (WA) Pty Ltd	ADMIN - CONSULTANTS - Assistance with Municipal Bank Reconciliations & Identification of Processing Issues (October 2019 - June 2020)	\$ 9,900.00			
231	EFT16420	21/05/2021	Narrogin Bearing Service			\$ 730.00	L	
232	INV IN186005	10/05/2021	Narrogin Bearing Service	ROADM - WORKSHOP/DEPOT EXPENSED EQUIPMENT - Nail Gun	\$ 730.00			

	Chq/EFT/DD	Date	Name	Description	Invoice Amount	Payment Total	Type	Funding
233	EFT16421	21/05/2021	RJ Smith Engineering			\$ 2,219.50	L	PF
234	INV 00013103	07/05/2021	RJ Smith Engineering	NGN390 2004 JOHN DEERE TRACTOR - Slasher Blade & Main Bar	\$ 1,933.80			
235	INV 00013135	07/05/2021	RJ Smith Engineering	SMALL PLANT - Bolts & Nuts	\$ 25.00			
236	INV 00013125	07/05/2021	RJ Smith Engineering	RAILWAY STATION RESTORATION COVID RECOVERY PROJECT - Angle Plates x 16 & 32mm Galvanised Pipe	\$ 237.60			
237	INV 00013226	11/05/2021	RJ Smith Engineering	ROADM - WORKSHOP/DEPOT EXPENSED EQUIPMENT - Solder x3 & Flux	\$ 23.10			
238	EFT16422	21/05/2021	Great Southern Towing			\$ 88.00	L	
239	INV 00008087	07/05/2021	Great Southern Towing	OLOPS - IMPOUNDED VEHICLES FEES - Towing of Abandoned Vehicle - Daglish St	\$ 88.00			
240	EFT16423	21/05/2021	Octave Holdings Pty Ltd T/A Narrogin Toyota			\$ 398.97	L	
241	INV PI23046021	12/05/2021	Octave Holdings Pty Ltd T/A Narrogin Toyota	SMALL PLANT - Handheld Blower	\$ 398.97			
242	EFT16424	21/05/2021	Goodyear Dunlop Tyres Pty Ltd (Beaurepaires)			\$ 58.95	L	
243	INV 6411998194	06/05/2021	Goodyear Dunlop Tyres Pty Ltd (Beaurepaires)	NO237 2020 CATERPILLAR CW34NN RUBBER TYRED ROLLER - Tyre Repair	\$ 58.95			
244	EFT16425	21/05/2021	Local Government Professionals Australia Wa			\$ 725.00		
245	INV 29794	13/05/2021	Local Government Professionals Australia Wa	ADMIN - TRAINING & DEVELOPMENT - CCTV Training for Local Government 10-11 June 2021 (K Sarma)	\$ 725.00			
246	EFT16426	21/05/2021	T Quip			\$ 96.20		
247	INV 101036 #7	11/05/2021	T Quip	1GPJ543 2018 TORO MOWER 7210 - Filters x4	\$ 96.20			
248	EFT16427	21/05/2021	Zipform			\$ 792.00		
249	INV 203380	30/04/2021	Zipform	TIP MAINTENANCE - Receipt Books x10 (5x Invoice To Be Raised & 5x Tax Invoice Receipt)	\$ 792.00			
250	EFT16428	21/05/2021	Australian Library & Information Association			\$ 165.00		
251	INV 00006938	18/03/2021	Australian Library & Information Association	LIB - SUBSCRIPTIONS & MEMBERSHIPS - Subscription to Online Storytime Pilot Program 2021	\$ 165.00			
252	EFT16429	21/05/2021	Market Creations Pty Ltd			\$ 1,244.20		
253	INV 16781	30/04/2021	Market Creations Pty Ltd	ADMIN - INFORMATION SYSTEMS - MC NBN Prem 100/40	\$ 198.00			
254	INV 16985	30/04/2021	Market Creations Pty Ltd	ADMIN - INFORMATION SYSTEMS - Setup on Configuration	\$ 330.00			
255	INV 16942	30/04/2021	Market Creations Pty Ltd	ADMIN - INFORMATION SYSTEMS - Service Desk & Preventative Maintenance (April 2021)	\$ 716.20			

	Chq/EFT/DD	Date	Name	Description	Invoice Amount	Payment Total	Type	Funding
256	EFT16430	21/05/2021	Food With Flair			\$ 375.00	L	
257	INV 6	11/08/2020	Food With Flair	MEMBERS - CIVIC FUNCTIONS, REFRESHMENTS & RECEPTIONS - Catering for MBS 11/08/2020	\$ 375.00			
258	EFT16431	21/05/2021	Gnarojin Community Garden			\$ 6,000.00	L	
259	INV 0017	15/04/2021	Gnarojin Community Garden	OTHCUL - OTHER EXPENDITURE - Annual Financial Contribution 2020/21 (As Per Lease Agreement)	\$ 6,000.00			
260	EFT16432	21/05/2021	AMPAC Debt Recovery Pty Ltd			\$ 5,006.10		
261	INV 75226	30/04/2021	AMPAC Debt Recovery Pty Ltd	RATES - DEBT COLLECTION EXPENSES - Debt Recovery April 2021	\$ 5,006.10			
262	EFT16433	21/05/2021	Easifleet			\$ 2,773.37		
263	INV 120521	13/05/2021	Easifleet	NOVATED LEASE - Employee Expenses PPE 12/05/2021	\$ 2,773.37			
264	EFT16434	21/05/2021	Conway Highbury Pty Ltd			\$ 1,636.25		
265	INV 552	30/04/2021	Conway Highbury Pty Ltd	OTHGOV - OTHER CONSULTANCY STATUTORY - Consultancy for provision of Governance Services January - March 2021	\$ 1,636.25			
266	EFT16435	21/05/2021	BKS Electrical Pty Ltd			\$ 1,699.50	L	
267	INV 2582	21/04/2021	BKS Electrical Pty Ltd	REC - GRANTS - OTHER RECREATION - Electrical Work for BBQ at Community BMX Track	\$ 1,699.50			
268	EFT16436	21/05/2021	Narrogin Guardian Pharmacy			\$ 69.30	L	
269	INV 993964	14/04/2021	Narrogin Guardian Pharmacy	ADMIN - OCCUPATION HEALTH & SAFETY - Re-Stock First Aid Kit	\$ 69.30			
270	EFT16437	21/05/2021	Narrogin Bowling Club			\$ 408.00	L	
271	INV 124	17/02/2021	Narrogin Bowling Club	ADMIN - TRAINING & DEVELOPMENT - Corporate Bowls - Nominations & Greens Fees for 3 Teams	\$ 408.00			
272	EFT16438	21/05/2021	Komatsu Australia Pty Ltd			\$ 281.12		
273	INV 002306703	06/05/2021	Komatsu Australia Pty Ltd	1EYN610 KOMATSU WA380-6 WHEEL LOADER - Service Filters	\$ 281.12			
274	EFT16439	21/05/2021	Narrogin Tyre Service			\$ 285.00	L	
275	INV 12956	07/04/2021	Narrogin Tyre Service	NGN3146 1985 TORO MOWER TRAILER - Puncture Repair Kit	\$ 45.00			
276	INV 13521	14/04/2021	Narrogin Tyre Service	1TOQ338 2013 TIPPER TRAILER - Tyres x2	\$ 240.00			

	Chq/EFT/DD	Date	Name	Description	Invoice Amount	Payment Total	Type	Funding
277	EFT16440	21/05/2021	Narrogin Auto Centre			\$ 699.52	L	
278	INV 298202	18/02/2021	Narrogin Auto Centre	NO0 2017 MITSUBISHI TRITON - Service Kit for 50,000Km Service	\$ 185.76			
279	INV 298887	11/03/2021	Narrogin Auto Centre	1NO 2018 NISSAN NAVARA - Filters x3 for 90,000Km Service	\$ 250.87			
280	INV 299189	22/03/2021	Narrogin Auto Centre	NO592 MITSUBISHI TRITON - Service Kit	\$ 262.89			
281	EFT16441	21/05/2021	Sherrin Rentals Pty Ltd			\$ 2,827.00		
282	INV 5155400	13/05/2021	Sherrin Rentals Pty Ltd	NARROGIN VALLEY ROAD - RENEWAL (RURAL) - 5 Day Water Cart Hire	\$ 2,827.00			
283	EFT16442	21/05/2021	Dale Stewart			\$ 1,033.89	L	
284	INV 270421	27/04/2021	Dale Stewart	ADMIN - OTHER EMPLOYEE EXPENSES - Internet Usage (08/07/2020-08/05/2021)	\$ 714.89			
285	INV 050521	05/05/2021	Dale Stewart	ADMIN - OTHER EMPLOYEE EXPENSES - Reimbursement - Firewood for 88 Forrest St Narrogin	\$ 319.00			
286	EFT16443	21/05/2021	The White Family Trust T/a Narrogin Valley Stockfeed			\$ 79.00	L	
287	INV NVS60520	13/05/2021	The White Family Trust T/a Narrogin Valley Stockfeed	ANIMAL POUND OPERATIO SN - Alert Plus 20Kg Dog Food x2	\$ 79.00			
288	EFT16444	21/05/2021	Kulbardi Hill Consulting			\$ 2,046.00		
289	INV 241	17/04/2021	Kulbardi Hill Consulting	ADMIN - PRINTING & STATIONERY - Stories of Us Narrogin Heritage Walk Trail Brochure (5000 Print Copies)	\$ 2,046.00			
290	EFT16445	21/05/2021	Johns Building Supplies			\$ 915.53		PF
291	INV 969209	10/05/2021	Johns Building Supplies	RAILWAY STATION RESTORATION COVID RECOVERY PROJECT - 90x45 4800mm Treated Pin x35	\$ 915.53			
292	EFT16446	21/05/2021	Danka Scholtz Von Lorenz			\$ 1,155.00		
293	INV 80	03/05/2021	Danka Scholtz Von Lorenz	OTHCUL - ARTWORK COLLECTION - 1st Instalment Charnock Woman - Reconstruction	\$ 1,155.00			
294	EFT16447	21/05/2021	Down to Earth Training & Assessing			\$ 2,814.10		
295	INV 00033351	10/05/2021	Down to Earth Training & Assessing	WORKS - TRAINING & DEVELOPMENT - 2 Day Training - Grader, Excavator, Backhoe, Loader, Skidsteer & Rollers	\$ 2,814.10			
296	EFT16448	21/05/2021	RCPA (WA) Pty Ltd			\$ 6,136.68		
297	INV 309278	06/05/2021	RCPA (WA) Pty Ltd	PARKS ROAD RENEWAL (CAPITAL) - 375 Headwalls x12	\$ 3,696.00			
298	INV 309291	07/05/2021	RCPA (WA) Pty Ltd	SMITH STREET - RENEWAL (LOCAL) (R2R) - Class Two Concrete Pipers x24	\$ 2,440.68			F

	Chq/EFT/DD	Date	Name	Description	Invoice Amount	Payment Total	Type	Funding
299	EFT16449	21/05/2021	Earl Street Physiotherapy			\$ 75.00	L	F
300	INV 0020242	10/05/2021	Earl Street Physiotherapy	CHCP - CLIENT PURCHASES - Physiotherapy Appointment (Client: L Burges)	\$ 75.00			
301	EFT16450	21/05/2021	The Rustic Vault			\$ 841.57	L	
302	INV 0172	12/02/2021	The Rustic Vault	CARAVAN PARK GENERAL MAINTENANCE/OPERATIONS - White Ecology Dinner Set & Villa Plus Pillows x2	\$ 121.99			
303	INV 0181	31/03/2021	The Rustic Vault	CARAVAN PARK GENERAL MAINTENANCE/OPERATIONS - Hand Towels x6, Bath Mats x6, Bath Towels x24 & Mugs x6	\$ 719.58			
304	EFT16451	21/05/2021	Manisha Barthakur			\$ 99.22	L	
305	INV 130521	13/05/2021	Manisha Barthakur	ADMIN - TRAINING & DEVELOPMENT - Reimbursement - Parking for Training (19/03/2021) & Uber To & From Training (10/05/2021)	\$ 99.22			
306	PAYROLL 24	24/05/2021	PAYROLL	Payroll 24 - 24/05/2021	\$ 156,267.19			
307	EFT16452	26/05/2021	Department Of Human Services			\$ 244.70		
308	INV DEDUCTION	24/05/2021	Department Of Human Services	Payroll deductions	\$ 244.70			
309	EFT16453	26/05/2021	Local Government Racing & Cemeteries Employees Union (LGREU)			\$ 20.50		
310	INV DEDUCTION	24/05/2021	Local Government Racing & Cemeteries Employees Union (LGREU)	Payroll deductions	\$ 20.50			
311	EFT16454	26/05/2021	Australian Services Union Western Australian Branc			\$ 25.90		
312	INV DEDUCTION	24/05/2021	Australian Services Union Western Australian Branc	Payroll deductions	\$ 25.90			
313	EFT16455	27/05/2021	Narrogin Hire & Reticulation			\$ 1,003.60	L	PF
314	INV 00030019	06/04/2021	Narrogin Hire & Reticulation	CARAVAN PARK GENERAL MAINTENANCE/OPERATIONS - Reticulation Materials	\$ 161.60			
315	INV 00030168	28/04/2021	Narrogin Hire & Reticulation	OTHCUL - ANZAC DAY - Chair Hire x400	\$ 800.00			
316	INV 0030272	12/05/2021	Narrogin Hire & Reticulation	RAILWAY STATION RESTORATION COVID RECOVERY PROJECT - Hire of Scaffold to Remove Wire	\$ 42.00			
317	EFT16456	27/05/2021	Narrogin Packaging			\$ 624.22	L	
318	INV 00069639	24/03/2021	Narrogin Packaging	CARAVAN PARK GENERAL MAINTENANCE/OPERATIONS - Cleaning Supplies	\$ 63.50			
319	INV 00070285	15/05/2021	Narrogin Packaging	VARIOUS PUBLIC TOILETS - Cleaning Supplies	\$ 523.32			
320	INV 00070290	17/05/2021	Narrogin Packaging	CARAVAN PARK GENERAL MAINTENANCE/OPERATIONS - Cleaning Supplies	\$ 37.40			

	Chq/EFT/DD	Date	Name	Description	Invoice Amount	Payment Total	Type	Funding
321	EFT16457	27/05/2021	Great Southern Fuels			\$ 18,608.37	L	
322	INV D2066028	13/05/2021	Great Southern Fuels	POC - FUELS AND OILS - 15,000L Diesel	\$ 18,608.37			
323	EFT16458	27/05/2021	Water Corporation			\$ 739.47		
324	INV 9C5S3	26/05/2021	Water Corporation	VARIOUS BUILDINGS - Water Service Charges (01/05/2021-30/06/2021)	\$ 739.47			
325	EFT16459	27/05/2021	Kleenheat Gas			\$ 11,510.46		
326	INV 2723745	13/05/2021	Kleenheat Gas	NRLC - UTILITY - ELECTRICITY - Electricity Usage (01/04/2021-30/04/2021)	\$ 9,396.51			
327	INV 2723717	13/05/2021	Kleenheat Gas	CARAVAN PARK GENERAL MAINTENANCE/OPERATIONS - Electricity Usage (01/04/2021-30/04/2021)	\$ 1,448.44			
328	INV 2723727	13/05/2021	Kleenheat Gas	ADMIN OFFICE BUILDING OPERATIONS - Electricity Usage (01/04/2021-30/04/2021)	\$ 665.51			
329	EFT16460	27/05/2021	Knightline Computers			\$ 279.00	L	
330	INV 00073012	28/04/2021	Knightline Computers	ADMIN - INFORMATION SYSTEMS - Universal Toshiba Dynadock (EMTRS) & Delivery	\$ 279.00			
331	EFT16461	27/05/2021	Nutrien Ag Solutions			\$ 117.70	L	
332	INV 904562878	22/04/2021	Nutrien Ag Solutions	HEALTH - ALLOWANCES - PPE Work boots (M Zhuo)	\$ 117.70			
333	EFT16462	27/05/2021	Makit Narrogin Hardware			\$ 176.30	L	F
334	INV 113321	22/12/2020	Makit Narrogin Hardware	CHSP HOME MAINTENANCE OTHER EXPENSES - Round Up	\$ 31.60			
335	INV 113520	19/03/2021	Makit Narrogin Hardware	VARIOUS CHSP SERVICES - 1L Round Up & Surge Protector 5 Plug Powerboard	\$ 74.20			
336	INV 113617	28/04/2021	Makit Narrogin Hardware	CHCP - CLIENT PURCHASES - Digital Medication Safe x1 (Client: C Thompsett)	\$ 70.50			
337	EFT16463	27/05/2021	Susan Farrell			\$ 50.00	L	
338	INV 036	26/05/2021	Susan Farrell	MEMBERS - CIVIC FUNCTIONS, REFRESHMENTS & RECEPTIONS - Various Ranges of Laundry	\$ 50.00			
339	EFT16464	27/05/2021	Westrac Pty Ltd			\$ 8.95		
340	INV PI 5548589	09/03/2021	Westrac Pty Ltd	1EVP731 2015 CAT SKID STEER LOADER - Stud & Nut	\$ 8.95			
341	EFT16465	27/05/2021	Narrogin Newsagency			\$ 1,021.56	L	
342	INV 1537 - 281783	10/05/2021	Narrogin Newsagency	VARIOUS DEPARTMENTS - Stationery Order April 2021	\$ 1,021.56			

	Chq/EFT/DD	Date	Name	Description	Invoice Amount	Payment Total	Type	Funding
343	EFT16466	27/05/2021	Narrogin Electrical Services			\$ 93.50	L	
344	INV 2323	18/05/2021	Narrogin Electrical Services	ADMIN OFFICE BUILDING MAINTENANCE - Electrical call out for Reception Sliding Doors	\$ 93.50			
345	EFT16467	27/05/2021	It Vision			\$ 1,749.00		
346	INV 35146	20/05/2021	It Vision	ADMIN - TRAINING & DEVELOPMENT - End of Year Financials - Manisha Barthakur & Cassey Klomp	\$ 1,309.00			
347	INV 35148	20/05/2021	It Vision	ADMIN - TRAINING & DEVELOPMENT - End of Year Payroll - Casey McRae	\$ 440.00			
348	EFT16468	27/05/2021	Narrogin Betta Home Living			\$ 3,592.00	L	F
349	INV 25710022874	19/04/2021	Narrogin Betta Home Living	CHCP - CLIENT PURCHASES - LG Cord New Master Vacuum Cleaner (Jessie House)	\$ 898.00			
350	INV 25710023210	30/04/2021	Narrogin Betta Home Living	CHCP - CLIENT PURCHASES - LG Cord New Master Vacuum Cleaner x3	\$ 2,694.00			
351	EFT16469	27/05/2021	Allans Bobcat And Truck Hire			\$ 484.00	L	
352	INV 00001468	10/05/2021	Allans Bobcat And Truck Hire	CEMETERY GRAVE DIGGING - Grave Dig x1 (Draper)	\$ 242.00			
353	INV 00001468	10/05/2021	Allans Bobcat And Truck Hire	CEMETERY GRAVE DIGGING - Grave Dig x1 (Moore)	\$ 242.00			
354	EFT16470	27/05/2021	Narrogin Glass & Quick Fit Windscreens			\$ 77.00	L	
355	INV 00055519	31/03/2021	Narrogin Glass & Quick Fit Windscreens	NGN219 2019 NISSAN X-TRAIL - Windscreen Chip Repair	\$ 77.00			
356	EFT16471	27/05/2021	RJ Smith Engineering			\$ 177.00	L	PF
357	INV 00013355	20/05/2021	RJ Smith Engineering	RAILWAY STATION RECOVERY COVID RECOVERY PROJECT - Stirrups	\$ 50.00			
358	INV 0013356	20/05/2021	RJ Smith Engineering	PWO - WORKS - PROTECTIVE CLOTHING - Box of Nitrile Gloves x3	\$ 127.00			
359	EFT16472	27/05/2021	Octave Holdings Pty Ltd T/A Narrogin Toyota			\$ 416.48	L	
360	INV JC24029282	10/05/2021	Octave Holdings Pty Ltd T/A Narrogin Toyota	990NGN 2015 MITSUBISHI FUSO ROSA - Replace Fan Belts & Inspect Braking System	\$ 416.48			
361	EFT16473	27/05/2021	Bucher Municipal Pty Ltd - McDonald Johnston			\$ 412.54		
362	INV 1001269	12/05/2021	Bucher Municipal Pty Ltd - McDonald Johnston	1EUF156 HINO ROAD SWEEPER 2004 - Parts to Repair Sweeper	\$ 412.54			
363	EFT16474	27/05/2021	Air Response			\$ 514.95	L	
364	INV 152784A	01/11/2020	Air Response	CAFE 45 FEDERAL ST BUILDING MAINTENANCE - Fit Door Seal, Adjust Door Hings & Refit Door Latch to Cool Room (Additional Work required to make Cafe operational)	\$ 447.44			
365	INV 153357A	23/03/2021	Air Response	CARAVAN PARK GENERAL MAINTENANCE/OPERATIONS - Inspection of Air-Con Unit	\$ 67.51			

	Chq/EFT/DD	Date	Name	Description	Invoice Amount	Payment Total	Type	Funding
366	EFT16475	27/05/2021	Goodyear Dunlop Tyres Pty Ltd (Beaurepaires)			\$ 60.00	L	
367	INV 6412020094	19/05/2021	Goodyear Dunlop Tyres Pty Ltd (Beaurepaires)	NO05 2018 NISSAN NAVARA - 2m Flat Rubber Matting	\$ 60.00			
368	EFT16476	27/05/2021	Toll Transport Pty Ltd			\$ 228.04		
369	INV 0490-T740710	18/04/2021	Toll Transport Pty Ltd	VARIOUS DEPARTMENTS - Freight Charges (13/04/2021-16/04/2021)	\$ 56.93			
370	INV 0491-T7404710	25/04/2021	Toll Transport Pty Ltd	LYDEKER DEPOT BUILDING OPERATIONS - Freight Charges (23/04/2021)	\$ 28.11			
371	INV 0492-T740710	09/05/2021	Toll Transport Pty Ltd	VARIOUS DEPARTMENTS - Freight Charges (07/05/2021)	\$ 143.00			
372	EFT16477	27/05/2021	Bob Waddell & Associates Pty Ltd			\$ 132.00		
373	INV 2277	10/05/2021	Bob Waddell & Associates Pty Ltd	RATES - CONSULTANTS - Assistance with Rates enquiries & task (09/05/2021)	\$ 132.00			
374	EFT16478	27/05/2021	John Parry Medical Centre			\$ 378.00	L	F
375	INV 401074	20/04/2021	John Parry Medical Centre	CHSP - RECRUITMENT - Pre-Employment Medical for Lesley Booth	\$ 126.00			
376	INV 402462	05/05/2021	John Parry Medical Centre	CHSP - RECRUITMENT - Pre-Employment Medical for Karen Streeter	\$ 126.00			
377	INV 402878	10/05/2021	John Parry Medical Centre	CHSP - RECRUITMENT - Pre-Employment Medical for Hannah Pitchers	\$ 126.00			
378	EFT16479	27/05/2021	Melchiorre Plumbing & Gas			\$ 2,486.00	L	PF
379	INV 7637	06/05/2021	Melchiorre Plumbing & Gas	RAILWAY STATION RESTORATION COVID RECOVERY PROJECT - 113m Stormwater Drainage & Extra Jackhammer Hire	\$ 2,486.00			
380	EFT16480	27/05/2021	YMCA WA			\$ 2,595.00	L	
381	INV SI-A010237	16/03/2021	YMCA WA	MEMBERS - CIVIC FUNCTIONS, REFRESHMENTS & RECEPTIONS - Venue Hire for Council Zone Meeting - John Higgins Centre 26/02/2021	\$ 605.00			
382	INV SI-A010309	27/04/2021	YMCA WA	WELFARE - YOUTH SERVICES - Youth Week 2021 - Reimbursemnt of Activities Costs	\$ 1,990.00			
383	EFT16481	27/05/2021	Parks And Leisure Australia			\$ 825.00		
384	INV W17117	17/05/2021	Parks And Leisure Australia	COMMUNITY - SUBSCRIPTIONS AND MEMBERSHIPS - Corporate Subscription 01/07/2021-30/06/2022	\$ 825.00			
385	EFT16482	27/05/2021	Landmark Products Pty Ltd			\$ 4,763.00		
386	INV 126831	30/04/2021	Landmark Products Pty Ltd	STREET FURNITURE - Supply of Steel Slatted Council 2.0m Seat with Bolt-down Legs x2 & Delivery	\$ 4,763.00			
387	EFT16483	27/05/2021	Keen's Truck Driver Training			\$ 1,645.00		
388	INV 00201319	18/05/2021	Keen's Truck Driver Training	WORKS - TRAINING & DEVELOPMENT - Day HC Training & Assessment (K. Head)	\$ 1,645.00			

	Chq/EFT/DD	Date	Name	Description	Invoice Amount	Payment Total	Type	Funding
389	EFT16484	27/05/2021	Win Television WA Pty Ltd T/A WIN Television Network			\$ 1,207.80		
390	INV 1066066-1	30/04/2021	Win Television WA Pty Ltd T/A WIN Television Network	MEMBERS - ADVERTISING & PROMOTIONS - Shire Promotion on WIN WA Networks April 2021	\$ 1,081.30			
391	INV 1066079-1	30/04/2021	Win Television WA Pty Ltd T/A WIN Television Network	MEMBERS - ADVERTISING & PROMOTIONS - Shire Promotion on WIN PEACH WA Networks April 2021	\$ 60.50			
392	INV 1066090-1	30/04/2021	Win Television WA Pty Ltd T/A WIN Television Network	MEMBERS - ADVERTISING & PROMOTIONS - Shire Promotion on WIN BOLD WA Networks April 2021	\$ 66.00			
393	EFT16485	27/05/2021	Farmworks Narrogin Pty Ltd			\$ 151.00	L	F
394	INV 85419	14/04/2021	Farmworks Narrogin Pty Ltd	VARIOUS CHSP SERVICES - 20L Round Up & 20Kg Poultry Mix	\$ 151.00			
395	EFT16486	27/05/2021	General Tech Narrogin			\$ 355.00	L	
396	INV 00009526	18/05/2021	General Tech Narrogin	MEMBERS - EXPENSED MINOR ASSET PURCHASES - 3M Long iPhone Lightening Cable	\$ 35.00			
397	INV 00009527	18/05/2021	General Tech Narrogin	ANIMAL - EXPENSED MINOR ASSET PURCHASES - Targus Docking Station x2 (Rangers)	\$ 150.00			
398	INV 00009531	18/05/2021	General Tech Narrogin	PWO - GENERAL OFFICE EXPENSES - Mobile Phone Charger	\$ 20.00			
399	INV 00009525	18/05/2021	General Tech Narrogin	ADMIN - INFORMATION SYSTEMS - Targus Universal Docking Station (MCS)	\$ 75.00			
400	INV 00009528	18/05/2021	General Tech Narrogin	ADMIN - INFORMATION SYSTEMS - Targus Universal Docking Station (EMTRS)	\$ 75.00			
401	EFT16487	27/05/2021	Johns Building Supplies			\$ 2,171.95		PF
402	INV 970976	18/05/2021	Johns Building Supplies	RAILWAY STATION RESTORATION COVIDE RECOVERY PROJECT - 25 Sheets of 19mm Flooring Panel (Termite Treated)	\$ 2,171.95			
403	EFT16488	27/05/2021	Narrogin Fresh			\$ 2,537.13	L	PF
404	INV DEC (3) 2020	21/12/2020	Narrogin Fresh	VARIOUS DEPARTMENTS - Narrogin Fresh Account December (3) 2020	\$ 717.88			
405	INV MARCH (4)	26/03/2021	Narrogin Fresh	VARIOUS DEPARTMENTS - Narrogin Fresh Account March (4) 2021	\$ 376.91			
406	INV APRIL (2) 2021	30/04/2021	Narrogin Fresh	VARIOUS DEPARTMENTS - Narrogin Fresh Account April (2) 2021	\$ 740.65			
407	INV MAY 2021	17/05/2021	Narrogin Fresh	VARIOUS DEPARTMENTS - Narrogin Fresh Account May 2021	\$ 701.69			
408	EFT16489	27/05/2021	BMR Mechanical Pty Ltd			\$ 5,337.79	L	
409	INV INV-0412	16/04/2021	BMR Mechanical Pty Ltd	NO4929 2015 HAMM 3520HT STEEL VIBE ROLLER - Repairs to Vibe Motor & Drum	\$ 5,337.79			
410	EFT16490	27/05/2021	Prime Media Group			\$ 368.50		
411	INV 384258	30/04/2021	Prime Media Group	TOUR - PUBLIC RELATIONS & AREA PROMOTION - Television Campaign Broadcasting April 2021	\$ 368.50			

	Chq/EFT/DD	Date	Name	Description	Invoice Amount	Payment Total	Type	Funding	
412	EFT16491	27/05/2021	Wheatbelt Hydrology			\$ 15,112.53	L		
413	INV NARSWMP-03	14/05/2021	Wheatbelt Hydrology	VARIOUS STORM WATER REPORTS - Hydrology Consultancy (RFQ 19/20-07)	\$ 15,112.53				
414	EFT16492	27/05/2021	Kunal Sarma			\$ 325.00	L		
415	INV 180521	18/05/2021	Kunal Sarma	PWO - GENERAL OFFICE EXPENSES - Reimbursement - LCD & Battery Replacement (for Manager of Operations Old Phone)	\$ 325.00				
416	EFT16493	27/05/2021	Narrogin & Districts Plumbing Service			\$ 2,829.20	L		
417	INV INV-0394	16/05/2021	Narrogin & Districts Plumbing Service	FIRE - EXPENSED MINOR ASSET PURCHASES - Ockley Brigade - Plumbing in of Water Tank	\$ 2,829.20				
418	EFT16494	27/05/2021	WIN Network Pty Ltd			\$ 88.00			
419	INV 1066100-1	30/04/2021	WIN Network Pty Ltd	MEMBERS - ADVERTISING & PROMOTIONS - Shire Promotion on SKY News Networks April 2021	\$ 88.00				
420	EFT16495	27/05/2021	Jennifer Fowler			\$ 1,261.00	L	F	
421	INV 206	15/05/2021	Jennifer Fowler	CHCP - CLIENT PURCHASES - Appointment with Occupational Therapist - Client: M. Brewster	\$ 1,261.00				
422	EFT16496	27/05/2021	Divine's Coffee Cups			\$ 495.00	L		
423	INV INV-005	17/05/2021	Divine's Coffee Cups	MEMBERS - CIVIC FUNCTIONS, REFRESHMENTS & RECEPTIONS - Catering for Council Meeting 12/05/2021	\$ 495.00				
424	EFT16497	27/05/2021	Gary Anthony Betteley			\$ 2,474.08	L		
425	INV A340242	17/05/2021	Gary Anthony Betteley	Rates refund for assessment A340242 Lot 10567 Blight Road HIGHBURY 6313	\$ 2,474.08				
					EFT Total \$	1,136,079.83			

Chq/EFT/DD	Date	Name	Description	Invoice Amount	Payment Total	Type	Funding
Direct Debits							
426	DD6507.1	07/05/2021	Australian Taxation Office		\$ 111,424.00		
427	INV BAS MARCH	31/03/2021	Australian Taxation Office	BAS - March 2021	\$ 111,424.00		
428	DD6510.1	03/05/2021	Keenan & Tania Wenning		\$ 1,386.67	L	
429	INV EMDRS MAY 2021	03/05/2021	Keenan & Tania Wenning	EMDRS STAFF HOUSING RENTAL PROPERTY EXPENSES - Rent May 2021	\$ 1,386.67		
430	DD6511.1	10/05/2021	Elgas		\$ 110.57		
431	INV 0360803862	30/04/2021	Elgas	CARAVAN PARK GENERAL MAINTENANCE/OPERATIONS - Gas Supplied 112.0L	\$ 110.57		
432	DD6529.1	10/05/2021	Aware Super		\$ 16,137.36		
433	INV SUPER	10/05/2021	Aware Super	Superannuation contributions	\$ 13,484.65		
434	INV DEDUCTION	10/05/2021	Aware Super	Payroll deductions	\$ 260.00		
435	INV DEDUCTION	10/05/2021	Aware Super	Payroll deductions	\$ 150.00		
436	INV DEDUCTION	10/05/2021	Aware Super	Payroll deductions	\$ 184.43		
437	INV DEDUCTION	10/05/2021	Aware Super	Payroll deductions	\$ 136.79		
438	INV DEDUCTION	10/05/2021	Aware Super	Payroll deductions	\$ 1,657.01		
439	INV DEDUCTION	10/05/2021	Aware Super	Payroll deductions	\$ 122.17		
440	INV DEDUCTION	10/05/2021	Aware Super	Payroll deductions	\$ 142.31		
441	DD6529.2	10/05/2021	Mtaa Super		\$ 191.76		
442	INV SUPER	10/05/2021	Mtaa Super	Superannuation contributions	\$ 191.76		
443	DD6529.3	10/05/2021	Bt Super For Life		\$ 1,042.00		
444	INV SUPER	10/05/2021	Bt Super For Life	Superannuation contributions	\$ 873.31		
445	INV DEDUCTION	10/05/2021	Bt Super For Life	Payroll deductions	\$ 67.59		
446	INV DEDUCTION	10/05/2021	Bt Super For Life	Payroll deductions	\$ 101.10		
447	DD6529.4	10/05/2021	Prime Super		\$ 545.79		
448	INV SUPER	10/05/2021	Prime Super	Superannuation contributions	\$ 545.79		

Chq/EFT/DD	Date	Name	Description	Invoice Amount	Payment Total	Type	Funding
449	DD6529.5	10/05/2021	Cbus Super Fund		\$ 188.80		
450	INV SUPER	10/05/2021	Cbus Super Fund	Superannuation contributions	\$ 188.80		
451	DD6529.6	10/05/2021	Lgia Super		\$ 980.30		
452	INV SUPER	10/05/2021	Lgia Super	Superannuation contributions	\$ 497.78		
453	INV DEDUCTION	10/05/2021	Lgia Super	Payroll deductions	\$ 300.00		
454	INV DEDUCTION	10/05/2021	Lgia Super	Payroll deductions	\$ 182.52		
455	DD6529.7	10/05/2021	Rest Superannuation		\$ 423.28		
456	INV SUPER	10/05/2021	Rest Superannuation	Superannuation contributions	\$ 323.28		
457	INV DEDUCTION	10/05/2021	Rest Superannuation	Payroll deductions	\$ 100.00		
458	DD6529.8	10/05/2021	Essential Super		\$ 190.35		
459	INV SUPER	10/05/2021	Essential Super	Superannuation contributions	\$ 190.35		
460	DD6529.9	10/05/2021	Oasis Superannuation Service		\$ 204.18		
461	INV SUPER	10/05/2021	Oasis Superannuation Service	Superannuation contributions	\$ 204.18		
462	DD6533.1	17/05/2021	Elgas		\$ 4,479.73		
463	INV 0360884060	05/05/2021	Elgas	NRLC - UTILITY - GAS - Gas Supplied 4,641.0L	\$ 4,479.73		
464	DD6540.1	17/05/2021	Sandwai Pty Ltd		\$ 1,071.40		F
465	INV MAY2021	17/05/2021	Sandwai Pty Ltd	CHSP - INFORMATION SYSTEMS GEN - Monthly Charges May 2021	\$ 1,071.40		
466	DD6541.1	17/05/2021	Telstra		\$ 2,018.32		PF
467	INV K054035830-5	12/05/2021	Telstra	VARIOUS DEPARTMENTS - Mobile Phone Charges May 2021	\$ 2,018.32		
468	DD6555.1	26/05/2021	Elgas		\$ 3,378.38		
469	INV 0360802914	13/05/2021	Elgas	NRLC - UTILITY - GAS - Gas Supplied 3,500.0 L	\$ 3,378.38		

Chq/EFT/DD	Date	Name	Description	Invoice Amount	Payment Total	Type	Funding
470	DD6562.1	24/05/2021	Aware Super				
471	INV SUPER	24/05/2021	Aware Super	Superannuation contributions	\$ 13,272.46		
472	INV DEDUCTION	24/05/2021	Aware Super	Payroll deductions	\$ 260.00		
473	INV DEDUCTION	24/05/2021	Aware Super	Payroll deductions	\$ 150.00		
474	INV DEDUCTION	24/05/2021	Aware Super	Payroll deductions	\$ 180.94		
475	INV DEDUCTION	24/05/2021	Aware Super	Payroll deductions	\$ 131.56		
476	INV DEDUCTION	24/05/2021	Aware Super	Payroll deductions	\$ 1,643.32		
477	INV DEDUCTION	24/05/2021	Aware Super	Payroll deductions	\$ 122.17		
478	INV DEDUCTION	24/05/2021	Aware Super	Payroll deductions	\$ 142.31		
479	DD6562.2	24/05/2021	Media Super			\$ 181.72	
480	INV SUPER	24/05/2021	Media Super	Superannuation contributions	\$ 181.72		
481	DD6562.3	24/05/2021	Rest Superannuation			\$ 647.30	
482	INV SUPER	24/05/2021	Rest Superannuation	Superannuation contributions	\$ 547.30		
483	INV DEDUCTION	24/05/2021	Rest Superannuation	Payroll deductions	\$ 100.00		
484	DD6562.4	24/05/2021	Mtaa Super			\$ 191.76	
485	INV SUPER	24/05/2021	Mtaa Super	Superannuation contributions	\$ 191.76		
486	DD6562.5	24/05/2021	Bt Super For Life			\$ 1,030.34	
487	INV SUPER	24/05/2021	Bt Super For Life	Superannuation contributions	\$ 861.65		
488	INV DEDUCTION	24/05/2021	Bt Super For Life	Payroll deductions	\$ 67.59		
489	INV DEDUCTION	24/05/2021	Bt Super For Life	Payroll deductions	\$ 101.10		
490	DD6562.6	24/05/2021	Prime Super			\$ 566.40	
491	INV SUPER	24/05/2021	Prime Super	Superannuation contributions	\$ 566.40		
492	DD6562.7	24/05/2021	Cbus Super Fund			\$ 196.19	
493	INV SUPER	24/05/2021	Cbus Super Fund	Superannuation contributions	\$ 196.19		

	Chq/EFT/DD	Date	Name	Description	Invoice Amount	Payment Total	Type	Funding
494	DD6562.8	24/05/2021	Lgia Super			\$ 980.30		
495	INV SUPER	24/05/2021	Lgia Super	Superannuation contributions	\$ 497.78			
496	INV DEDUCTION	24/05/2021	Lgia Super	Payroll deductions	\$ 300.00			
497	INV DEDUCTION	24/05/2021	Lgia Super	Payroll deductions	\$ 182.52			
498	DD6562.9	24/05/2021	Essential Super			\$ 190.35		
499	INV SUPER	24/05/2021	Essential Super	Superannuation contributions	\$ 190.35			
500	DD6565.1	27/05/2021	Western Power			\$ 1,320.00		
501	INV CORP0547010	29/04/2021	Western Power	CEMETERY MAINTENANCE/OPERATIONS - Design Fee - Supply of Electricity to Lot 1630, 152 Williams Road, Narrogin	\$ 1,320.00			
502	DD6573.1	24/05/2021	Easifleet			\$ 924.70		
503	INV 145148	07/05/2021	Easifleet	FIRE - MOTOR VECHICLE EXPENSES - Lease of Holden Colorado (NGN12398) for Bushfire Risk Planning Co-Ordinator - May 2021	\$ 924.70			
504	DD6577.1	31/05/2021	Aaron Joseph Cook			\$ 2,245.54		
505	INV CEO MAY 2021 RENT	31/05/2021	Aaron Joseph Cook	CEO STAFF HOUSING RENTAL PROPERTY EXPENSES - Rent May 2021	\$ 2,245.54			
506	DD6592.1	28/05/2021	WA Treasury Corporation			\$ 19,424.67		
507	INV 129	28/05/2021	WA Treasury Corporation	Loan No. 129 Interest payment - Accommodation Units NCP	\$ 19,424.67			
508	DD6593.1	18/05/2021	WA Treasury Corporation			\$ 5,195.65		
509	INV 121B	18/05/2021	WA Treasury Corporation	Loan No. 121B Interest payment - Repayment of NLC Loan	\$ 5,195.65			
510	DD6594.1	31/05/2021	WA Treasury Corporation			\$ 42,904.46		
511	INV 126	31/05/2021	WA Treasury Corporation	Loan No. 126 Interest payment - Town Hall Renovations	\$ 17,092.62			
512	INV 128	31/05/2021	WA Treasury Corporation	Loan No. 128 Interest payment - Administration Building Extention	\$ 25,811.84			
513	DD6529.10	10/05/2021	Mercer Super Trust			\$ 74.89		
514	INV SUPER	10/05/2021	Mercer Super Trust	Superannuation contributions	\$ 74.89			
515	DD6529.11	10/05/2021	Colonial First State			\$ 341.63		
516	INV SUPER	10/05/2021	Colonial First State	Superannuation contributions	\$ 341.63			
517	DD6529.12	10/05/2021	Qsuper			\$ 372.81		
518	INV SUPER	10/05/2021	Qsuper	Superannuation contributions	\$ 372.81			

	Chq/EFT/DD	Date	Name	Description	Invoice Amount	Payment Total	Type	Funding
519	DD6529.13	10/05/2021	loof			\$ 244.67		
520	INV SUPER	10/05/2021	loof	Superannuation contributions	\$ 244.67			
521	DD6529.14	10/05/2021	Host Plus			\$ 348.98		
522	INV SUPER	10/05/2021	Host Plus	Superannuation contributions	\$ 292.18			
523	INV DEDUCTION	10/05/2021	Host Plus	Payroll deductions	\$ 56.80			
524	DD6529.15	10/05/2021	Bt Superwrap			\$ 428.38		
525	INV DEDUCTION	10/05/2021	Bt Superwrap	Payroll deductions	\$ 114.93			
526	INV SUPER	10/05/2021	Bt Superwrap	Superannuation contributions	\$ 313.45			
527	DD6529.16	10/05/2021	Sunsuper			\$ 549.74		
528	INV DEDUCTION	10/05/2021	Sunsuper	Payroll deductions	\$ 140.96			
529	INV SUPER	10/05/2021	Sunsuper	Superannuation contributions	\$ 408.78			
530	DD6529.17	10/05/2021	Hesta Superannuation			\$ 1,008.35		
531	INV SUPER	10/05/2021	Hesta Superannuation	Superannuation contributions	\$ 838.35			
532	INV DEDUCTION	10/05/2021	Hesta Superannuation	Payroll deductions	\$ 170.00			
533	DD6529.18	10/05/2021	Australiansuper			\$ 1,713.95		
534	INV DEDUCTION	10/05/2021	Australiansuper	Payroll deductions	\$ 109.31			
535	INV DEDUCTION	10/05/2021	Australiansuper	Payroll deductions	\$ 637.00			
536	INV SUPER	10/05/2021	Australiansuper	Superannuation contributions	\$ 967.64			
537	DD6529.19	10/05/2021	Mlc Masterkey			\$ 249.35		
538	INV SUPER	10/05/2021	Mlc Masterkey	Superannuation contributions	\$ 249.35			
539	DD6529.20	10/05/2021	Bt Super For Life			\$ 115.47		
540	INV SUPER	10/05/2021	Bt Super For Life	Superannuation contributions	\$ 115.47			
541	DD6529.21	10/05/2021	Media Super			\$ 181.72		
542	INV SUPER	10/05/2021	Media Super	Superannuation contributions	\$ 181.72			

	Chq/EFT/DD	Date	Name	Description	Invoice Amount	Payment Total	Type	Funding
543	DD6562.10	24/05/2021	Oasis Superannuation Service			\$ 221.91		
544	INV SUPER	24/05/2021	Oasis Superannuation Service	Superannuation contributions	\$ 221.91			
545	DD6562.11	24/05/2021	Mercer Super Trust			\$ 134.35		
546	INV SUPER	24/05/2021	Mercer Super Trust	Superannuation contributions	\$ 134.35			
547	DD6562.12	24/05/2021	Qsuper			\$ 366.61		
548	INV SUPER	24/05/2021	Qsuper	Superannuation contributions	\$ 366.61			
549	DD6562.13	24/05/2021	Colonial First State			\$ 341.63		
550	INV SUPER	24/05/2021	Colonial First State	Superannuation contributions	\$ 341.63			
551	DD6562.14	24/05/2021	loof			\$ 229.31		
552	INV SUPER	24/05/2021	loof	Superannuation contributions	\$ 229.31			
553	DD6562.15	24/05/2021	Local Government Super			\$ 89.69		
554	INV SUPER	24/05/2021	Local Government Super	Superannuation contributions	\$ 89.69			
555	DD6562.16	24/05/2021	Bt Superwrap			\$ 464.78		
556	INV DEDUCTION	24/05/2021	Bt Superwrap	Payroll deductions	\$ 114.93			
557	INV SUPER	24/05/2021	Bt Superwrap	Superannuation contributions	\$ 349.85			
558	DD6562.17	24/05/2021	Host Plus			\$ 405.78		
559	INV SUPER	24/05/2021	Host Plus	Superannuation contributions	\$ 359.88			
560	INV DEDUCTION	24/05/2021	Host Plus	Payroll deductions	\$ 45.90			
561	DD6562.18	24/05/2021	Sunsuper			\$ 549.74		
562	INV DEDUCTION	24/05/2021	Sunsuper	Payroll deductions	\$ 140.96			
563	INV SUPER	24/05/2021	Sunsuper	Superannuation contributions	\$ 408.78			
564	DD6562.19	24/05/2021	Australiansuper			\$ 1,710.77		
565	INV DEDUCTION	24/05/2021	Australiansuper	Payroll deductions	\$ 109.31			
566	INV DEDUCTION	24/05/2021	Australiansuper	Payroll deductions	\$ 637.00			
567	INV SUPER	24/05/2021	Australiansuper	Superannuation contributions	\$ 964.46			

Chq/EFT/DD	Date	Name	Description	Invoice Amount	Payment Total	Type	Funding
568	DD6562.20	24/05/2021	Hesta Superannuation		\$ 1,016.31		
569	INV DEDUCTION	24/05/2021	Hesta Superannuation	Payroll deductions	\$ 170.00		
570	INV SUPER	24/05/2021	Hesta Superannuation	Superannuation contributions	\$ 846.31		
571	DD6562.21	24/05/2021	Mlc Masterkey		\$ 232.24		
572	INV SUPER	24/05/2021	Mlc Masterkey	Superannuation contributions	\$ 232.24		
573	DD6562.22	24/05/2021	Bt Super For Life		\$ 96.23		
574	INV SUPER	24/05/2021	Bt Super For Life	Superannuation contributions	96.23		
				Direct Debit Total	\$ 247,164.32		

Chq/EFT/DD	Date	Name	Description	Invoice Amount	Payment Total	Type	Funding
------------	------	------	-------------	----------------	---------------	------	---------

Credit Card Purchases

CEO & EMCCS		GENERAL Credit Card Purchases					
575	DD6578.1	24/05/2021	General Credit Card Purchases				\$5,499.46
576	INV FLAPR0121	06/04/2021	General Credit Card Purchases	CREDIT CARD April 2021 - Greeting Messages Homecare & Admin	\$151.80		
577	INV FLAPR1021	27/04/2021	General Credit Card Purchases	CREDIT CARD April 2021 - Phone Accessories (J Warburton)	\$165.89		
578	INV DSAPR0121	01/04/2021	General Credit Card Purchases	CREDIT CARD April - Adobe Spark Subscription	\$121.32		
579	INV DSAPR0221	01/04/2021	General Credit Card Purchases	CREDIT CARD April 2021 - Flights for Tidy Towns Awards (D Stewart & C Barton)	\$958.85		
580	INV DSAPR0321	17/04/2021	General Credit Card Purchases	Tickets for Tidy Town Awards (C Barton, L Ballard, D Stewart)	\$750.00		
581	INV DSAPR0421	01/04/2021	General Credit Card Purchases	CREDIT CARD April 2021 - Return Flights for Tidy Towns Awards (L Ballard)	\$497.02		
582	INV DSAPR0521	14/04/2021	General Credit Card Purchases	CREDIT CARD April 2021 - Monthly SMS Charges	\$17.60		
583	INV DSAPR0621	24/04/2021	General Credit Card Purchases	CREDIT CARD April 2021 - LG Conference 1x Meal (D Stewart)	\$24.20		
584	INV DSAPR0721	24/04/2021	General Credit Card Purchases	CREDIT CARD April 2021 - Fare from Airport to Hotel LG Conference (D Stewart)	\$10.00		
585	INV DSAPR0821	24/04/2021	General Credit Card Purchases	CREDIT CARD April 2021 - LG Conference 1x Meal (D Stewart)	\$93.20		
586	INV DSAPR0921	26/04/2021	General Credit Card Purchases	CREDIT CARD April 2021 - LG Conference 3x Nights Accommodation	\$ 704.00		
587	INV FLAPR0221	08/04/2021	General Credit Card Purchases	CREDIT CARD April 2021 - Renewal of Business Name	\$ 87.00		
588	INV DSAPR1021	24/04/2021	General Credit Card Purchases	CREDIT CARD April 2021 - Airport Parking (D Stewart)	\$ 101.03		
589	INV DSAPR1121	24/04/2021	General Credit Card Purchases	CREDIT Card April 2021 - Taxi from Airport (D Stewart)	\$ 25.56		
590	INV DSAPR1221	28/04/2021	General Credit Card Purchases	CREDIT CARD April 2021 - Accommodation (D Stewart)	\$ 153.15		
591	INV APRFEES	01/04/2021	General Credit Card Purchases	CREDIT CARD April 2021 - Transaction Fees	\$ 3.64		
592	INV FLAPR0321	13/04/2021	General Credit Card Purchases	CREDIT CARD April 2021 - Plate Change (Plates Lost)	\$ 45.90		
593	INV FLAPR0421	12/04/2021	General Credit Card Purchases	CREDIT CARD April 2021 - Seek Advertisement (CSO)	\$ 220.00		
594	INV FLAPR0521	14/04/2021	General Credit Card Purchases	CREDIT CARD April 2021 - Under Desk Keyboard Drawer	\$ 278.00		
595	INV FLAPR0621	14/04/2021	General Credit Card Purchases	CREDIT CARD April 2021 - Turbo Cad Delux	\$ 189.00		

Chq/EFT/DD	Date	Name	Description	Invoice Amount	Payment Total	Type	Funding
596	INV FLAPR0721	19/04/2021	General Credit Card Purchases	CREDIT CARD April 2021 - Purchase Made Incorrectly on Credit has since been Reimbursed	\$ 20.50		
597	INV FLAPR0821	16/04/2021	General Credit Card Purchases	CREDIT CARD April 2021 - Power Connection for Cemetry	\$ 497.92		
598	INV FLAPR0921	16/04/2021	General Credit Card Purchases	CREDIT CARD April 2021 - Vacuum & Accessories	\$ 383.88		
				Credit Card Total	\$5,499.46		
599							
600							
				Trust Total	\$0.00		

Chq/EFT/DD	Date	Name	Description	Invoice Amount	Payment Total	Type	Funding
------------	------	------	-------------	----------------	---------------	------	---------

ABBREVIATIONS		Cheque Total (Less TD)	\$0.00	0.00%
PF	Partially Funded	Term Deposits (TD)		
I		EFT Total*	\$829,214.68	59.71%
F	Funded	Payroll Total*	\$306,865.15	22.10%
L	Local Supplier	Direct Debit Total	\$247,164.32	17.80%
R	Recoverable	Credit Card Total	\$5,499.46	0.40%
		Trust Total	\$0.00	0.00%
			\$1,388,743.61	100.00%
		Total (Less Term Deposits)	\$1,388,743.61	
		Local Suppliers	\$277,150.01	19.96%
		Employees	\$306,865.15	22.10%
		Combined Total	\$584,015.16	42.05%

* Please note Payroll totals

10.3.2 MONTHLY FINANCIAL REPORTS – MAY 2021

File Reference	12.8.1
Disclosure of Interest	Neither the Author nor Authorising Officer have any Impartiality, Financial or Proximity Interest that requires disclosure.
Applicant	Shire of Narrogin
Previous Item Numbers	Nil
Date	8 June 2021
Author	Manisha Barthakur – Senior Finance Officer-Strategic
Authorising Officer	Alex Mulenga – Manager Corporate Services
Attachments	1. Monthly Financial Report for the period ended 31 May 2021.

Summary

In accordance with the Local Government Financial Management Regulations (1996), Regulation 34, the Shire is to prepare a monthly Statement of Financial Activity for notation by Council.

Background

Council is requested to review the May 2021 Monthly Financial Reports.

Consultation

Consultation has been undertaken with Executive Manager Corporate and Community Services.

Statutory Environment

Local Government (Financial Management) Regulations 1996, Regulation 34 applies.

Policy Implications

Nil

Financial Implications

All expenditure has been approved via adoption of the 2020/21 Annual Budget, or resulting from a Council Motion for a budget amendment.

Strategic Implications

Shire of Narrogin Strategic Community Plan 2017-2027	
Objective	4. Civic Leadership Objective (Continually enhance the Shire's organisational capacity to service the needs of a growing community)
Outcome:	4.1 An efficient and effective organisation

Comment/Conclusion

The May 2021 Monthly Financial Reports are presented for review.

Voting Requirements

Simple Majority.

OFFICERS' RECOMMENDATION

That, with respect to the Monthly Financial Reports for May 2021, Council note the Reports as presented.

MONTHLY FINANCIAL REPORT
(Containing the Statement of Financial Activity)
FOR THE PERIOD ENDED 31 MAY 2021



LOCAL GOVERNMENT ACT 1995
LOCAL GOVERNMENT (FINANCIAL MANAGEMENT) REGULATIONS 1996

TABLE OF CONTENTS

Monthly Summary Information	2 - 3
Statement of Financial Activity	4
Significant Accounting Policies	5
Adjusted Net Current Assets	6
Material Variances	7
Receivables	8
Capital Acquisitions	9-12
Cash Backed Reserves	13
Budget Amendments	14

**MONTHLY FINANCIAL REPORT
FOR THE PERIOD ENDED 31 MAY 2021**

**MONTHLY SUMMARY
INFORMATION**

PREPARATION TIMING AND REVIEW

Date prepared: All known transactions up to reporting period.
Prepared by: Manager Corporate Services
Reviewed by: Executive Manager Corporate & Community Services

BASIS OF PREPARATION

REPORT PURPOSE

This report is prepared to meet the requirements of *Local Government (Financial Management) Regulations 1996, Regulation 34*. Note: The statements and accompanying notes are prepared based on all transactions recorded at the time of preparation and may vary due to transactions being processed for the reporting period after the date of preparation.

BASIS OF ACCOUNTING

This statement comprises a special purpose financial report which has been prepared in accordance with Australian Accounting Standards (as they apply to local governments and not-for-profit entities and to the extent they are not in-consistent with the *Local Government Act 1995* and accompanying regulations), Australian Accounting Interpretations, other authoritative pronouncements of the Australian Accounting Standards Board, the *Local Government Act 1995* and accompanying regulations. Accounting policies which have been adopted in the preparation of this financial report have been consistently applied unless stated otherwise.

Except for cash flow and rate setting information, the report has been prepared on the accrual basis and is based on historical costs, modified, where applicable, by the measurement at fair value of selected non-current assets, financial assets and liabilities.

THE LOCAL GOVERNMENT REPORTING ENTITY

All Funds through which the Council controls resources to carry on its functions have been included in this statement. In the process of reporting on the local government as a single unit, all transactions and balances between those funds (for example, loans and transfers between Funds) have been eliminated.

SIGNIFICANT ACCOUNTING POLICIES

GOODS AND SERVICES TAX

Revenues, expenses and assets are recognised net of the amount of GST, except where the amount of GST incurred is not recoverable from the Australian Taxation Office (ATO). Receivables and payables are stated inclusive of GST receivable or payable. The net amount of GST recoverable from, or payable to, the ATO is included with receivables or payables in the statement of financial position. Cash flows are presented on a gross basis. The GST components of cash flows arising from investing or financing activities which are recoverable from, or payable to, the ATO are presented as operating cash flows.

CRITICAL ACCOUNTING ESTIMATES

The preparation of a financial report in conformity with Australian Accounting Standards requires management to make judgements, estimates and assumptions that effect the application of policies and reported amounts of assets and liabilities, income and expenses. The estimates and associated assumptions are based on historical experience and various other factors that are believed to be reasonable under the circumstances; the results of which form the basis of making the judgements about carrying values of assets and liabilities that are not readily apparent from other sources. Actual results may differ from these estimates.

ROUNDING OFF FIGURES

All figures shown in this statement are rounded to the nearest dollar.

**MONTHLY FINANCIAL REPORT
FOR THE PERIOD ENDED 31 MAY 2021**

**MONTHLY SUMMARY INFORMATION
GRAPHS**

OPERATING EXPENSES

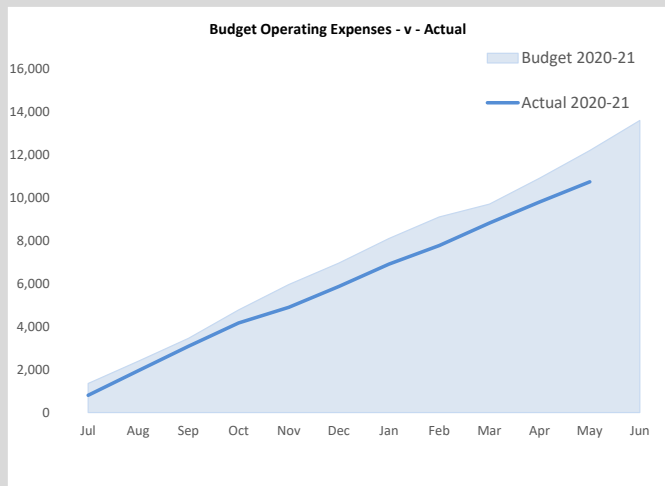

CAPITAL EXPENSES

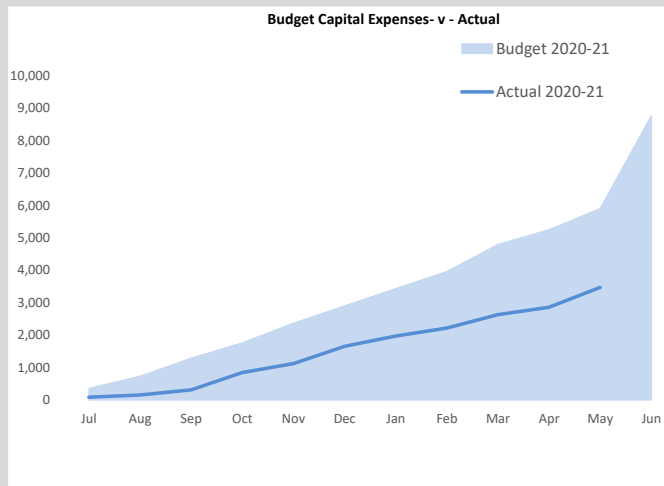

OPERATING REVENUE

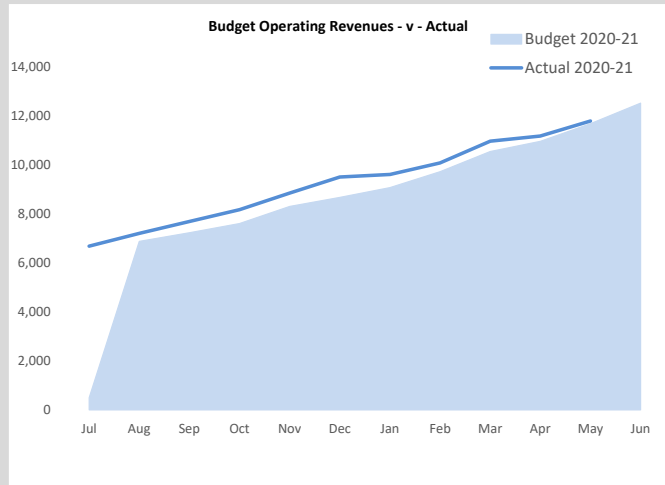

CAPITAL REVENUE

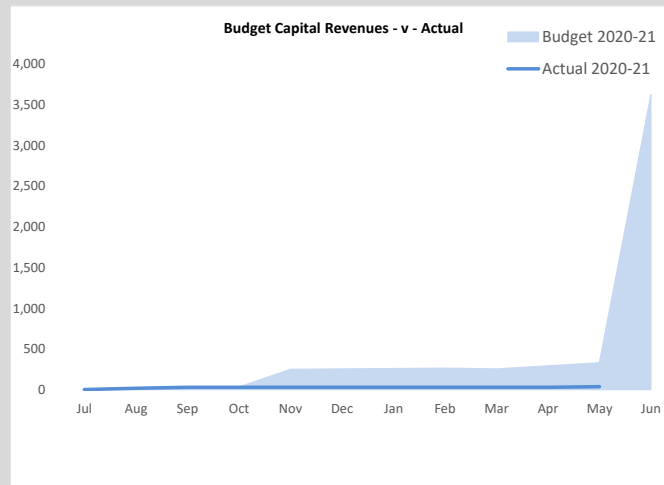

CAPITAL EXPENSES BY ACTIVITY

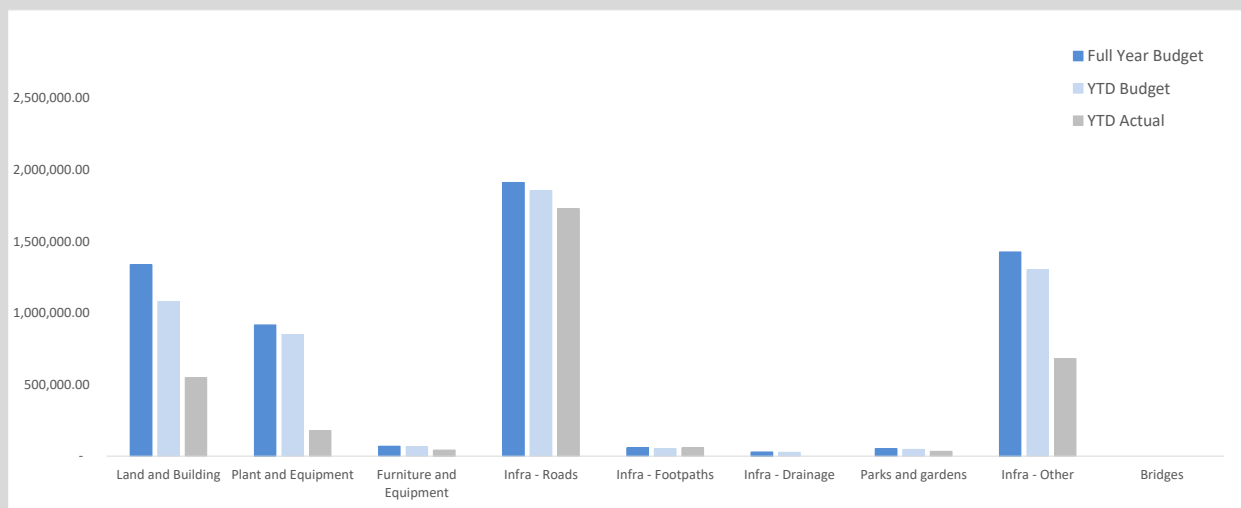

This information is to be read in conjunction with the accompanying Financial Statements and Notes.

STATEMENT OF FINANCIAL ACTIVITY
FOR THE PERIOD ENDED 31 MAY 2021

STATUTORY REPORTING PROGRAMS

	Ref Note	Adopted Annual Budget	Amended Annual Budget	YTD Budget (a)	YTD Actual (b)	Var. \$ (b)-(a)	Var. % (b)-(a)/(a)	Var.
		\$	\$	\$	\$	\$	%	
Opening Funding Surplus(Deficit)		2,697,512	2,557,686	2,557,686	2,557,686	0	(5%)	
Revenue from operating activities								
General Purpose Funding - Rates		4,941,453	4,929,289	4,932,639	4,929,595	(3,043)	(0%)	
General Purpose Funding - Other		1,388,346	1,307,424	1,299,474	1,304,806	5,333	0%	
Governance		1,850	7,752	5,859	6,249	391	7%	
Law, Order and Public Safety		285,505	467,305	430,695	403,528	(27,167)	(6%)	
Health		21,350	47,100	39,172	34,308	(4,863)	(12%)	
Education and Welfare		1,579,357	1,982,071	1,748,956	1,980,832	231,877	13%	▲
Housing		8,240	8,240	7,546	7,606	60	1%	
Community Amenities		1,145,512	1,109,800	988,948	1,090,801	101,854	10%	▲
Recreation and Culture		309,006	351,143	157,709	125,292	(32,417)	(21%)	▼
Transport		251,970	256,970	246,781	265,251	18,470	7%	
Economic Services		304,200	358,610	343,382	378,803	35,421	10%	▲
Other Property and Services		171,939	200,737	168,822	175,295	6,473	4%	
		10,408,728	11,026,441	10,369,980	10,702,369	332,388	3%	
Expenditure from operating activities								
General Purpose Funding		(248,012)	(265,448)	(246,838)	(282,201)	(35,363)	(14%)	▼
Governance		(648,647)	(631,147)	(490,971)	(406,365)	84,606	17%	▲
Law, Order and Public Safety		(755,988)	(989,578)	(851,699)	(648,472)	203,227	24%	▲
Health		(291,729)	(282,929)	(252,852)	(247,686)	5,166	2%	
Education and Welfare		(1,868,016)	(1,908,903)	(1,796,721)	(1,884,038)	(87,317)	(5%)	
Housing		(33,202)	(31,350)	(27,388)	(25,406)	1,982	7%	
Community Amenities		(1,570,941)	(1,526,348)	(1,343,904)	(1,209,102)	134,802	10%	▲
Recreation and Culture		(3,518,392)	(3,460,321)	(3,041,593)	(2,538,908)	502,686	17%	▲
Transport		(3,765,422)	(3,670,848)	(3,393,241)	(2,771,369)	621,873	18%	▲
Economic Services		(894,637)	(783,323)	(720,899)	(697,856)	23,043	3%	
Other Property and Services		(64,345)	(27,561)	(44,542)	(75,474)	(30,932)	(69%)	▼
		(13,659,333)	(13,577,757)	(12,210,649)	(10,786,877)	1,423,771		
Operating activities excluded from budget								
Add back Depreciation		3,450,264	3,450,264	3,162,632	2,675,391	(487,241)	(15%)	▼
Adjust (Profit)/Loss on Asset Disposal	12	129,582	129,579	114,369	2,722	(111,647)	(98%)	▼
Adjust Employee Benefits Provision (Non-Current)		0	0	0	0	0		
Adjust Deferred Pensioner Rates (Non-Current)		0	0	0	0	0		
Movement in Leave Reserve (Added Back)		0	0	0	0	0		
Adjust Rounding		0	0	0	0	0		
Amount attributable to operating activities		329,241	1,028,527	1,436,333	2,593,604	1,157,271		
Investing Activities								
Non-Operating Grants, Subsidies and Contributions		3,337,565	1,494,984	1,313,353	1,065,481	(247,873)	(19%)	▼
Land and Buildings	11	(2,794,757)	(1,335,973)	(1,079,385)	(547,553)	531,833	49%	▲
Plant and Equipment	11	(1,171,000)	(916,648)	(849,518)	(178,436)	671,081	79%	▲
Furniture and Equipment	11	(94,000)	(68,198)	(64,002)	(42,321)	21,681	34%	▲
Library Stock	11	0	0	0	0	0		
Infrastructure Assets - Roads	11	(1,900,181)	(1,910,335)	(1,853,226)	(1,727,070)	126,156	7%	
Infrastructure Assets - Footpaths	11	(81,360)	(57,579)	(51,944)	(58,247)	(6,303)	(12%)	
Infrastructure Assets - Road Drainage	11	(30,000)	(30,000)	(27,500)	0	27,500	100%	▲
Infrastructure Assets - Parks and Gardens	11	(45,000)	(51,500)	(46,114)	(32,779)	13,335	29%	
Infrastructure Assets - Bridges	11	(270,000)	0	0	0	0	0%	
Infrastructure Assets - Other	11	(1,470,017)	(1,425,219)	(1,301,341)	(681,342)	619,998	48%	▲
Proceeds from Disposal of Assets	12	592,000	432,454	55,076	54,031	(1,045)	(2%)	
Proceeds from Sale of Investments		0	0	0	0	0		
Amount attributable to investing activities		(3,926,750)	(3,868,014)	(3,904,600)	(2,148,236)	1,756,364		
Financing Activities								
Proceeds from New Debentures	13	180,000	180,000	180,000	0	(180,000)	(100%)	▼
Proceeds from Advances		0	0	0	0	0		
Repayment of Debentures	13	(173,652)	(173,652)	(165,136)	(172,101)	(6,965)	(4%)	
Self-Supporting Loan Principal		0	0	0	0	0		
Transfer from Reserves	10	3,139,700	3,010,336	95,567	0	(95,567)	(100%)	▲
Advances to Community Groups		0	0	0	0	0		
Transfer to Reserves	10	(2,300,170)	(2,734,884)	(421,201)	0	421,201	100%	▲
Amount attributable to financing activities		845,878	281,800	(310,770)	(172,101)	138,669		
Net Capital		(3,080,872)	(3,586,213)	(4,215,370)	(2,320,338)	1,895,032		
Total Net Operating + Capital		(2,751,631)	(2,557,687)	(2,779,037)	273,267	3,052,304		
Closing Funding Surplus(Deficit)	3	(54,119)	(0)	(221,351)	2,830,953	3,052,304		

KEY INFORMATION

▲ ▼ Indicates a variance between Year to Date (YTD) Budget and YTD Actual data as per the adopted materiality threshold.

Refer to Note 2 for an explanation of the reasons for the variance.

The material variance adopted by Council for the current year is \$15,000 or 10% whichever is the greater.

This statement is to be read in conjunction with the accompanying Financial Statements and notes.

**NOTES TO THE STATEMENT OF FINANCIAL ACTIVITY
FOR THE PERIOD ENDED 31 MAY 2021**

SIGNIFICANT ACCOUNTING POLICIES

CURRENT AND NON-CURRENT CLASSIFICATION

In the determination of whether an asset or liability is current or non-current, consideration is given to the time when each asset or liability is expected to be settled. The asset or liability is classified as current if it is expected to be settled within the next 12 months, being the Council's operational cycle. In the case of liabilities where Council does not have the unconditional right to defer settlement beyond 12 months, such as vested long service leave, the liability is classified as current even if not expected to be settled within the next 12 months. Inventories held for trading are classified as current even if not expected to be realised in the next 12 months except for land held for resale where it is held as non current based on Council's intentions to release for sale.

EMPLOYEE BENEFITS

The provisions for employee benefits relates to amounts expected to be paid for long service leave, annual leave, wages and salaries and are calculated as follows:

(i) Wages, Salaries, Annual Leave and Long Service Leave
(Short-term Benefits)

The provision for employees' benefits to wages, salaries, annual leave and long service leave expected to be settled within 12 months represents the amount the City has a present obligation to pay resulting from employees services provided to balance date. The provision has been calculated at nominal amounts based on remuneration rates the City expects to pay and includes related on-costs.

(ii) *Annual Leave and Long Service Leave (Long-term Benefits)*

The liability for long service leave is recognised in the provision for employee benefits and measured as the present value of expected future payments to be made in respect of services provided by employees up to the reporting date using the project unit credit method. Consideration is given to expected future wage and salary levels, experience of employee departures and periods of service. Expected future payments are discounted using market yields at the reporting date on national government bonds with terms to maturity and currency that match as closely as possible, the estimated future cash outflows. Where the City does not have the unconditional right to defer settlement beyond 12 months, the liability is recognised as a current liability.

PROVISIONS

Provisions are recognised when: The council has a present legal or constructive obligation as a result of past events; it is more likely than not that an outflow of resources will be required to settle the obligation; and the amount has been reliably estimated. Provisions are not recognised for future operating losses. Where there are a number of similar obligations, the likelihood that an outflow will be required in settlement is determined by considering the class of obligations as a whole. A provision is recognised even if the likelihood of an outflow with respect to any one of item included in the same class of obligations may be small.

INVENTORIES

Inventories are measured at the lower of cost and net realisable value. Net realisable value is the estimated selling price in the ordinary course of business less the estimated costs of completion and the estimated costs necessary to make the sale.

NOTES TO THE STATEMENT OF FINANCIAL ACTIVITY
FOR THE PERIOD ENDED 31 MAY 2021

OPERATING ACTIVITIES
ADJUSTED NET CURRENT ASSETS

	Last Years Closing	This Time Last Year	Year to Date Actual
	30 Jun 2020	31 May 2020	31 May 2021
Adjusted Net Current Assets			
	\$	\$	\$
Current Assets			
Cash Unrestricted	3,111,299	4,206,841	2,566,185
Cash Restricted - Reserves	4,083,821	4,236,260	4,087,484
Cash Restricted - Bonds/Deposits	27,908	30,281	29,511
Receivables - Rates and Rubbish, ESL, Excess Rates	308,697	388,345	362,400
Receivables - Other	239,879	166,066	217,523
Inventories	19,735	16,714	8,827
	7,791,339	9,044,507	7,271,930
Less: Current Liabilities			
Payables	(790,470)	(852,808)	(80,681)
Loan Liability	(173,653)	(46,104)	(1,552)
Provisions	(711,328)	(549,544)	(696,482)
	(1,675,451)	(1,448,456)	(778,714)
Net Current Asset Position	6,115,888	7,596,051	6,493,215
Less: Cash Restricted	(4,083,821)	(4,236,251)	(4,083,821)
Add Back: Component of Leave Liability not Required to be funded	360,583	335,392	360,583
Add Back: Current Loan Liability	173,653	46,104	1,552
Adjustment for Trust Transactions Within Muni	(8,615)	(10,989)	59,425
	2,557,687	3,730,308	2,830,953
Net Current Funding Position			

SIGNIFICANT ACCOUNTING POLICIES

Please see page 5 for information on significant accounting policies relating to Net Current Assets.

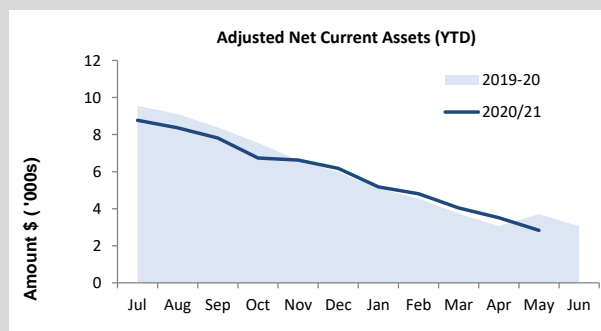

KEY INFORMATION

The amount of the adjusted net current assets at the end of the period represents the actual surplus (or deficit if the figure is a negative) as presented on the Rate Setting Statement.

Year YTD Actual
Surplus(Deficit)
\$2.83 M
This Time Last Year
Surplus(Deficit)
\$3.73 M

NOTE: For the Cash Assets above the following investments have been made as at reporting date:

Following recent maturity of some term deposits, new investments will be made soon to bring the portfolio into counterparty balance required by the Shire's Investment policy

	Investment Value \$	Maturity Date	Rate	Institution	Investment %
<u>Cash Restricted (Reserves)</u>					
NAB	2,000,000	3/06/2021	0.50%	NAB	100%
	<u>2,000,000</u>				<u>100%</u>

**NOTES TO THE STATEMENT OF FINANCIAL ACTIVITY
FOR THE PERIOD ENDED 31 MAY 2021**

**EXPLANATION OF
MATERIAL VARIANCES**

The material variance thresholds are adopted annually by Council as an indicator of whether the actual expenditure or revenue varies from the year to date. The material variance adopted by Council for the current year is an Actual Variance exceeding 10% and a value greater than \$15,000.

Reporting Program	Var. \$	Var. %	Var.	Timing/ Permanent	Explanation of Variance
	\$	%			
Revenue from operating activities					
Education and Welfare	231,877	13%	▲	Timing	Variance due to timing of the additional CHCP (\$175k) and CHSP(\$225k) recurrent grant funding.
Community Amenities	101,854	10%	▲	Timing	Variance due to timing of expenditure such as sewerage water treatment power costs (\$13k); environment protection employee costs (\$19k); townplanning and regional development (\$48k) and public conveniences maintenance(\$30k).
Recreation and Culture	(32,417)	(21%)	▼	Timing	Variance due to timing of capital contribution reimbursement income.
Economic Services	35,421	10%	▲	Permanent	Variance due to increased revenue from caravan park compared to adjusted budget (\$33k).
Expenditure from operating activities					
General Purpose Funding	(35,363)	(14%)	▼	Permanent	Variance due higher than anticipated AMPAC debt recovery expenditure incurred so far.
Governance	84,606	17%	▲	Timing	Variance due to timing of items and activities such as minor assets for members of council(\$6k), valuation expenses (\$8k); lower depreciation due to timing of capital expenditure (\$38k) and timing of elected member expenses and consulting (\$11k and 10k respectively).
Law, Order and Public Safety	203,227	24%	▲	Timing	Variance mainly due to timing of the fully funded Bushfire Risk Management expenditure (\$123k); Lower depreciation (\$16k); timing of overhead cost allocations(\$27k), and fire prevention costs(26k)and budgeted general expenses (\$10k)
Community Amenities	134,802	10%	▲	Timing	Variance due to timing of activities such as Town Planning(\$28k), landcare community projects (\$18k) toilets maintenance (\$30k), waste disposal and water treatment (\$47k), other community maintenance (30k).
Recreation and Culture	502,686	17%	▲	Timing	Variance due to timing of NRLC utilities expenditure (\$181k); reduced depreciation due to recent revision to recreational asset lives creating difference of (\$239k); timing of townhall maintenance and operation costs (\$21k), parks and garden maintenance (\$51k); halls and public buildings maintenance(\$23k) and Oval maintenance(\$26k).
Transport	621,873	18%	▲	Timing	Variance due to reduced depreciation associated with revision of some roading asset lives during 2019-20 year (\$304k); timing of road maintenance (\$111k), drainage maintenance (30k); timing of disposal of assets (\$40k), and overhead allocations (\$90k).
Other Property and Services	(30,932)	(69%)	▼	Timing	Variance due to timing of overhead allocations that includes admin allocation(16k) & Plant operating costs (14k).
Investing Activities					
Non-operating Grants, Subsidies and Contributions	(247,873)	(19%)	▼	Timing	Variance due to timing of state and commonwealth grants total, mainly due to heritage grant (180k) and regional road group (100k).
Capital Acquisitions	2,005,281	(38%)	▲	Timing	Variance due to timing of various capex, mainly the Railway Station Restoration for Covid Recovery expenditure (324k); John Deere Grader purchase (\$375k);TWIS dam (\$88k); Bowling Club (\$307k); various roads(\$300k); various plant (\$310k) and various buildings(\$155k) and upgradation & capital works of (170k).
Financing Activities					
Proceeds from New Debentures	(180,000)	(100%)	▼	Timing	Sewerage loan not yet obtained due to timing of associated Capital expenditure.
Transfer from Reserves	(95,567)	(100%)	▲	Timing	Transfers to take place at year end.
Transfer to Reserves	421,201	100%	▲	Timing	Variance due to timing of transfers to take place at year end.

KEY INFORMATION

▲▼ Indicates a variance between Year to Date (YTD) Budget and YTD Actual data as per the adopted materiality threshold.

▲ Favourable variance

▼ Unfavourable variance

This statement is to be read in conjunction with the accompanying Financial Statements and notes.

**NOTES TO THE STATEMENT OF FINANCIAL ACTIVITY
FOR THE PERIOD ENDED 31 MAY 2021**

**OPERATING ACTIVITIES
RECEIVABLES**

Rates Receivable	30 Jun 20	31 May 21
	\$	\$
Opening Arrears Previous Years	586,296	495,899
Levied this year	3,194,497	3,175,827
Movement in Excess Rates	0	0
Domestic Refuse Collection Charges	472,846	476,713
Domestic Services (Additional)	3,197	3,164
Commercial Collection Charge	0	43,427
Commercial Collection Charge (Additional)	43,793	43,264
Total Rates and Rubbish (YTD)	5,458,223	5,496,274
<u>Less Collections to date</u>	<u>(5,548,620)</u>	<u>(5,442,570)</u>
Net Rates Collectable	495,899	549,603
% Collected	91.80%	89.66%
Pensioner Deferred Rates		(178,755)
Pensioner Deferred ESL		(8,448)
Total Rates and Rubbish, ESL, Excess Rates		362,400

Receivables - General	Current	30 Days	60 Days	90+ Days	Total
	\$	\$	\$	\$	\$
Receivables - General	25,615	1,606	7,188	4,649	39,058
Percentage	1	0	0	0	
Balance per Trial Balance					
Rates Pensioner Rebate Claims					608
GST Input					50,392
Provision For Doubtful Debts					(27,544)
Total Receivables General Outstanding					62,514

Amounts shown above include GST (where applicable)

KEY INFORMATION

Trade and other receivables include amounts due from ratepayers for unpaid rates and service charges and other amounts due from third parties for goods sold and services performed in the ordinary course of business.

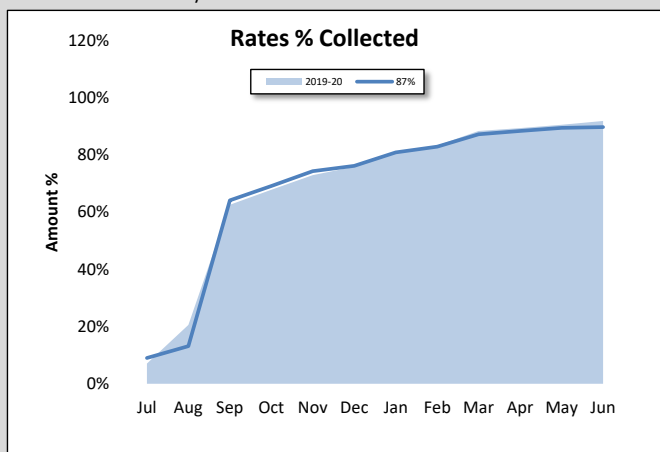

Collected	Rates Due
90%	\$362,400

SIGNIFICANT ACCOUNTING POLICIES

Trade and other receivables include amounts due from ratepayers for unpaid rates and service charges and other amounts due from third parties for goods sold and services performed in the ordinary course of business. Receivables expected to be collected within 12 months of the end of the reporting period are classified as current assets. All other receivables are classified as non-current assets. Collectability of trade and other receivables is reviewed on an ongoing basis. Debts that are known to be uncollectible are written off when identified. An allowance for doubtful debts is raised when there is objective evidence that they will not be collectible.

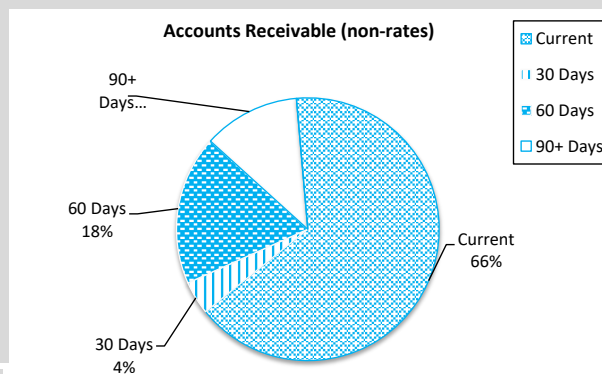

Debtors Due
\$62,514
Over 30 Days
34%
Over 90 Days
12%

**NOTES TO THE STATEMENT OF FINANCIAL ACTIVITY
FOR THE PERIOD ENDED 31 MAY 2021**

**INVESTING ACTIVITIES
CAPITAL ACQUISITIONS**

Capital Acquisitions	Current Budget	YTD Budget	YTD Actual Total	YTD Budget Variance
	\$	\$	\$	\$
Land and Buildings	1,335,973	1,079,385	547,553	531,833
Plant & Equipment	916,648	849,627	178,436	671,190
Furniture & Equipment	68,198	64,002	42,321	21,681
Roads	1,910,335	1,853,226	1,727,070	126,156
Footpaths	57,579	51,944	58,247	(6,303)
Road Drainage	30,000	27,500	0	27,500
Other Infrastructure	1,425,219	1,301,341	681,342	619,998
Parks and Gardens	51,500	46,114	32,779	13,335
Bridges	0	0	0	0
Capital Expenditure Totals	5,795,451	5,273,138	3,267,748	2,005,390

SIGNIFICANT ACCOUNTING POLICIES

All assets are initially recognised at cost. Cost is determined as the fair value of the assets given as consideration plus costs incidental to the acquisition. For assets acquired at no cost or for nominal consideration, cost is determined as fair value at the date of acquisition. The cost of non-current assets constructed by the local government includes the cost of all materials used in the construction, direct labour on the project and an appropriate proportion of variable and fixed overhead. Certain asset classes may be revalued on a regular basis such that the carrying values are not materially different from fair value. Assets carried at fair value are to be revalued with sufficient regularity to ensure the carrying amount does not differ materially from that determined using fair value at reporting date.

KEY INFORMATION

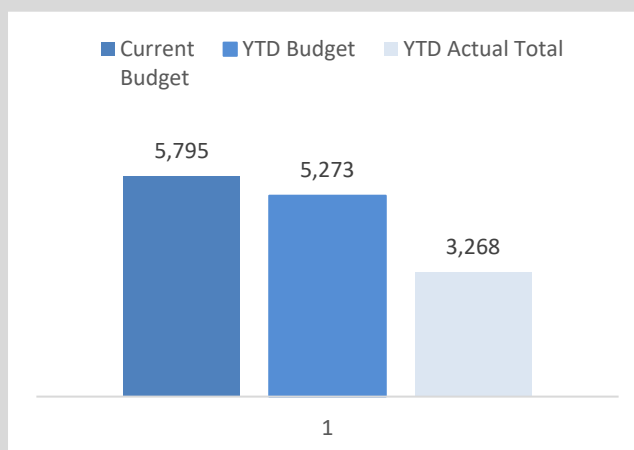

Acquisitions	Current Annual Budget	YTD Actual	% Spent
	\$5.8 M	\$3.27 M	56%





























To be read in conjunction with Strategic Projects Tracker

**NOTES TO THE STATEMENT OF FINANCIAL ACTIVITY
FOR THE PERIOD ENDED 31 MAY 2021**

**INVESTING ACTIVITIES
CAPITAL ACQUISITIONS (CONTINUED)**

% of Completion

Level of completion indicator, please see table at the end of this note for further detail.

	Account Number	JOB	Adopted Budget	Current Budget	YTD Budget	YTD Actual	YTD Variance Under(Over)
 HACC - Building (Capital)	4080360	BC050	70,000	40,925	42,356	43,198	(842)
 COM AMEN - Building (Capital) - CBD Ablution Upgrades	4100850	BC267	90,000	100,000	66,667	1,200	65,467
 Town Hall (Federal St) Building Capital	4110160	BC150	80,000	80,000	73,326	2,200	71,126
 NRLC Building (Capital)	4110260	BC160	30,000	30,000	27,500	29,324	(1,824)
 NRLC Building Capital 2018-19	4110260	BC161	40,000	40,000	36,663	0	36,663
 Library Building (Capital)	4110560	BC190	7,000	7,000	7,000	0	7,000
 Railway Station Building (Capital)	4110660	BC200	18,250	18,250	17,000	17,041	(41)
 Railway Station Resortation COVID recovery project	4110660	BC202	750,000	750,000	550,000	225,177	324,823
 Caravan Park Campers Kitchen Building Capital	4130260	BC234	5,000	5,000	5,000	888	4,112
 Strata- Old Shire Building	4130650	BC255	20,000	20,000	18,326	0	18,326
 30 Gray St Building upgrade	4130650	BC290	30,000	45,000	38,750	52,183	(13,433)
 Visitor Information Bay Upgrade (Williams Road)	4130260	IO094	8,000	8,000	8,000	2,113	5,888
 Admin Office Building Capital	4140560	BC260	13,000	25,000	22,000	7,431	14,569
			2,794,757	1,335,973	1,079,385	547,553	531,833
 NGN417 RO Vehicle	4050355	PA007A	44,000	44,000	44,000	43,142	858
 NO05 Ranger Vehicle 2020	4050355	PA8163B	45,000	45,000	45,000	52,392	(7,392)
 EHO Vehicle 2020	4070355	PA065B	30,000	24,273	23,205	24,273	(1,068)
 009NGN 2019 Toyota Camry Altise	4080455	PA043B	28,000	21,875	21,069	0	21,069
 NGN219 CATS Vehicle 2021	4080750	PA014H	28,000	28,000	25,663	0	25,663
 NRLC - Plant & Equipment Other (Capital)	4110255	PE161	17,500	17,500	16,038	11,130	4,908
 NO764 Bomag Twin Vibrating Roller	4120350	PA022A	45,000	45,000	41,250	47,500	(6,250)
 BT50 UTE 2020 (WORKS) (P62)	4120350	PA062A	30,000	30,000	27,500	0	27,500
 ONO EMTRS Vehicle 2020 (1)	4120350	PA700J	46,500	46,500	42,625	0	42,625
 ONO EMTRS Vehicle 2020 (2)	4120350	PA700K	46,500	46,500	42,625	0	42,625
 ONO EMTRS Vehicle 2021 (1)	4120350	PA700L	46,500	46,500	42,625	0	42,625
 ONO EMTRS Vehicle 2021 (2)	4120350	PA700M	46,500	46,500	42,625	0	42,625
 NOS91 Toyota Single Cab 4x4	4120350	PA8144A	35,000	35,000	32,076	0	32,076
 NO023 Toyota Dual Cab 4x4	4120350	PA8165A	30,000	30,000	27,500	0	27,500
 NO4719 John Deere Grader	4120350	PA978B	410,000	410,000	375,826	0	375,826

**NOTES TO THE STATEMENT OF FINANCIAL ACTIVITY
FOR THE PERIOD ENDED 31 MAY 2021**

**INVESTING ACTIVITIES
CAPITAL ACQUISITIONS (CONTINUED)**

% of Completion

Level of completion indicator, please see table at the end of this note for further detail.





















	Account Number	JOB	Adopted Budget	Current Budget	YTD Budget	YTD Actual	YTD Variance Under(Over)
			1,171,000	916,648	849,627	178,436	671,190
Governance Furniture & Equipment Replacements	4040250	FE028	5,000	5,000	5,000	570	4,430
Computer Purchases	4080350	FE031	10,000	3,198	4,002	2,570	1,432
ADMIN - IT Software & Equipment (Capital)	4140580	FE100	60,000	60,000	55,000	39,181	15,820
			94,000	68,198	64,002	42,321	21,681
Earl Street - Renewal (Local)	4120165	IR002	29,400	16,000	19,350	15,323	4,027
Moss Street - Upgrade (Local)	4120165	IR130	93,528	93,528	93,528	46,764	46,764
Whinbin Rock Road - Renewal (Rural)	4120165	IR205	93,358	93,358	93,356	117,426	(24,070)
Dongolocking Road - Upgrade (Rural)	4120165	IR209	101,846	117,846	109,243	92,544	16,699
Narragin Valley Road - Renewal (Rural)	4120165	IR212	170,224	170,224	170,224	94,832	75,392
Narrakine Road South - Upgrade (Rural)	4120165	IR221	77,008	77,008	77,008	73,942	3,066
Parks Road Renewal (Capital)	4120165	IR281	52,871	52,871	52,868	47,983	4,885
Graham Road - Renewal (Local)	4120165	IR303	95,607	95,607	95,604	54,814	40,790
Street Tree Capital	4120165	IRTREE	20,000	27,554	20,666	22,342	(1,676)
Bannister St Renewal (R2R)	4120166	R2R003	23,555	23,555	21,582	25,483	(3,901)
Bunbury St Renewal (R2R)	4120166	R2R006	4,884	4,884	4,477	5,284	(807)
Smith Street - Renewal (Local) (R2R)	4120166	R2R020	54,950	54,950	50,369	36,472	13,897
Homer Street - Renewal (Local) (R2R)	4120166	R2R024	7,970	7,970	7,304	8,622	(1,318)
Gregory St Renewal (R2R)	4120166	R2R026	3,749	3,749	3,432	4,056	(624)
Hansard Street - Renewal (Local) (R2R)	4120166	R2R028	7,560	7,560	6,930	8,179	(1,249)
Heath Street - Renewal (Local) (R2R)	4120166	R2R040	1,898	1,898	1,738	2,053	(315)
Scotts St Renewal (R2R)	4120166	R2R049	4,158	4,158	3,806	4,498	(692)
Francis Street - Renewal (Local) (R2R)	4120166	R2R054	4,432	4,432	4,059	4,795	(736)
Grainger St Renewal (R2R)	4120166	R2R071	9,009	9,009	8,250	9,746	(1,496)
Olden St Renewal (R2R)	4120166	R2R078	2,772	2,772	2,541	2,999	(458)
Keally St Renewal (R2R)	4120166	R2R087	4,138	4,138	3,784	4,477	(693)
Yale Pl Renewal (R2R)	4120166	R2R091	3,340	3,340	3,058	3,613	(555)
Hughes St Renewal (R2R)	4120166	R2R092	4,554	4,554	4,169	4,927	(758)
William Kenndey Way Renewal (R2R)	4120166	R2R100	23,380	23,380	21,428	13,636	7,792
Narrakine Road - Renewal (R2R)	4120166	R2R112C	52,830	52,830	48,422	81,145	(32,723)
Parry Crt Renewal (R2R)	4120166	R2R115	3,960	3,960	3,630	4,284	(654)
Congelin Rd Renewal (R2R)	4120166	R2R203	26,790	26,790	24,552	29,680	(5,128)
Normans Lake Siding Rd Renewal (R2R)	4120166	R2R255	59,998	59,998	54,989	62,740	(7,751)
Narragin-Harrismith Road - Renewal (Local) (R2R)	4120166	R2R331	29,914	29,914	27,412	28,812	(1,400)
Ried Rd Renewal (R2R)	4120166	R2R333	45,000	45,000	41,239	43,342	(2,103)
Wagin-Wickepin Road - Renewal (Rural) (RRG)	4120167	RRG207	787,500	787,499	774,208	772,262	1,946
			1,900,181	1,910,335	1,853,226	1,727,070	126,156
Argus Street Footpath Construction	4120175	IF038	48,000	30,768	26,276	30,768	(4,492)
Park Street Footpath Construction	4120175	IF052	27,360	20,811	20,168	22,669	(2,501)
Memorial Park Footpath Construction	4120175	IF102	6,000	6,000	5,500	4,810	690
			81,360	57,579	51,944	58,247	(6,303)
Drainage Works	4120180	ID000	30,000	30,000	27,500	0	27,500
			30,000	30,000	27,500	0	27,500
White Road Refuse Site	4110165	IO024	10,000	10,000	10,000	0	10,000
Bin Surrounds	4110165	IO085	18,000	23,260	21,945	12,338	9,607
TWIS Dams	4100350	IO078	180,000	180,000	180,000	91,473	88,527
Drainage Engineering consultancy - stormwater diversion	4100450	IO119	13,610	13,000	13,000	11,397	1,603
Cemetery Upgrade	4100860	IO026	15,000	15,000	15,000	1,600	13,400
CBD Design - Colour Palette and signage	4100860	IO100	15,000	15,000	13,750	0	13,750

**NOTES TO THE STATEMENT OF FINANCIAL ACTIVITY
FOR THE PERIOD ENDED 31 MAY 2021**

**INVESTING ACTIVITIES
CAPITAL ACQUISITIONS (CONTINUED)**

% of Completion

Level of completion indicator, please see table at the end of this note for further detail.

	Account Number	JOB	Adopted Budget	Current Budget	YTD Budget	YTD Actual	YTD Variance Under(Over)
	Gnarojin Park Cultural Heritage Management Plan	IO108	10,440	10,440	9,570	5,186	4,384
	Gnarojin Park Electrical Design Work	IO109	33,000	33,000	30,250	0	30,250
	Gnarojin Park Landscape Design	IO110	95,000	95,000	87,076	0	87,076
	NRLC Infrastructure Other (Capital)	IO160	83,000	84,950	77,538	90,057	(12,519)
	NRLC - Infrastructure Other (Capital - Outside)	IO161	132,398	100,000	97,065	99,866	(2,801)
	NRLC - Infrastructure Other (Capital - Inside)	IO162	150,000	136,000	127,000	148,636	(21,636)
	Railway Dam	IO018	61,000	53,000	49,913	65,965	(16,052)
	Bowling Club Capital Projects	IO029	335,109	335,109	307,175	0	307,175
	Highbury Tennis Court	IO093	50,000	50,000	45,826	42,500	3,326
	Gnarojin Community Garden Projects	IO101	10,000	13,000	11,413	11,448	(35)
	Gnarojin Park Hydrology Report	IO117	15,510	15,510	14,223	5,274	8,949
	Projects NEXIS (Capital)	IO150	27,630	27,630	25,322	0	25,322
	Street Furniture	IO014	18,000	18,000	16,500	8,128	8,372
	IO Fencing Projects (Capital)	IO022	15,000	15,000	13,750	0	13,750
	Carpark Renewals (Capital)	IO023	17,320	17,320	15,873	11,123	4,750
	DEPOT Rainwater Tank 120,000Lt	IO250	20,000	20,000	18,326	11,238	7,088
	Caravan Park Resealing, Line Marking	IO081	110,000	110,000	100,826	48,312	52,514
			1,470,017	1,425,219	1,301,341	681,342	619,998
	Park Furniture (Capital)	IO174	35,000	35,000	32,076	21,586	10,490
	Highbury Tennis Club	IO176	0	6,500	4,875	0	4,875
	Street & Parks Solar Lighting (Capital)	IO175	10,000	10,000	9,163	11,193	(2,030)
			45,000	51,500	46,114	32,779	13,335
	Grand Total		7,856,315	5,795,451	5,273,138	3,267,748	2,005,390

Capital Expenditure Total

Level of Completion Indicators

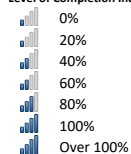

Percentage YTD Actual to Revised Budget
Expenditure over budget highlighted in red.

Variance is calculated on:
YTD Budget vs YTD Actual

NOTES TO THE STATEMENT OF FINANCIAL ACTIVITY
FOR THE PERIOD ENDED 31 MAY 2021

OPERATING ACTIVITIES
CASH AND INVESTMENTS

Cash Backed Reserve

Reserve Name	Opening Balance	Current Budget Interest Earned	Actual Interest Earned	Current Budget Transfers In (+)	Actual Transfers In (+)	Current Budget Transfers Out (-)	Actual Transfers Out (-)	Current Budget Closing Balance	Actual YTD Closing Balance
	\$	\$	\$	\$	\$	\$	\$	\$	\$
Refuse	478,789	2,675	0	50,213	0	35,076	0	496,601	478,789
CAT Vehicle Replacement	794	2,053	0	13,000	0	13,000	0	2,847	794
Building	470,148	1,943	0	0	0	205,198	0	266,893	470,148
Employee Entitlement	360,583	1,293	0	0	0	0	0	361,876	360,583
Plant, Vehicle & Equipment	395,308	1,274	0	425,000	0	488,000	0	333,582	395,308
Economic Development	227,022	1,591	0	0	0	208,089	0	20,524	227,022
NRLC	279,436	447	0	201,000	0	215,000	0	265,883	279,436
Tourism & Area Promotion	78,521	2,800	0	0	0	0	0	81,321	78,521
HACC	523,586	238	0	41,554	0	118,928	0	446,450	523,586
CHCP	222,234	2,480	0	802,426	0	526,640	0	500,500	222,234
CHSP	291,306	449	0	1,096,190	0	1,080,405	0	307,540	291,306
IT & Office Equipment	78,802	1,908	0	0	0	60,000	0	20,710	78,802
Road Construction	335,003	0	0	0	0	0	0	335,003	335,003
Asset Valuation	31,844	562	0	0	0	0	0	32,406	31,844
Unspent Grants and Contributions	186,594	0	0	0	0	0	0	186,594	186,594
Landcare	98,681	144	0	0	0	25,000	0	73,825	98,681
Narrogin Airport	25,171	144	0	15,000	0	0	0	40,315	25,171
Water Reuse Schemes	0	0	0	17,500	0	0	0	17,500	0
Bridges	0	0	0	48,000	0	35,000	0	13,000	0
	4,083,821	20,001	0	2,709,883	0	3,010,336	0	3,803,369	4,083,821

KEY INFORMATION

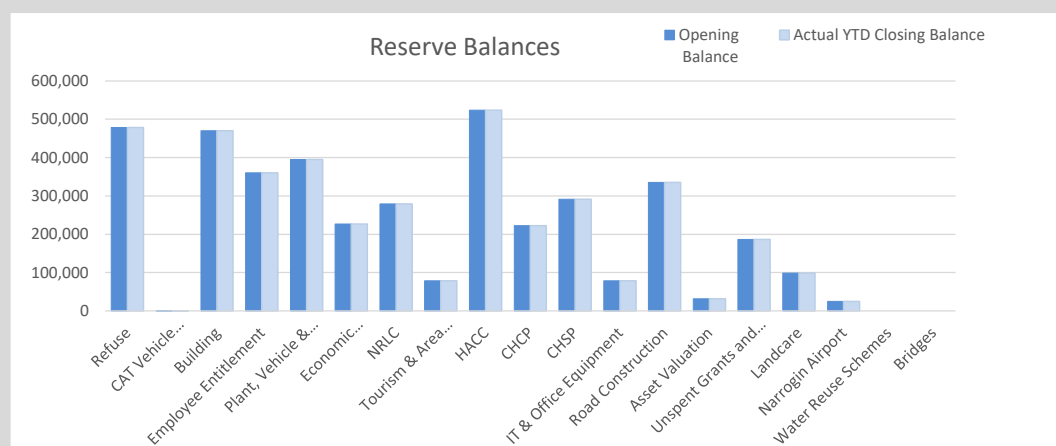

**NOTES TO THE STATEMENT OF FINANCIAL ACTIVITY
FOR THE PERIOD ENDED 31 MAY 2021**

BUDGET AMENDMENTS

Amendments to original budget since budget adoption. Surplus/(Deficit)

Date	GL / Job Number	Description	Council Resolution	Classification	Non Cash Adjustment	Increase in Available Cash	Decrease in Available Cash	Amended Budget Running Balance
Oct-20	2100501	Landcare Community Projects		Operating expenses	\$	\$	\$	\$
Oct-20	IO117	Gnarogin Park Hydrology Report		Capital expenditure			(25,000)	(25,000)
Oct-20	IO119	Drainage Engineering Consultancy		Capital expenditure			(15,510)	(40,510)
Oct-20	5110152	HALLS - Grants and contributions		Capital income			(13,610)	(54,120)
Oct-20	5110252	NRLC Club contributions		Capital income			(25,000)	(79,120)
Oct-20	5110254	OTHER-Other Contributions reimbursements		Capital income			(15,000)	(94,120)
Oct-20	21302000	TOUR - Public Relations & Area Promotions		Operating expenses		110,000	(50,000)	(144,120)
Oct-20		Opening surplus readjusted following year end adjustments		Opening surplus		34,120		(34,120)
Nov-20	2080590	CHSP Refund of Unspent Grant Funding		Operating expenses			110,000	0
Nov-20	5080552	CHSP - Transfer from Reserve		Capital income		116,393		116,393
Nov-20	2050120	FIRE-Bushfire Risk Management Plan		Operating expenses			(116,393)	(116,393)
Nov-20	3050104	FIRE- Grants		Operating Revenue		184,500		184,500
		Opening surplus readjusted following year end adjustments		Opening surplus			(184,500)	0
Mar-21	2030105	RATES - Rates Incentive Scheme		Operating expenses			(174,506)	(174,506)
Mar-21	2030106	RATES - Valuation Expenses		Operating expenses		4,000	(773)	(175,279)
Mar-21	2030115	RATES - Consultants		Operating expenses			(17,663)	(188,942)
Mar-21	2030199	RATES - Administration Allocated		Operating expenses			(5,000)	(193,942)
Mar-21	3030100	RATES - Rates Levied - GRV		Operating Revenue			(8,229)	(202,171)
Mar-21	3030110	RATES - Interim Rates Levied - GRV		Operating Revenue			(7,307)	(209,478)
Mar-21	3030115	RATES - Back Rates Levied - GRV		Operating Revenue		3,373		(206,105)
Mar-21	3030128	RATES - Instalment Admin Fee Received		Operating Revenue		14,337		(191,768)
Mar-21	3030132	RATES - Special Payment Arrangement		Operating Revenue			(9,000)	(200,768)
Mar-21	3030200	GENGRANT - Financial Assistance Grant - General		Operating Revenue			(15,813)	(216,581)
Mar-21	3030201	GENGRANT - Financial Assistance Grant - Roads		Operating Revenue			(12,446)	(229,027)
Mar-21	2030300	INVEST - Bank Fees and Charges (Inc GST)		Operating expenses		2,000		(227,027)
Mar-21	3030300	INVEST - Interest Earned - Reserve Funds		Operating Revenue			(40,000)	(267,027)
Mar-21	3030301	INVEST - Interest Earned - Municipal Funds		Operating Revenue			(18,000)	(285,027)
Mar-21	4030350	INVEST - Transfer Interest To Reserve		Capital income		40,000		(245,027)
Mar-21	2040107	MEMBERS - Members Conference/Training Expenses		Operating expenses		9,000		(236,027)
Mar-21	2040112	MEMBERS - Election Expenses		Operating expenses		3,000		(233,027)
Mar-21	2040116	MEMBERS - Advertising & Promotions		Operating expenses		5,000		(228,027)
Mar-21	2040199	MEMBERS - Administration Allocated		Operating expenses			(7,000)	(235,027)
Mar-21	2040216	OTHGOV - Legal Expenses		Operating expenses		7,500		(227,527)
Mar-21	3040206	OTHGOV - Sundry Income - Other Governance		Operating Revenue		2,743		(224,784)
Mar-21	3040299	Suspense Holding for Electronic Bank Deposits		Operating Revenue		3,159		(221,625)
Mar-21	LB011	Building Renovation Administration		Capital Expenditure		26,297		(195,328)
Mar-21	5040260	OTHGOV - Transfer From Reserves		Capital Income			(26,297)	(221,625)
Mar-21	2050100	FIRE - Salaries & Wages		Operating expenses		7,500		(214,125)
Mar-21	2050105	FIRE- Protective Clothing		Operating expenses		2,000		(212,125)
Mar-21	2050107	FIRE - Motor Vehicle Expenses		Operating expenses			(10,905)	(223,030)
Mar-21	2050199	FIRE - Administration Allocated		Operating expenses			(3,500)	(226,530)
Mar-21	BC020	Fire Prevention Building (Capital)		Capital Expenditure		1,500,000		1,273,470
Mar-21	5050152	FIRE - Grants (State)		Capital Income			(1,500,000)	(226,530)
Mar-21	BC265	Ses Training / Meeting Room		Capital Expenditure		62,210		(164,320)

Date	GL / Job Number	Description	Council Resolution	Classification	Non Cash Adjustment	Increase in Available Cash	Decrease in Available Cash	Amended Budget Running Balance
Mar-21	5050250	ESL - Transfer from Reserve		Capital Income			(62,210)	(226,530)
Mar-21	2050300	ANIMAL - Salaries & Wages		Operating expenses			(29,353)	(255,883)
Mar-21	3050302	ANIMAL - Fines and Penalties		Operating Revenue			(2,700)	(258,583)
Mar-21	PD007C	Proceeds On Disposal - Ranger Vehicle 2018		Capital Income		5,000		(253,583)
Mar-21	2050400	OLOPS - Salaries & Wages		Operating expenses			(8,167)	(261,750)
Mar-21	2050410	OLOPS - Insurance		Operating expenses			(3,168)	(264,918)
Mar-21	2050499	OLOPS - Administration Allocated		Operating expenses			(3,500)	(268,418)
Mar-21	2070307	HEALTH - Legal Expenses		Operating expenses		2,000		(266,418)
Mar-21	2070310	HEALTH - Control Expenses		Operating expenses			(1,500)	(267,918)
Mar-21	3070302	HEALTH - Health Regulatory Fines and Penalties		Operating Revenue		25,750		(242,168)
Mar-21	PA065B	Eho Vehicle 2020		Capital Expenditure		5,727		(236,441)
Mar-21	2070610	OTH HEALTH - COVID19 Expenses		Operating expenses		14,800		(221,641)
Mar-21	CV0002	Other Purchases For Cv19 Reponse		Operating expenses			(6,500)	(228,141)
Mar-21	2080300	HACC - Salaries & Wages		Operating expenses		35,933		(192,208)
Mar-21	2080311	HACC - Subscriptions & Memberships		Operating expenses			(1,700)	(193,908)
Mar-21	2080314	HACC - Motor Vehicles Expenses		Operating expenses		2,822		(191,086)
Mar-21	2080320	HACC - General Office Expenses		Operating expenses		5,226		(185,860)
Mar-21	2080322	HACC - Sundry Expenditure		Operating expenses			(1,048)	(186,908)
Mar-21	2080331	HACC - Building Water		Operating expenses		4,316		(182,592)
Mar-21	HACC030	Hacc Personal Care Salaries		Operating expenses		1,117		(181,475)
Mar-21	HACC060	Hacc Social Support Salaries		Operating expenses		1,382		(180,093)
Mar-21	HACC070	Hacc Home Mtce Salaries		Operating expenses		1,215		(178,878)
Mar-21	FE031	Computer Purchases		Capital Expenditure		6,802		(172,076)
Mar-21	BC050	Hacc - Building (Capital)		Capital Expenditure		29,075		(143,001)
Mar-21	BC051	Hacc - Building Cctv		Capital Expenditure		10,000		(133,001)
Mar-21	4080370	HACC - Transfers To Reserve		Capital Expenditure			(5,000)	(138,001)
Mar-21	5080352	HACC - Transfers From Reserve		Capital Income			(95,141)	(233,142)
Mar-21	3080301	HACC - Non-Recurrent Grant Funding		Capital Income		5,000		(228,142)
Mar-21	CHCP110	Chcp Respite Salary		Operating expenses			(38,036)	(266,178)
Mar-21	2080400	CHCP - Salaries & Wages		Operating expenses		11,572		(254,606)
Mar-21	2080401	CHCP - Superannuation		Operating expenses			(5,500)	(260,106)
Mar-21	2080435	CHCP -Client Purchases		Operating expenses			(19,500)	(279,606)
Mar-21	CHCP002	Chcp Customer Services Superannuation		Operating expenses		8,359		(271,247)
Mar-21	CHCP010	Chcp Assessments Salaries		Operating expenses			(13,034)	(284,281)
Mar-21	CHCP011	Chcp Assessments Superannuation		Operating expenses		3,325		(280,956)
Mar-21	CHCP030	Chcp Personal Care Salaries		Operating expenses		3,734		(277,222)
Mar-21	CHCP031	Chcp Personal Care Superannuation		Operating expenses		5,925		(271,297)
Mar-21	CHCP040	Chcp Domestic Assistance Salaries		Operating expenses			(4,310)	(275,607)
Mar-21	CHCP041	Chcp Domestic Assistance Superannuation		Operating expenses			(3,730)	(279,337)
Mar-21	CHCP060	Chcp Social Support Salaries		Operating expenses			(1,790)	(281,127)
Mar-21	CHCP070	Chcp Home Mtce Salaries		Operating expenses			(5,787)	(286,914)
Mar-21	CHCP071	Chcp Home Mtce Superannuation		Operating expenses			(10,766)	(297,680)
Mar-21	CHCP120	Chcp Client Care Coordination Salaries		Operating expenses			(16,944)	(314,624)
Mar-21	CHCP121	Chcp Client Care Coordination Superannuation		Operating expenses		2,564		(312,060)
Mar-21	CHCP135	Chcp Food Services		Operating expenses			(2,210)	(314,270)
Mar-21	2080490	CHCP - Refund of Unspent Monies		Operating expenses		21,000		(293,270)
Mar-21	2081999	CHCP - Unrecoverable Fees and Charges		Operating expenses		5,000		(288,270)
Mar-21	3080400	CHCP - Recurrent Grant Funding		Operating Revenue		100,091		(188,179)
Mar-21	3080402	CHCP - CDC User Charges		Operating Revenue			(68,562)	(256,741)
Mar-21	3080405	CHCP - Other Grants		Operating Revenue		10,909		(245,832)

Date	GL / Job Number	Description	Council Resolution	Classification	Non Cash Adjustment	Increase in Available Cash	Decrease in Available Cash	Amended Budget Running Balance
Mar-21	4080470	CHCP - Transfers To Reserve		Capital Expenditure			(42,438)	(288,270)
Mar-21	PA043A	Proceeds On Disposal - 009Ngn 2017 Toyota Camry Altise		Capital Income			(2,546)	(290,816)
Mar-21	PA043B	009NGN 2019 Toyota Camry Altise		Capital Expenditure		6,125		(284,691)
Mar-21	5080452	CHCP - Transfers From Reserve		Capital Income		54,225		(230,466)
Mar-21	2080500	CHSP - Salaries & Wages		Operating expenses		14,211		(216,255)
Mar-21	2080504	CHSP - Training & Development		Operating expenses			(3,000)	(219,255)
Mar-21	2080513	CHSP - Information Systems		Operating expenses			(3,700)	(222,955)
Mar-21	2080514	CHSP - Motor Vehicles Expenses		Operating expenses		22,027		(200,928)
Mar-21	2080516	CHSP - Telephones / Mobiles		Operating expenses		3,200		(197,728)
Mar-21	2080535	CHSP - Audit Fees		Operating expenses		1,620		(196,108)
Mar-21	CHSP001	Chsp Customer Services Salaries		Operating expenses			(40,000)	(236,108)
Mar-21	CHSP002	Chsp Customer Services Superannuation		Operating expenses		21,374		(214,734)
Mar-21	CHSP010	Chsp Respite Care Salaries		Operating expenses		16,585		(198,149)
Mar-21	CHSP011	Chsp Respite Care Superannuation		Operating expenses		3,325		(194,824)
Mar-21	CHSP030	Chsp Personal Care Salaries		Operating expenses		26,592		(168,232)
Mar-21	CHSP031	Chsp Personal Care Superannuation		Operating expenses		5,130		(163,102)
Mar-21	CHSP040	Chsp Domestic Assistance Salaries		Operating expenses		27,716		(135,386)
Mar-21	CHSP041	Chsp Domestic Assistance Superannuation		Operating expenses			(1,175)	(136,561)
Mar-21	CHSP060	Chsp Social Support Salaries		Operating expenses			(70,823)	(207,384)
Mar-21	CHSP061	Chsp Social Support Superannuation		Operating expenses		4,336		(203,048)
Mar-21	CHSP070	Chsp Home Maintenance Salaries		Operating expenses			(6,335)	(209,383)
Mar-21	CHSP071	Chsp Home Maintenance Superannuation		Operating expenses			(2,896)	(212,279)
Mar-21	CHSP080	Chsp Transport Salaries		Operating expenses		12,453		(199,826)
Mar-21	CHSP090	Chsp Social Support Group Salaries		Operating expenses		28,621		(171,206)
Mar-21	CHSP091	Chsp Social Support Group Superannuation		Operating expenses		5,160		(166,046)
Mar-21	CHSP094	Chsp Social Support Group Venue Hire		Operating expenses		4,500		(161,546)
Mar-21	CHSP098	Chsp Social Support Group Other Expenses		Operating expenses		4,500		(157,046)
Mar-21	CHSP111	Chsp Respite Care Superannuation		Operating expenses		4,193		(152,853)
Mar-21	CHSP132	Chsp Meals On Wheels Catering Contract		Operating expenses		4,000		(148,853)
Mar-21	CHSP133	Chsp Meals On Wheels Committee		Operating expenses			(700)	(149,553)
Mar-21	3080500	CHSP - Recurrent Grant Funding		Operating Revenue		351,276		201,723
Mar-21	3080513	CHSP - User Charges - Personal Care		Operating Revenue			(2,000)	199,723
Mar-21	3080517	CHSP - User Charges - Home Maintenance		Operating Revenue		2,000		201,723
Mar-21	4080570	CHSP - Transfers To Reserve		Capital Expenditure			(351,276)	(149,553)
Mar-21	5080552	CHSP - Transfers From Reserve		Capital Income			(81,389)	(230,942)
Mar-21	2080709	AGEOTHER - Brokered in Exps		Operating expenses			(12,542)	(243,484)
Mar-21	3080713	AGEOTHER - Commonwealth Carers Respite Fees & Charges		Operating Revenue			(4,000)	(247,484)
Mar-21	3080715	Brokered Out Revenue		Operating Revenue		13,000		(234,484)
Mar-21	2080801	WELFARE - Youth Services		Operating expenses		18,000		(216,484)
Mar-21	BO100	Ceo Staff Housing Rental Property Expenses		Operating expenses			(1,149)	(217,633)
Mar-21	BM110	13 Hough St - Maintenance		Operating expenses		3,000		(214,633)
Mar-21	2100101	SAN - Waste Disposal		Operating expenses		25,693		(188,940)
Mar-21	2100103	SAN - Regional Waste		Operating expenses		5,000		(183,940)
Mar-21	BO120	Waste Facilities Building Operations		Operating expenses		3,750		(180,190)
Mar-21	3100100	SAN - Domestic Refuse Collection Charges		Operating Revenue		2,475		(177,715)
Mar-21	3100103	SAN - Reimbursements		Operating Revenue			(3,000)	(180,715)
Mar-21	IO085	Bin Surrounds		Capital Expenditure			(5,260)	(185,975)
Mar-21	5100150	SAN - Transfer from Reserves		Capital Income			(57,644)	(243,619)
Mar-21	2100201	SANOTH - Waste Disposal		Operating expenses		21,178		(222,441)
Mar-21	3100202	SANOTH - Commercial Tipping Charge		Operating Revenue		5,000		(217,441)

Date	GL / Job Number	Description	Council Resolution	Classification	Non Cash Adjustment	Increase in Available Cash	Decrease in Available Cash	Amended Budget Running Balance
Mar-21	2100310	SEW interest on Loan #130		Operating expenses		2,250		(215,191)
Mar-21	2100399	SEW - Administration Allocated		Operating expenses			(5,000)	(220,191)
Mar-21	3100300	SEW - Waste Water Charges		Operating Revenue			(51,000)	(271,191)
Mar-21	3100302	Sundry Income		Operating Revenue		12,813		(258,378)
Mar-21	IO119	Drainage Engineering Consultancy - Stormwater Diversion		Capital Expenditure		610		(257,768)
Mar-21	3100600	PLAN - Planning Application Fees		Operating Revenue			(7,000)	(264,768)
Mar-21	3100605	PLAN - Orders & Requisitions		Operating Revenue		5,000		(259,768)
Mar-21	PA002K	Ngn00 Emdrs Vehicle 2020(2)		Capital Expenditure		46,500		(213,268)
Mar-21	PA002L	Ngn00 Emdrs Vehicle 2021(1)		Capital Expenditure		46,500		(166,768)
Mar-21	PA002M	Ngn00 Emdrs Vehicle 2021(2)		Capital Expenditure		46,500		(120,268)
Mar-21	PD002J	Proceeds On Disposal - Emdrs Vehicle 2020(1)		Capital Income			(42,000)	(162,268)
Mar-21	PD002K	Proceeds On Disposal - Emdrs Vehicle 2020(2)		Capital Income			(45,000)	(207,268)
Mar-21	PD002L	Proceeds On Disposal - Emdrs Vehicle 2021(1)		Capital Income			(45,000)	(252,268)
Mar-21	5110065	PLAN - Transfer From Reserves GEN		Capital Income			(7,500)	(259,768)
Mar-21	BO130	Mackie Park Public Toilets And Office Operations		Operating expenses			(2,291)	(262,059)
Mar-21	BO131	Gnarojin Park Public Toilets Operations		Operating expenses			(2,262)	(264,321)
Mar-21	BO132	Smith St Public Toilets (Coles Carpark) Operations		Operating expenses			(2,262)	(266,582)
Mar-21	BO135	May St Public Toilets Operations		Operating expenses		1,361		(265,221)
Mar-21	BM135	May St Public Toilets Maintenance		Operating expenses			(2,825)	(268,046)
Mar-21	BC176	May Street Public Toilet Upgrade		Capital Expenditure			(63,198)	(331,244)
Mar-21	BC267	Com Amen - Building (Capital) - Cbd Ablution Upgrades		Capital Expenditure			(10,000)	(341,244)
Mar-21	5100850	COM AMEN - Transfer from Reserve		Capital Income		73,198		(268,046)
Mar-21	BO150	Town Hall (Federal St) Building Operations		Operating expenses		2,290		(265,756)
Mar-21	BO151	Railway Institute Hall & Office Building Operations		Operating expenses			(2,480)	(268,236)
Mar-21	BO152	John Higgins Community Complex Building Operations		Operating expenses		1,738		(266,499)
Mar-21	BO153	Highbury Hall Building Operations		Operating expenses		2,712		(263,786)
Mar-21	BM152	John Higgins Community Complex Building Maintenance		Operating expenses			(4,743)	(268,530)
Mar-21	BM153	Highbury Hall Building Maintenance		Operating expenses			(3,670)	(272,199)
Mar-21	BM154	Nomans Lake Hall Building Maintenance		Operating expenses			(1,470)	(273,669)
Mar-21	W050	Nrlc Grounds Maintenance		Operating expenses			(1,424)	(275,093)
Mar-21	BC179	Netball Court Resurfacing		Capital Expenditure			(68,600)	(343,693)
Mar-21	IO160	Nrlc Infrastructure Other (Capital)		Capital Expenditure			(1,950)	(345,643)
Mar-21	IO161	Nrlc - Infrastructure Other (Capital - Outside)		Capital Expenditure		32,398		(313,245)
Mar-21	IO162	Nrlc - Infrastructure Other (Capital - Inside)		Capital Expenditure		14,000		(299,245)
Mar-21	3110230	NRLC - Contributions & Donations		Capital Income		45,734		(253,511)
Mar-21	W061	Lions Park Maintenance/Operations		Operating expenses			(2,278)	(255,789)
Mar-21	W086	Bmx Track		Operating expenses		2,000		(253,789)
Mar-21	W120	Narrogin Racecourse Track Mtce		Operating expenses			(24,138)	(277,927)
Mar-21	2110312	REC - Insurance Premiums		Operating expenses			(3,025)	(280,952)
Mar-21	BO172	Clayton Road Oval Buildings Operations		Operating expenses		3,798		(277,154)
Mar-21	3110305	REC - Reimbursements - Other Recreation		Operating Revenue		15,500		(261,654)
Mar-21	3110306	REC - Grants - Other Recreation		Operating Revenue		4,500		(257,154)
Mar-21	3110307	REC - Contributions & Donations		Operating Revenue		28,762		(228,392)
Mar-21	IO176	Highbury Tennis Club Equipment		Capital Expenditure			(6,500)	(234,892)
Mar-21	IO018	Railway Dam		Capital Expenditure		8,000		(226,892)
Mar-21	3110306	REC - Grants - Other Recreation		Capital Income			(4,500)	(231,392)
Mar-21	3110307	REC - Contributions & Donations		Capital Income			(50,000)	(281,392)
Mar-21	5110254	REC - Other Income Contributions Reimb (Capital) GEN		Operating Revenue		16,600		(264,792)
Mar-21	2110512	LIB - Office Equipment Maintenance		Operating expenses		3,500		(261,292)
Mar-21	2110514	LIB - Subscriptions & Memberships		Operating expenses		4,600		(256,692)

Date	GL / Job Number	Description	Council Resolution	Classification	Non Cash Adjustment	Increase in Available Cash	Decrease in Available Cash	Amended Budget Running Balance
Mar-21	BO190	Library Building Operations		Operating expenses		4,800		(251,892)
Mar-21	BM190	Library Building Maintenance		Operating expenses		11,100		(240,792)
Mar-21	FE033	Lib - F&E Minor Assets		Capital Expenditure		19,000		(221,792)
Mar-21	5110553	LIB - Capital Grants		Capital Income			(15,000)	(236,792)
Mar-21	BO201	Museum Building Operations		Operating expenses		1,202		(235,590)
Mar-21	5110660	HERITAGE GRANTS		Capital Income			(13,815)	(249,405)
Mar-21	2110801	OTHCUL - Australia Day		Operating expenses			(19,790)	(269,195)
Mar-21	2110815	OTHCUL - Rev Heads		Operating expenses			(4,650)	(273,845)
Mar-21	2110831	OTHCUL - Other Expenditure		Operating expenses		12,000		(261,845)
Mar-21	3110802	OTHCUL - Grants - Other Culture		Operating Revenue		26,775		(235,070)
Mar-21	IO101	Gnarojin Community Garden Projects		Capital Expenditure			(3,000)	(238,070)
Mar-21	IR002	Earl Street - Renewal (Local)		Capital Expenditure		13,400		(224,670)
Mar-21	IR209	Dongolocking Road - Upgrade (Rural)		Capital Expenditure			(16,000)	(240,670)
Mar-21	IRTREE	Street Tree Capital		Capital Expenditure			(7,554)	(248,224)
Mar-21	IF038	Argus Street Footpath Construction		Capital Expenditure		17,232		(230,992)
Mar-21	IF052	Park Street Footpath Construction		Capital Expenditure		6,549		(224,443)
Mar-21	IB002	Manaring Bridge (R2R) (Capital)		Capital Expenditure		270,000		45,557
Mar-21	3120101	ROADC - Roads to Recovery Grant		Capital Income			(270,000)	(224,443)
Mar-21	DM117	Drainage Maintenance Cooraming Road		Operating expenses			(2,500)	(226,943)
Mar-21	DM212	Drainage Maintenance Narrogin Valley Road		Operating expenses			(5,000)	(231,943)
Mar-21	DM216	Drainage Maintenance Highbury West Road		Operating expenses			(5,400)	(237,343)
Mar-21	DM217	Roadm - Mackenzie		Operating expenses			(3,800)	(241,143)
Mar-21	DMGEN	Drainage Maintenance General		Operating expenses		68,461		(172,682)
Mar-21	KERB	Kerb Maintenance		Operating expenses		16,798		(155,884)
Mar-21	SIGNS	Signs & Traffic Control Expenses		Operating expenses		16,577		(139,307)
Mar-21	2120208	ROADM - Street Lighting Maintenance/Operations		Operating expenses		10,000		(129,307)
Mar-21	3120500	LICENSING - Transport Licensing Commission		Operating Revenue		5,000		(124,307)
Mar-21	2130199	RURAL - Administration Allocated		Operating expenses			(15,386)	(139,693)
Mar-21	BO257	Building Operations Shop 2 39-45 Federal St Narrogin		Operating expenses			(2,000)	(141,693)
Mar-21	BM257	Building Maintenance Shop 2 39-45 Federal St Narrogin		Operating expenses			(2,000)	(143,693)
Mar-21	2130207	TOUR - Visitor Information Bay Williams Road / RV Bays Maintenance		Operating expenses		5,000		(138,693)
Mar-21	3130200	TOUR - Caravan Park Fees		Operating Revenue		30,000		(108,693)
Mar-21	3130205	TOUR - Managers Rental Reimbursements (Exc GST)		Operating Revenue			(6,000)	(114,693)
Mar-21	2130319	BUILD - Contract Building Surveyor		Operating expenses		19,000		(95,693)
Mar-21	3130300	BUILD - Building License Fees		Operating Revenue		4,000		(91,693)
Mar-21	3130303	BUILD - Building Officer Regional Support Income		Operating Revenue			(5,000)	(96,693)
Mar-21	3130501	ECONOM DEV - recoup of unutilised \$Narrogin vouchers		Operating Revenue		36,409		(60,284)
Mar-21	BM255	Cafe 45 Federal St Building Maintenance		Operating expenses			(13,300)	(73,584)
Mar-21	2130616	ECONOM - Intra Town Bus Service		Operating expenses		10,000		(63,584)
Mar-21	3130600	ECONOM - Commercial Property Lease income		Operating Revenue			(5,000)	(68,584)
Mar-21	BC290	30 Gray St Building Upgrade		Capital Expenditure			(15,000)	(83,584)
Mar-21	PW999	Private Works - Budget Purposes Only		Operating expenses		12,000		(71,584)
Mar-21	PWGEN	Private Works Small Jobs		Operating expenses			(40,000)	(111,584)
Mar-21	3140100	PRIVATE - Private Works Income		Operating Revenue		33,202		(78,382)
Mar-21	2140215	PWO - WORKS - Wages Administration Hours		Operating expenses			(89,091)	(167,473)
Mar-21	2140217	PWO - WORKS - Sick Pay		Operating expenses			(10,339)	(177,812)
Mar-21	2140218	PWO - WORKS - Annual Leave		Operating expenses			(6,862)	(184,674)
Mar-21	2140227	PWO - WORKS - Protective Clothing		Operating expenses		14,500		(170,174)
Mar-21	2140293	PWO - Less - Allocated to Works (PWO's)		Operating expenses		102,042		(68,132)
Mar-21	2140302	POC - Fuels and Oils		Operating expenses		32,093		(36,039)

Date	GL / Job Number	Description	Council Resolution	Classification	Non Cash Adjustment	Increase in Available Cash	Decrease in Available Cash	Amended Budget Running Balance
Mar-21	2140307	POC - Insurance		Operating expenses			(1,742)	(37,781)
Mar-21	2140394	POC - LESS Plant Operation Costs Allocated to Works		Operating expenses		2,033		(35,748)
Mar-21	3140301	POC - Reimbursements (Ex GST)		Operating Revenue			(8,000)	(43,748)
Mar-21	2140500	ADMIN - Salaries & Wages		Operating expenses		20,219		(23,529)
Mar-21	2140501	ADMIN - Superannuation		Operating expenses			(8,067)	(31,596)
Mar-21	2140504	ADMIN - Training & Development		Operating expenses		2,000		(29,596)
Mar-21	2140507	ADMIN - Travel & Accommodation		Operating expenses			(2,000)	(31,596)
Mar-21	2140528	ADMIN - Consultants		Operating expenses			(40,000)	(71,596)
Mar-21	2140599	ADMIN - Administration Overheads Recovered		Operating expenses		50,000		(21,596)
Mar-21	3140502	ADMIN - LGIS Good Claims Rebate		Operating Revenue		9,276		(12,320)
Mar-21	3140505	ADMIN - Reimbursements		Operating Revenue			(5,680)	(18,000)
Mar-21	BC260	Admin Office Building Capital		Capital Expenditure			(12,000)	(30,000)
Mar-21	PA005H	0Ngn Emccs Vehicle 2019(2)		Capital Expenditure		43,000		13,000
Mar-21	PA047E	002 Ngn Mf Vehicle 2020		Capital Expenditure		30,000		43,000
Mar-21	PD005G	Proceeds On Disposal - Emccs Vehicle 2019(1)		Capital Income			(15,000)	28,000
Mar-21	PD047E	Proceeds Of Disposal - 002 Ngn Mf Vehicle		Capital Income			(15,000)	13,000
Mar-21	5140560	ADMIN - Transfers From Reserve		Capital Income			(43,000)	(30,000)
Mar-21	2140600	COMMUNITY - Salaries & Wages		Operating expenses		38,851		8,851
Mar-21	2140699	Community Services Overheads Recovered		Operating expenses			(38,851)	(30,000)
Mar-21	PA004D	Ngn 0 Mic Vehicle 2018		Capital Expenditure		30,000		0
Apr-21	2110265	NRLC- Contract Management Expense GEN		Operating expenses			(76,000)	0
Apr-21	4110270	NRLC-Transfers to Reserve		Capital Expenditure		76,000		0
					-	4,705,424	-4,705,424	0

10.3.3 PROPOSED 2021/22 FEES AND CHARGES

File Reference	12.4.1
Disclosure of Interest	Neither the Author nor Authorising Officer have any Impartiality, Financial or Proximity Interests that requires disclosure.
Applicant	Shire of Narrogin
Previous Item Numbers	Nil
Date	10 June 2021
Author	Manisha Barthakur – Senior Finance Officer – Strategic
Authorising Officer	Frank Ludovico – Executive Manager Corporate and Community Services
Attachments	1. Proposed 2021/22 Fees and Charges

Summary

The Shire's proposed Fees and Charges are presented to Council for consideration for the Financial Year 2021/22. The approved Fees and Charges are required to be advertised for a minimum period of seven (7) days before the new fees and charges become effective early in the start of the 2021/22 financial year (approximately 16 July 2021)

The Fees and Charges proposed, in some cases, reflect a two- year increase because Fees and Charges were not increased in 2020/21 due to the COVID19 pandemic.

Background

The proposed Fees and Charges have been collated and compiled in consultation with Executive Management responsible for providing the relevant services to the community and ensuring appropriate levels of income/cost recovery is generated for the Shire.

Attached is a Schedule of the proposed Fees and Charges for 2021/22. The 2020/21 Fees and Charges have been included for Council's reference along with percentage change for each fee.

Consultation

- Chief Executive Officer
- Executive Manager Corporate and Community Services
- Executive Manager Development and Regulatory Services
- Executive Manager Technical and Rural Services
- Manager Corporate Services
- Manager Operations
- Manager Community Care Services
- Manager Library Services
- Manager Community Leisure and Culture.

Statutory Environment

Local Government Act 1995, Section 6.16 (Imposition of fees and charges), 6.17 (Setting level of fees and charges) and 6.19 (Local government to give notice of fees and charges). Local Government Act 1995, Section 1.7 (Local public notice).

Regulation 3A Local Government (Administration) Regulations 1996 prescribes how Local Public Notice may be given. They are:

- published on the local government's official website; and any three of the following
- publication in a newspaper circulating generally in the State;
- publication in a newspaper circulating generally in the district;
- publication in 1 or more newsletters circulating generally in the district;
- publication on the official website of the Department or another State agency, as appropriate having regard to the nature of the matter and the persons likely to be affected by it;
- circulation by the local government by email, text message or similar electronic means, as appropriate having regard to the nature of the matter and the persons likely to be affected by it;
- exhibition on a notice board at the local government offices and each local government library in the district;
- posting on a social media account administered by the local government, for a period specified in the Local Government Act 1995, or if no period specified, for a period not less than 7 days.

Policy Implications

Nil

Financial Implications

The revenue raised from fees and charges set by Council will underpin to a degree, its ability to provide services and facilities for the 2020/21 financial year and into the future.

Strategic Implications

Shire of Narrogin Strategic Community Plan 2017-2027		
Objective	4.	Civic Leadership Objective (Continually enhance the Shire's organisational capacity to service the needs of a growing community)
Outcome:	4.1	An efficient and effective organisation

Comment/Conclusion

Overall, Fees and Charges have increased by only 2% and reflect a two-year increase because Fees and Charges were not increased in 2020/21 due to the COVID19 pandemic.

In some instances, new fees were created to reflect new activities and in other areas greater clarification of a fee has been provided (eg the legal authority to raise the fee). Generally, the changes are considered relatively minor.

In respect to Refuse Charges, fees were again assessed to consider whether or not they reflected the true Shire expenditure associated with this service. The nil increase in 2020/21 affected this model and

cost increases over two years have flown into this calculation. In 2021/22 it is proposed, for the general householder, the fees will increase from \$310pa to \$322pa, a \$12 increase.

A complete list of fees and charges (including statutory) have been included in the schedule to provide users with a single point of reference for fees and charges. Please note that Statutory Fees and Charges can be altered at any time by relevant Government Departments, and if this occurs, the Schedule will be updated.

Voting Requirements

Absolute Majority

OFFICERS' RECOMMENDATION

That Council adopt the 2021/22 Fees and Charges as presented in Attachment 1 and advertise for information for a period of 7 days prior to them taking affect through the following means:

- published on the official website of the Shire of Narrogin;
- publication in the Narrogin Observer;
- exhibition on a notice board at the Shire and Library; and
- posting on the Shire's Facebook page.

Schedule of Fees and Charges 2021/22

30/06/2021

GL CODE	DESCRIPTION	GST (inc)	Statutory fee "S"	2020/21	Legislative Authority	Proposed 2021/22	Comment	%increase 20/21 to 21/22	2020/21 YTD Income
				\$					
BUSINESS UNIT: GENERAL PURPOSE FUNDING									
Rates									
3030125.1502	Penalty interest			8.00%	\$6.51 LGA	7.00%		(13%)	42,295.71
3030125.1502	Penalty Interest for those rate payment who have Financial Hardship as per the FINANCIAL HARDSHIP Policy			0.00%	Policy 3.12	0.00%		-	-
3030128.1304	Instalment Interest			5.50%	\$6.45 LGA	5.50%		-	-
3030128.1304	Instalment charge (statutory 4 instalments)			52.50	\$6.45 LGA	52.50		-	-
3030128.1304	Instalment charge (statutory 4 instalments) for those rate payment who have Financial Hardship as per the FINANCIAL HARDSHIP Policy			0.00	Policy 3.12	0.00		-	45,286.37
Ad hoc payment arrangements									
3030132.1304	1 to 2 payments			0.00	\$6.16 LGA	0.00		-	-
3030132.1304	2 to 5 payments			18.50	\$6.16 LGA	18.70		1%	-
3030132.1304	Greater than 5			52.50	\$6.16 LGA	53.00		1%	-
3030132.1304	Payment arrangement - dishonour fee			11.00	\$6.16 LGA	11.10		1%	-
3040204.1304	Electoral roll copy			15.30	\$6.16 LGA	15.30		-	-
3040204.1304	Rate Book (Paper copy)	Yes		102.00	\$6.16 LGA	102.00		-	-
3040204.1304	Rate Book (Electronic copy)	Yes		76.50	\$6.16 LGA	76.50		-	-
3030129.1304	Rate enquiries			76.50	\$6.16 LGA	76.50		-	10,084.12
3100605.1304	Orders & Requisitions			137.70	\$6.16 LGA	137.70		-	19,673.60
3030129.1304	Request for additional copies of a Rate Notice			15.30	\$6.16 LGA	15.30		-	-
3030131.1103	Debt collection fee - Landgate title search fee (per search)			At Cost	\$6.16 LGA	At Cost		-	84,981.33
3030131.1103	Debt collection fee - caveat withdrawal			At Cost	\$6.16 LGA	At Cost		-	-
3030131.1103	Debt collection fee - caveat lodgement			At Cost	\$6.16 LGA	At Cost		-	-
3030131.1103	Debt collection fee - property seize & sale order			At Cost	\$6.16 LGA	At Cost		-	-
Other General Purpose Funding									
	Outstanding sundry debtors			5.50%	\$6.13 LGA	7.00%		27%	-
	Interest for outstanding sundry debtors who have Financial Hardship as per the FINANCIAL HARDSHIP Policy			0.00%	Policy 3.12	0.00%		-	-
3030404.1304	1 to 2 payments			0.00	\$6.16 LGA	0.00		-	-
3030404.1304	3 to 5 payments			18.50	\$6.16 LGA	18.70		1%	-
3030404.1304	Greater than 5			52.50	\$6.16 LGA	53.00		1%	-
3030404.1304	Payment arrangement - dishonour fee			11.00	\$6.16 LGA	11.10		1%	-
Office of CEO									
	Giant Dominos (Per Day)	Yes		50.00	\$6.16 LGA	50.00		-	-
	Giant Checkers (Per Day)	Yes		50.00	\$6.16 LGA	50.00		-	-
	Giant Pick Up Sticks (Per Day)	Yes		50.00	\$6.16 LGA	50.00		-	-
	Giant Yahtzee (Per Day)	Yes		50.00	\$6.16 LGA	50.00		-	-
	Giants Os & Xs (Per Day)	Yes		50.00	\$6.16 LGA	50.00		-	-
	Giant Jenga (Per Day)	Yes		50.00	\$6.16 LGA	50.00		-	-
	Bocce (Per Day)	Yes		50.00	\$6.16 LGA	50.00		-	-

Schedule of Fees and Charges 2021/22

30/06/2021

GL CODE	DESCRIPTION	GST (inc)	Statutory fee "S"	2020/21	Legislative Authority	Proposed 2021/22	Comment	%increase 20/21 to 21/22	2020/21 YTD Income
BUSINESS UNIT: LAW, ORDER & PUBLIC SAFETY									
Ranger Services									
3050302.1301	Seizure impoundment registered dog/cat		S	30	S6.16 LGA	30.00		-	
3050302.1301	Seizure impoundment unregistered dog/cat		S	100	S6.16 LGA	100.00		-	2,750.40
3050300.1304	Daily impound fee			16.00	S6.16 LGA	16.00		-	
3050303.1304	Destruction/disposal of dog/cat			160.00	S6.16 LGA	160.00		-	
3050300.1304	Surrender of dog/cat			50.00	S6.16 LGA	50.00		-	
3050300.1304	Out of hours release fee		S	100.00	S6.16 LGA	100.00		-	
3050300.1304	Sale of dog/cat (excluding license)	Yes		53.00	S6.16 LGA	53.00		-	1,964.18
3050301.1304	Unsterilised dog registration fee 1 year		S	50.00	R17 DR	50.00		-	
3050301.1304	Unsterilised dog registration pensioner fee 1 year		S	25.00	R17 DR	25.00		-	
3050301.1304	Unsterilised dog registration fee 3 years		S	120.00	R17 DR	120.00		-	
3050301.1304	Unsterilised dog registration pensioner fee 3 years		S	60.00	R17 DR	60.00		-	
3050301.1304	Unsterilised dog registration fee life time		S	250.00	R17 DR	250.00		-	
3050301.1304	Unsterilised dog registration pensioner fee life time		S	125.00	R17 DR	125.00		-	
3050301.1304	Sterilised dog/cat registration fee 1 year		S	20.00	R17 DR & Sch 3 CR	20.00		-	
3050301.1304	Sterilised dog/cat registration pensioner fee 1 year		S	10.00	R17 DR & Sch 3 CR	10.00		-	
3050301.1304	Sterilised dog/cat registration fee 3 years		S	42.50	R17 DR & Sch 3 CR	42.50		-	
3050301.1304	Sterilised dog/cat registration pensioner fee 3 years		S	21.25	R17 DR & Sch 3 CR	21.25		-	
3050301.1304	Sterilised dog/cat registration fee life time		S	100.00	R17 DR & Sch 3 CR	100.00		-	
3050301.1304	Sterilised dog/cat registration pensioner fee life time		S	50.00	R17 DR & Sch 3 CR	50.00		-	
3050301.1304	Sterilised Working dog fee 1 year		S	5.00	R17 DR	5.00		-	
3050301.1304	Sterilised Working dog fee 3 year		S	10.60	R17 DR	10.60		-	
3050301.1304	Sterilised Working dog fee lifetime		S	25.00	R17 DR	25.00		-	
3050301.1304	Dangerous dog registration fee 1 year		S	50.00	R17 DR	50.00		-	
3050301.1304	Annual application for approval or renewal of approval to breed cats (per cat)		S	100.00	Sch 3 CR	100.00		-	12,160.71
3050305.1304	Application to keep more than standard number of cats - residential		S	20.00	S6.16 LGA	20.00		-	
3050305.1304	Application to keep more than standard number of cats - cat management facility		S	500.00	S6.16 LGA	500.00		-	
3050305.1304	Renewal of permit - cat management facility or cat breeder		S	100.00	S6.16 LGA	100.00		-	
3050301.1304	Cats registered after 31 May in any year, for that registration year		S	50% of the fee payable	Sch 3 CR	50% of the fee payable		-	
3050305.1304	Application for a kennel licence		S	700.00	R17 DR	700.00		-	
3050305.1304	Issue of a kennel licence or renewal of a kennel licence		S	100.00	S6.16 LGA	100.00		-	
3050305.1304	Application to transfer a kennel licence		S	100.00	S6.16 LGA	100.00		-	
3050305.1304	Application to keep more than standard number of dogs		S	50.00	S6.16 LGA	50.00		-	
3050305.1304	Microchipping of impounded animal			30.00	R30A DR	30.00		-	480.89
3050305.1304	Impoundment of shopping trolley (per trolley)			25.00	S6.16 LGA	25.00		-	
3050301.1304	Dogs kept in approved kennel establishment licensed under section 27 of the Act, where not otherwise registered (per establishment)		S	200.00	S27 DA	200.00		-	
3050301.1304	Penalties - Dog Act 1976		S	200.00	R33 DR	200.00	Penalties too numerous to list. Only reference to legislation.	-	
3050301.1304	Penalties - Cat Act 2011		S	200.00	Sch 3 CR	200.00	Penalties too numerous to list. Only reference to legislation.	-	
3050301.1304	Penalty: dog not on leash in certain public places		S	200.00		200.00		-	
3050301.1304	Penalty: dog causing a nuisance		S	200.00		200.00		-	
3050301.1304	Penalty: failure of alleged offender to give full name and address		S	200.00		200.00		-	
3050304.1304	Ranger hourly rate (including travel time)	Yes		84.00	S6.16 LGA	84.00		-	11,213.21
3050304.1304	Mileage rate per km	Yes		1.50	S6.16 LGA	1.50		-	

Schedule of Fees and Charges 2021/22

GL CODE	DESCRIPTION	GST (inc)	Statutory fee "S"	2020/21	Legislative Authority	Proposed 2021/22	Comment	%increase 20/21 to 21/22	2020/21 YTD Income
3050305.1304	Removal of trapped animal	Yes		21.00	\$6.16 LGA	21.00		-	
3050305.1304	Hire of small animal trap per week	Yes		21.00	\$6.16 LGA	21.00		-	
3050305.1304	Hire of large animal trap per week	Yes		32.00	\$6.16 LGA	32.00		-	
	Bond for animal trap			58.00	\$6.16 LGA	58.00		-	
3050305.1304	Anti barking device per month	Yes		32.00	\$6.16 LGA	32.00		-	
	Anti barking device bond			58.00	\$6.16 LGA	58.00		-	
	Dangerous dog collar:							-	
3050305.1304	- Small	Yes		35.00	\$6.16 LGA	35.00		-	
3050305.1304	- Medium	Yes		55.00	\$6.16 LGA	55.00		-	
3050305.1304	Dangerous dog sign	Yes		32.00	\$6.16 LGA	32.00		-	
	Abandoned / Impounded Vehicles							-	
3050400.1301	- Towing charge			Cost plus 20%	\$6.16 LGA	Cost plus 20%		-	377.53
3050400.1301	- Storage of impounded vehicle (per month or part thereof)			70.00	\$6.16 LGA	70.00		-	
3050400.1301	- Administration			35.00	\$6.16 LGA	35.00		-	
	Stock Impoundment							-	
3050400.1301	- As per Section 464 Local Government (Miscellaneous Provisions) Act 1960		S	As per Act	S464 LG(MP)A	As per Act		-	
BUSINESS UNIT: HEALTH									
Health Services									
3070300.1300	Application to install waste water treatment system		S	118.00	R4 HTS	118.00		-	1,141.33
3070300.1300	Permit to use waste water treatment system		S	118.00	R4 HTS	118.00		-	
	Inspection fee of Waste Water treatment System	Yes		125.00	\$6.16 LGA	125.00		-	
3070300.1300	Local Government Report Fee	Yes		125.00	R4A HTS	125.00		-	
3070300.1300	Annual itinerant food vendor/stallholder fee new or renewal (pro rata applies)		S	250.00	S140 FA	350.00		40%	
3070300.1300	Itinerant food vendor/stallholder fee per day		S	50.00	S140 FA	50.00		-	
3070300.1300	Temporary Food Stall – Community group/organisation		S	0.00	S140 FA	0.00		-	
3070301.1304	Annual food business (including Schools) registration fee (pro rata applies)		S	110.00	S140 FA	115.00		5%	3,630.00
3070300.1300	Food business notification fee			50.00	S140 FA	50.00		-	
3070301.1304	Food business follow up inspection		S	110.00	S140 FA	115.00		5%	
3070300.1300	Public Building Inspection fee (commercial)		S	60.00	\$6.16 LGA	65.00		8%	
3070300.1300	Public Building Inspection fee (not for profit)		S	0.00	\$6.16 LGA	0.00		-	
3070300.1300	Annual caravan park licence		S	220.00	\$6.16 LGA	225.00		2%	
3070301.1304	Senior EHO - per hour	Yes		85.00	\$6.16 LGA	85.00		-	
3070301.1304	EHO - per hour	Yes		60.00	\$6.16 LGA	60.00		-	
3070301.1304	Mileage rate per km	Yes		1.50	\$6.16 LGA	1.50		-	
3070301.1304	Liquor Act Certification Section 39 (commercial)			122.00	\$6.16 LGA	125.00		2%	
3070301.1304	Liquor Act Certification Section 39 (not for profit)			61.00	\$6.16 LGA	61.00		-	
3070301.1304	Meat inspection fee			EHO Charge Out Rate	\$6.16 LGA	EHO Charge Out Rate		-	
3070301.1304	Settlement inspection fee - upon request			110.00	\$6.16 LGA	115.00		5%	
3070301.1304	Re-inspection fee		S	110.00	\$6.16 LGA	115.00		5%	

Schedule of Fees and Charges 2021/22

GL CODE	DESCRIPTION	GST (inc)	Statutory fee "S"	2020/21	Legislative Authority	Proposed 2021/22	Comment	%increase 20/21 to 21/22	2020/21 YTD Income
BUSINESS UNIT: EDUCATION & WELFARE									
Homecare									
	HACC as set by Department of Health and Ageing schedule of fees and charges		S						-
	COMMONWEALTH HOME CARE PACKAGES (CHCP)								-
	Admin fee (client cost)			20%	S3.3 ACA	25%	Increased due to rising costs of care required	25%	-
	Co-ordination fee			5%	S3.3 ACA	10%	Increased due to rising costs of care required	100%	-
	- Contingency internal			5%	S3.3 ACA	10%	Increased due to rising costs of care required	100%	-
	- Contingency external			10%	S3.3 ACA	15%	Increased due to rising costs of care required	50%	-
	Support worker (week day) per hour (include Personal Care and Home Maintenance)			60.50	S3.3 ACA	70.00	Increased due to rising costs of care required	16%	-
	Support worker (week day after 6pm) per hour (include Personal Care and Home Maintenance)			71.50	S3.3 ACA	80.00	Increased due to rising costs of care required	12%	-
	Support worker (Saturday)			71.50	S3.3 ACA	105.00	Increased due to rising costs of care required	47%	-
	Support worker (Sunday) per hour			71.50	S3.3 ACA	120.00	Increased due to rising costs of care required	68%	-
	Support worker (Public Holiday) per hour			126.50	S3.3 ACA	140.00	Increased due to rising costs of care required	11%	-
	Social Support Group Weekdays (per day)			112.20	S3.3 ACA	135.00	Increased due to rising costs of care required	20%	-
	Social Support Group (Saturday) per day			134.20	S3.3 ACA	0.00	Does not operate on weekends	(100%)	-
	Social Support Group (Sunday and Public Holidays) per day			167.20	S3.3 ACA	0.00	Does not operate on weekends	(100%)	-
	Social Support Group transport 0 - 10km per trip (Driver Included) (Base Rate)			22.00	S3.3 ACA	35.20	Increased due to rising costs of care required	60%	-
	Social Support Group Transport per trip 11 - 20 kms Driver Included				S3.3 ACA	52.80	NEW	-	-
	Social Support Group Transport per trip 21- 40kms Driver Included				S3.3 ACA	70.40	NEW	-	-
	Travel per service over 40 kms per km:				S3.3 ACA	1.20 per km	NEW	-	-
	Note: the applicable Support Worker Charge will also be incurred.							-	-
	Meals provided per meal - delivered by Meals on Wheels Committee main meal			Set by WACHS	S3.3 ACA	Set by WACHS		-	-
	Meals provided per meal - delivered by Meals on Wheels Committee main meal and dessert			Set by WACHS	S3.3 ACA	Set by WACHS		-	-
	Meals delivered by NHC			22.00	S3.3 ACA	30.00		36%	-
	Meals delivered by NHC - Sunday / Public Holiday			27.50	S3.3 ACA	30.00		9%	-
	Entry Fee			250.00	S3.3 ACA	250.00		-	-
	Exit Fee			250.00	S3.3 ACA	250.00		-	-
	Co-ordination								
	Co-ordination - An additional hourly rate may be applied in exceptional circumstance where high levels of Case Management are required.			60.50	S3.3 ACA	120.00		98%	-
	Travel per service per one way 0 - 10kms (Driver included) (Base Rate)			35.20	S3.3 ACA	35.20		-	-
	Transport per service, one way 11 - 20 kms Driver Included				S3.3 ACA	52.80	NEW	-	-
	transport per service, one way 21-40 kms Driver included				S3.3 ACA	70.40	NEW	-	-
	Travel per service over 40 kms per km.			\$0.94 per km	S3.3 ACA	1.20 per km		28%	-
	Note: the applicable Support Worker Charge will also be incurred.							-	-
	Acquired on behalf of the Client							-	-
	Webster Packing and other consumables			At cost				-	-

Schedule of Fees and Charges 2021/22

GL CODE	DESCRIPTION	GST (inc)	Statutory fee "S"	2020/21	Legislative Authority	Proposed 2021/22	Comment	%increase 20/21 to 21/22	2020/21 YTD Income
	Products acquired on behalf of the client (not related to equipment)				S3.3 ACA	Cost plus 10% to cover postage, staff time		10%	
	Wound care products				S3.3 ACA	Cost plus 10% to cover postage, staff time		10%	
	Clinical Nursing Care			At cost	S3.3 ACA	125.00		-	
	Allied Health			At cost	S3.3 ACA			-	
	Other Charges such as Equipment			At cost	S3.3 ACA	Cost plus 10%		10%	
	Mileage – charge out when Officers use their own vehicle to attend clients-			\$0.94 per km			Delete	-	
	Flexible Respite or Cottage respite (weekdays)			800.00	S3.3 ACA	1,085.00	This is same as given by CHSP funding, includes cost of meals	36%	
	Flexible Respite or Cottage respite (weekends and public holidays)			800.00	S3.3 ACA	1,285.00	This is same as given by CHSP funding, includes cost of meals	61%	
	Our core service hours are 7 am to 6 pm. A minimum service duration of 2 hour will apply outside these hours. This may be reduced if another client needs a service around the same time.				S3.3 ACA		increased to two hours	-	
	Late Notice Cancellation Charges- Where a service is cancelled with less than 24 hours' notice a charge equivalent to the hourly charge will apply.				S3.3 ACA			-	
								-	
								-	
	COMMONWEALTH HOME SUPPORT PROGRAM (CHSP)							-	
	Commonwealth funded Flexible Respite Fees – per 24 hour period				S3.3 ACA	995.00			
	<i>Includes Eligible Home Care Package Clients</i>							-	
	Respite Care Fee (per 24 hour period)			68.00	S3.3 ACA	90.00		32%	
	Breakfast			5.00		0.00		(100%)	
	Lunch			8.00		0.00		(100%)	
	Dinner			9.00		0.00		(100%)	
								-	
	HOME CARE PACKAGES (HCP)						Delete Program has ceased	-	
	Respite Care Fee (per 24 hour period)			800.00			Delete Program has ceased	(100%)	
	Breakfast			5.00			Delete Program has ceased	(100%)	
	Lunch			8.00			Delete Program has ceased	(100%)	
	Dinner			9.00			Delete Program has ceased	(100%)	
	PLEASE NOTE: If the Home Care Package does not have enough surplus funds to cover the daily cost, then CHSP Flexible respite funding can be applied for and the cost is \$68.00 plus \$22.00 for meals.						Delete Program has ceased	-	
								-	
	Domestic Assistance, Personal Care, Home Maintenance, Social Support Individual			10.00	S3.3 ACA	10.00	Ex HACC	-	
	Nursing Care - per hour			10.00	S3.3 ACA	10.00	Ex HACC	-	
	Social Support Group			10.00	S3.3 ACA	10.00	Ex HACC	-	
	Social Support Group Meal			8.00	S3.3 ACA	8.00	Ex HACC	-	
	Social Support Group Transport (each way)			2.50	S3.3 ACA	3.00	Ex HACC	20%	
	Transport - individual (each way)			5.00	S3.3 ACA	4.00	Ex HACC	(20%)	
	Transport - shoppers bus			2.50	S3.3 ACA	5.00	Ex HACC	100%	
	Monthly Excursion			15.00	S3.3 ACA	15.00	Ex HACC	-	
	Overnight excursions				S3.3 ACA	at cost	cost depends on accommodation, meals etc. Each trip is budgeted individually	-	
								-	

Schedule of Fees and Charges 2021/22

GL CODE	DESCRIPTION	GST (inc)	Statutory fee "S"	2020/21	Legislative Authority	Proposed 2021/22	Comment	%increase 20/21 to 21/22	2020/21 YTD Income
General Fees									
	Brokerage (Up to) per hour	Yes		101.00	S3.3 ACA	120.00		19%	-
	Rosa bus hire per hour (No dry hire)	Yes		60.50	S3.3 ACA	120.00		98%	-
	Rosa bus driver rate per km	Yes		1.10	S3.3 ACA	1.20		9%	-
	Hire of Jesse House (as approved by Manager)	Yes		150.00	S3.3 ACA	150.00		-	-
	Nursing Care – Per Hour (Wound care & other products extra cost)			10.00			Delete	(100%)	-
	The Gadabout Club – Lunch at own cost			15.00			Now monthly excursion	(100%)	-
	Busy-Bee Craft Group			5.00			Now monthly excursion	(100%)	-
	Walk, Talk and Exercise (Includes Transport)			8.00			Now monthly excursion	(100%)	-
	Men's Shed (Includes Transport)			8.00			Now monthly excursion	(100%)	-
	Shopping Bus (transport to and from CBD) each way			2.00			Delete	(100%)	-
	Transport (including volunteer transport) one way			5.00			Delete	(100%)	-
Other Welfare									
	Veterans as set by the Department of Veterans Affairs	Yes						-	-
	CATS vehicle							-	-
	Perth	Yes		75.00	S6.16 LGA	75.00		-	-
	Busselton	Yes		85.00	S6.16 LGA	85.00		-	-
BUSINESS UNIT: STAFF HOUSING									
Staff Housing									
	Staff will be charged the difference between the housing subsidy and the cost to the Shire of renting the residential building (unless the employment contract states otherwise).	Yes			S6.16 LGA	Yes		-	-

Schedule of Fees and Charges 2021/22

GL CODE	DESCRIPTION	GST (inc)	Statutory fee "S"	2020/21	Legislative Authority	Proposed 2021/22	Comment	%increase 20/21 to 21/22	2020/21 YTD Income
BUSINESS UNIT: COMMUNITY AMENITIES									
Sanitation - Household & Other									
Rubbish Charges									
3100100.1304	Domestic refuse services (first service)			226.00	\$6.16 LGA	234.00		4%	476,822.79
3100200.1304	Commercial refuse services (first service)			231.00	\$6.16 LGA	239.00		3%	43,427.36
3100203.1304	Special refuse service (first service)			339.00	\$6.16 LGA	357.00		5%	37,968.00
3100101.1304	Additional service - household			226.00	\$6.16 LGA	234.00		4%	3,164.00
3100207.1304	Additional service - commercial			253.00	\$6.16 LGA	262.00		4%	24,717.00
3100201.1304	Additional pickup - commercial on a per bin per pick up basis			231.00	\$6.16 LGA	239.00		3%	43,264.38
3100203.1304	Additional service - special refuse service			339.00	\$6.16 LGA	351.00		4%	37,968.00
3100105.1304	Domestic recycling service			84.00	\$6.16 LGA	88.00		5%	171,182.75
Refuse Site Fees									
Free access for rate payers and residents who deliver capacities less than 1m3 to the refuse site, subject to proof of rate payer or residential status in the Shire of Narrogin with proof being demonstrated via an acceptable process such as, Shire of Narrogin registration plates, rate notice or driver's licence									
* NOTE: Quantities are per cubic metre or part thereof									
3100202.1304	Waste per cubic metre			16.00	\$6.16 LGA	16.00		-	-
3100202.1304	Demolition waste per cubic metre			77.00	\$6.16 LGA	77.00		-	-
3100202.1304	Truck bodies (all fluids, tyres and non-metal parts removed)			210.00	\$6.16 LGA	210.00		-	-
3100202.1304	Passenger / Motorcycle tyre			8.25	\$6.16 LGA	8.25		-	-
3100202.1304	Light truck tyre			11.00	\$6.16 LGA	11.00		-	-
3100202.1304	Truck tyre			15.00	\$6.16 LGA	15.00		-	-
3100202.1304	Car/truck battery			3.75	\$6.16 LGA	3.75		-	-
3100202.1304	Car bodies (all fluids, tyres and non-metal parts removed)			39.00	\$6.16 LGA	39.00		-	-
3100202.1304	Small animal carcasses			27.00	\$6.16 LGA	27.00		-	-
3100202.1304	Large animal carcasses			81.00	\$6.16 LGA	81.00		-	-
3100202.1304	Liquid waste (mineral oil) recyclable (not cooking oil) non-commercial dollars per litre.			0.20	\$6.16 LGA	0.20		-	-
3100202.1304	Liquid waste (mineral oil) recyclable (not cooking oil) commercial dollars per litre.			0.20	\$6.16 LGA	0.20		-	-
3100202.1304	Liquid waste (excludes oils) per litre (dollars per litre)			0.10	\$6.16 LGA	0.10		-	-
3100202.1304	Green waste less than 1 cubic metre (MUST BE A RESIDENT OR RATEPAYER)			0.00	\$6.16 LGA	0.00		-	-
3100202.1304	Green waste greater than 1 cubic metre (including commercial)			7.00	\$6.16 LGA	7.00		-	-
3100202.1304	Contaminated/Hazardous waste including asbestos or soil per cubic metre (see *NOTE above)			152.00	\$6.16 LGA	152.00		-	-
3100202.1304	Clinical/soiled waste NOT ACCEPTED			0.00	\$6.16 LGA	0.00		-	-
3100202.1304	Power pole butts per linear metre (inc contaminated timber)			148.00	\$6.16 LGA	148.00		-	74,655.48
General Waste from Outside the Shire of Narrogin									
3100202.1304	General Waste generated outside the Shire of Narrogin (conversion of \$79/m3 to tonne (ie multiply by 3) per tonne - as a deterrent. - Waste from metropolitan areas (ie, Subject to Waste Levy) NOT ACCEPTED.			79/m ³	\$6.16 LGA	79/m ³		-	-
3100202.1304	General waste from the Shire of Cuballing subject to Council consent per tonne			79.00	\$6.16 LGA	82.00		4%	-
Recycled Water									
310300.1304	Sale of recycled water per kilo litre	Yes		1.50				-	-
	Sale of recycled water External Supply up to 30,000kl per annum per kilo litre rate	Yes		1.50	\$6.16 LGA	1.28	New Fee as per TWIS Asset Mgt Plan	(15%)	-
	Sale of recycled water External Supply above 30,000kl per annum per kilo litre rate	Yes		1.50	\$6.16 LGA	1.55	New Fee as per TWIS Asset Mgt Plan	3%	-
	Internal Supply Charge Sale of recycled water per kilo litre	No		1.50	\$6.16 LGA	1.10	New Fee as per TWIS Asset Mgt Plan	(27%)	68,290.47
	Narrogin Racing as per lease agreement	Yes					Agreement ended and moving to new arrangement as per TWIS Asset Mgt Plan	-	-

Schedule of Fees and Charges 2021/22

GL CODE	DESCRIPTION	GST (inc)	Statutory fee "S"	2020/21	Legislative Authority	Proposed 2021/22	Comment	%increase 20/21 to 21/22	2020/21 YTD Income
Town Planning									
Planning Services									
3100600.1304	Home Occupation - initial application fee		S	222.00	Part 7 PDR	222.00		-	-
3100600.1304	Home Occupation - annual renewal fee		S	73.00	Part 7 PDR	73.00		-	-
3100600.1304	Zoning Certificates, Property Settlements & Enquiries (Zoning)		S	73.00	Part 17 PDA	73.00		-	-
3100600.1304	Planning Application fees based on cost of development (as amended)								
3100600.1304	(a) Not more than \$50,000		S	147.00	Part 17 PDA	147.00		-	-
3100600.1304	(b) More than \$50,000 but not more than \$500,000 based on estimated costs		S	0.32%	Part 17 PDA	0.32%		-	-
3100600.1304	(c) More than \$500,000 but not more than \$2.5 million		S	\$1,700.00 plus 0.257% for every \$1 in excess of \$500,000	Part 17 PDA	\$1,700.00 plus 0.257% for every \$1 in excess of \$500,000		-	-
3100600.1304	(d) More than \$2.5 million but not more than \$5 million		S	\$7,161.00 plus 0.206% for every \$1 in excess of \$2.5m	Part 17 PDA	\$7,161.00 plus 0.206% for every \$1 in excess of \$2.5m		-	-
3100600.1304	(e) More than \$5 million but not more than \$21.5 million		S	\$12,633.00 plus 0.123% in excess of every \$1 in excess of \$5 million	Part 17 PDA	\$12,633.00 plus 0.123% in excess of every \$1 in excess of \$5 million		-	-
3100600.1304	(f) More than \$21.5 million		S	34,196.00	Part 17 PDA	34,196.00		-	-
3100600.1304	Subdivision/Strata Clearance fees								
3100600.1304	(a) Not more than 5 lots - per lot		S	73.00	Part 17 PDA	73.00		-	-
3100600.1304	(b) More than 5 lots but not more than 195 lots - per lot over 5		S	35.00	Part 17 PDA	35.00		-	-
3100600.1304	(c) More than 195 Lots		S	7,393.00	Part 17 PDA	7,393.00		-	-
3100600.1304	Change of use fee		S	295.00	Part 17 PDA	295.00		-	-
3100600.1304	Fee for use/development already commenced		S	Development fee plus Twice the schedule fee	Part 17 PDA	Development fee plus Twice the schedule fee		-	-
3100600.1304	Provision of Written Planning Advice	Yes		73.00	\$6.16 LGA	73.00		-	-
3100600.1304	Deemed to comply check – development approval exemption for Single House		S		Part 17 PDA	295.00 new		-	-
3100600.1304	Determining an application to amend or cancel development approval	Yes		295.00	Part 17 PDA	295.00		-	-
3100600.1304	Executive Manager Development & Regulatory Services - per hour	Yes		130.00	\$6.16 LGA	130.00		-	-
3100600.1304	Manager - per hour	Yes		85.00	\$6.16 LGA	85.00		-	-
3100600.1304	Town Planner - per hour	Yes		60.00	\$6.16 LGA	60.00		-	-
3100600.1304	Secretary Administrative Officer - per hour	Yes		45.00	\$6.16 LGA	45.00		-	-
3100600.1304	Vehicles mileage rate	Yes		1.50	\$6.16 LGA	1.50		-	-
Structure Plan and Local Development Plan									
Scheme Amendment									
3100600.1304	- Basic			2,800.00	Part 17 PDA	2,800.00		-	-
3100600.1304	- Standard			4,200.00	Part 17 PDA	4,200.00		-	-
3100600.1304	- Complex			5,500.00	Part 17 PDA	5,500.00		-	-
3100600.1304	Sign Application			147.00	Part 17 PDA	147.00		-	-

Schedule of Fees and Charges 2021/22

GL CODE	DESCRIPTION	GST (inc)	Statutory fee "S"	2020/21	Legislative Authority	Proposed 2021/22	Comment	%increase 20/21 to 21/22	2020/21 YTD Income
3100600.1304	Extractive Industry - new			739.00	Part 17 PDA	739.00		-	
3100600.1304	Extractive Industry - commenced or carried out			1,478.00	Part 17 PDA	1,478.00		-	
3100600.1304	Liquor Act Certification Section 40		S	122.00	S6.16 LGA	122.00		-	14,858.23
3100601.1304	Landgate title search fee (per search)			30.00	S6.16 LGA	30.00		-	
	Public Art Contribution				S6.16 LGA	0.5% of the cost of new Development over \$2 million		-	
3100600.1304	Cost per car parking bay			0.00		9,000.00 new	Maybe superseded by proposed new Reg 77H of the Planning and Development Regulations	-	
Other Community Amenities									
Cemetery									
Single Burial Permits:									
3100800.1304	Application	Yes		50.00	S53 CA	50.00		-	27,509.03
3100800.1304	Grant of Right of Burial - immediate use only	No		250.00	S53 CA	250.00	GST Exempt	-	
3100800.1304	Interment in a grave 2.1 metres deep	Yes		1,500.00	S53 CA	1,500.00		-	
3100800.1304	Re-opening of an ordinary grave for 2nd or 3rd burial	Yes		1,500.00	S53 CA	1,500.00		-	
3100800.1304	Reinstatement, if required	Yes		500.00	S53 CA	500.00		-	
3100800.1304	After hours interment - weekdays	Yes		250.00	S53 CA	250.00		-	
3100800.1304	After hours interment - weekend/public holidays	Yes		500.00	S53 CA	500.00		-	
Exhumation:									
3100800.1304	Exhumation	Yes		2,400.00	S53 CA	2,400.00		-	
3100800.1304	Exhumation reinstatement in existing grave, if required	Yes		500.00	S53 CA	500.00		-	
3100800.1304	Interment in a new grave after exhumation	Yes		1,500.00	S53 CA	1,500.00		-	
Ashes									
3100801.1304	Single interment permit:								
3100801.1304	Application (single funeral permit & permission to place a plaque)	Yes		50.00	S53 CA	50.00		-	
3100801.1304	Grant of Right of Burial - interment of ashes in Niche Wall	No		250.00	S53 CA	250.00	GST Exempt. Description change	-	
3100801.1304	Interment - Niche Wall (temporary blank cover)	Yes		200.00	S53 CA	200.00		-	
3100801.1304	Interment - garden	Yes		200.00	S53 CA	200.00		-	
3100800.1304	Interment - grave	Yes		300.00	S53 CA	300.00		-	
3100800.1304	Interment - scattering	Yes		0.00	S53 CA	0.00		-	
3100800.1304	After hours interment - weekdays	Yes		100.00	S53 CA	100.00		-	
3100800.1304	After hours interment - weekend/public holidays	Yes		200.00	S53 CA	200.00		-	
Other									
3100800.1304	Permission to erect Memorial - grave, garden	Yes		80.00	S53 CA	80.00		-	
3100800.1304	Transfer of Right of Burial/Pre-Need Purchase of Certificate			50.00	S53 CA	50.00		-	
3100800.1304	Issue of a copy of Grant Right of Burial /Pre-Need Purchase of Certificate			50.00	S53 CA	50.00		-	
3100800.1304	Renewal of Grant Right of Burial (further 25 years)				S53 CA	250.00	New Fee	-	
3100800.1304	Pre-need services (Reservation)				S53 CA			-	
3100800.1304	Pre-need purchase of certificate for burial - 25 years			300.00	S53 CA	300.00		-	
3100801.1304	Pre-need Grant of Right of Burial - interment of ashes in Niche Wall			300.00	S53 CA	300.00		-	
3100801.1304	Pre-need of certificate for garden memorial position	Yes		not permitted		not permitted		-	
3100801.1304	Pre-need purchase of certificate for memorial plaque position	Yes		not permitted		not permitted		-	

Schedule of Fees and Charges 2021/22

GL CODE	DESCRIPTION	GST (inc)	Statutory fee "S"	2020/21	Legislative Authority	Proposed 2021/22	Comment	%increase 20/21 to 21/22	2020/21 YTD Income
BUSINESS UNIT: RECREATION & CULTURE									
Public Halls & Civic Centres									
Town Hall & Reception Centre (Commercial Usage)									
3110100.1302	Town Hall Complex full day (Includes light & sound equipment if approved by CEO/EMCCS) (Excludes Mayors Parlour and Nexus Gallery)	Yes		602.00	\$6.16 LGA	610.00		1%	8,051.35
3110100.1302	Town Hall Complex (Excludes Mayors Parlour and Nexus Gallery) hourly rate	Yes		87.00	\$6.16 LGA	90.00		3%	
3110100.1302	Town Hall full day	Yes		357.00	\$6.16 LGA	360.00		1%	
3110100.1302	Town Hall hourly rate	Yes		77.00	\$6.16 LGA	80.00		4%	
3110100.1302	Town Hall setting up full day	Yes		117.00	\$6.16 LGA	120.00		3%	
3110100.1302	Town Hall rehearsals hourly rate	Yes		26.00	\$6.16 LGA	27.00		4%	
3110100.1302	Kitchen only per day	Yes		199.00	\$6.16 LGA	205.00		3%	
3110100.1302	Kitchen only per hour	Yes		41.00	\$6.16 LGA	42.00		2%	
3110100.1302	Cutlery and crockery hire per person			0.00	\$6.16 LGA	0.00		-	
3110100.1302	Damaged cutlery and crockery will be replaced at a charge of direct replacement cost plus 20% Administration charge	Yes		Cost plus 20%	\$6.16 LGA	Cost plus 20%		-	
3110100.1302	Light & sound equipment Use (not for relocation) (hires to persons deemed by CEO or EMCCS to have the skills to use)	Yes		51.00	\$6.16 LGA	52.00		2%	
3110100.1302	Supper room full day	Yes		158.00	\$6.16 LGA	160.00		1%	
3110100.1302	Supper room per hour	Yes		31.00	\$6.16 LGA	32.00		3%	
3110100.1302	Mayors Parlour full day	Yes		158.00	\$6.16 LGA	160.00		1%	
3110100.1302	Mayors Parlour per hour	Yes		31.00	\$6.16 LGA	32.00		3%	
3110100.1302	Baby grand piano full day (not to be removed from site)	Yes		102.00	\$6.16 LGA	105.00		3%	
3110100.1302	Baby grand piano hourly rate	Yes		15.00	\$6.16 LGA	15.00		-	
3110100.1302	Upright piano hire (internal) (to be retuned on return to Town Hall)	Yes		20.00	\$6.16 LGA	20.00		-	
3110100.1302	Upright piano hire (external) (the Hirer is to fund all relocation costs and retune the piano on return to the Town Hall)	Yes		Cost plus 20%	\$6.16 LGA	Cost plus 20%		-	
3110100.1302	Reception Centre full day	Yes		408.00	\$6.16 LGA	410.00		0%	
3110100.1302	Reception Centre hourly rate	Yes		62.00	\$6.16 LGA	65.00		5%	
3110100.1302	Cleaning	Yes		Cost plus 20%	\$6.16 LGA	Cost plus 20%		-	
3110100.1302	Setting up hourly rate (per staff member involved) (minimum 1 hour charge)	Yes		90.00	\$6.16 LGA	90.00		-	
3110100.1302	Nexus Gallery full day	Yes		0.00	\$6.16 LGA	0.00		-	
3110100.1302	Nexus Gallery hourly rate	Yes		0.00	\$6.16 LGA	0.00		-	
3110100.1302	Nexus Gallery Art hire per day	Yes		0.00	\$6.16 LGA	0.00		-	
	CEO is given authority to negotiate a hire fee for significant functions and conferences at the JHCC and Town Hall	Yes						-	
	Bond without alcohol			337.00	\$6.16 LGA	340.00		1%	
	Bond with alcohol			1,122.00	\$6.16 LGA	1,130.00		1%	
Town Hall & Reception Centre (Not for Profit(*)/Individual Resident or Ratepayer (Not a business))									
3110100.1302	Town Hall Complex full day (Includes Light & Sound Equipment if approved by CEO/EMCCS) (Excludes Mayors Parlour and Nexus Gallery)	Yes		204.00	\$6.16 LGA	207.00		1%	
3110100.1302	Town Hall Complex (Excludes Mayors Parlour and Nexus Gallery) hourly rate	Yes		31.00	\$6.16 LGA	32.00		3%	
3110100.1302	Town Hall full day	Yes		153.00	\$6.16 LGA	155.00		1%	
3110100.1302	Town Hall hourly rate	Yes		26.00	\$6.16 LGA	27.00		4%	
3110100.1302	Town Hall setting up full day	Yes		153.00	\$6.16 LGA	155.00		1%	
3110100.1302	Town Hall rehearsals hourly rate	Yes		26.00	\$6.16 LGA	27.00		4%	
3110100.1302	Kitchen only per day	Yes		102.00	\$6.16 LGA	105.00		3%	
3110100.1302	Kitchen only per hour	Yes		21.00	\$6.16 LGA	22.00		5%	
3110100.1302	Damaged cutlery and crockery will be replaced at a charge of direct replacement cost plus 20% Administration charge	Yes		Cost plus 20%	\$6.16 LGA	Cost plus 20%		-	
3110100.1302	Light & sound equipment use (not for relocation) (hires to persons deemed by CEO or EMCCS to have the skills to use)	Yes		31.00	\$6.16 LGA	32.00		3%	

Schedule of Fees and Charges 2021/22

GL CODE	DESCRIPTION	GST (inc)	Statutory fee "S"	2020/21	Legislative Authority	Proposed 2021/22	Comment	%increase 20/21 to 21/22	2020/21 YTD Income
3110100.1302	Supper Room full day	Yes		77.00	\$6.16 LGA	80.00		4%	
3110100.1302	Supper Room per hour	Yes		15.50	\$6.16 LGA	16.00		3%	
3110100.1302	Mayors Parlour full day	Yes		77.00	\$6.16 LGA	80.00		4%	
3110100.1302	Mayors Parlour per hour	Yes		15.50	\$6.16 LGA	16.00		3%	
3110100.1302	Baby grand piano full day (not to be removed from site)	Yes		51.00	\$6.16 LGA	52.00		2%	
3110100.1302	Baby grand piano hourly rate (not to be removed from site)	Yes		10.50	\$6.16 LGA	11.00		5%	
3110100.1302	Upright piano hire (Internal) (to be returned on return to Town Hall)	Yes		15.50	\$6.16 LGA	16.00		3%	
3110100.1302	Upright piano hire (External) (The Hirer is to fund all relocation costs and retune the piano on return to the Town Hall)	Yes		Cost plus 20%	\$6.16 LGA	Cost plus 20%		-	
3110100.1302	Reception Centre full day	Yes		204.00	\$6.16 LGA	155.00	Note: previously at same rate as the entire complex. Now reflects same as Town Hall full day.	(24%)	
3110100.1302	Reception Centre hourly rate	Yes		31.00	\$6.16 LGA	27.00	Note: previously at same rate as the entire complex. Now reflects same as Town Hall hourly rate.	(13%)	
3110100.1302	Setting up hourly rate (per staff member involved) (minimum 1 hour charge)	Yes		90.00	\$6.16 LGA	Cost plus 20%		-	
3110100.1302	Cleaning	Yes		Cost plus 20%	\$6.16 LGA	90.00		-	
	CEO is given authority to negotiate a hire fee for significant functions and conferences at the JHCC and Town Hall	Yes						-	
	Bond without alcohol			280.00	\$6.16 LGA	285.00		2%	
	Bond with alcohol			560.00	\$6.16 LGA	575.00		3%	
	(* Any function or event that is subject to the 'Not for Profit' Fees and Charges rates must acknowledge the Shire sponsorship at the function/event.				\$6.16 LGA			-	
	John Higgins Community Complex							-	
3110100.1302	Fees and Charges to be provided by the YMCA.				\$6.16 LGA			-	
3110100.1302	Office standard size per year (if not on a lease agreement)	Yes		1,260.00	\$6.16 LGA			(100%)	
3110100.1302	Office large size per year (if not on a lease agreement)	Yes		1,525.00	\$6.16 LGA			(100%)	
Other Recreation									
	Sportsgrounds							-	
3110301.1302	Half day hire (schools & non sporting organisations)	Yes		76.00	\$6.16 LGA	78.00		3%	
3110301.1302	Full day hire (schools & non sporting organisations)	Yes		152.00	\$6.16 LGA	155.00		2%	
3110301.1302	Half day hire commercial	Yes		242.00	\$6.16 LGA	247.00		2%	
3110301.1302	Full day commercial	Yes		404.00	\$6.16 LGA	412.00		2%	
3110301.1302	Narrogin Towns Cricket Club - yearly charge	Yes		1,328.00	\$6.16 LGA	1,355.00		2%	
3110301.1302	Narrogin Hawks Football Club - yearly charge	Yes		3,075.00	\$6.16 LGA	3,137.00		2%	
	Bond for commercial use	Yes		2,333.00	\$6.16 LGA	2,380.00		2%	
	Bond for community use if required by the EMCCS	Yes		581.00	\$6.16 LGA	593.00		2%	

Schedule of Fees and Charges 2021/22

GL CODE	DESCRIPTION	GST (inc)	Statutory fee "S"	2020/21	Legislative Authority	Proposed 2021/22	Comment	%increase 20/21 to 21/22	2020/21 YTD Income
Narrogin Regional Recreation Centre									
Narrogin Regional Leisure Centre (NRLC)									
Fees and Charges provided by the YMCA.									
Aquatics (Casual)									
	Adult Swim	Yes		6.00	\$6.16 LGA	6.00		-	-
	Child Swim -U10 (Supervised)	Yes		1.00	\$6.16 LGA	0.00		(100%)	-
	Concession Swim	Yes		5.00	\$6.16 LGA	5.00		-	-
	Family Swim	Yes		20.00	\$6.16 LGA	20.00		-	-
	Concession Family Swim	Yes		13.90	\$6.16 LGA	13.90		-	-
	Spectator (Over 9 yrs)	Yes		1.00	\$6.16 LGA	1.00		-	-
Visit Passes (Book of 10)									
	Adult	Yes		54.00	\$6.16 LGA	54.00		-	-
	Child	Yes		45.00	\$6.16 LGA	45.00		-	-
Lane Hire									
	Lane Hire	Yes		8.20	\$6.16 LGA	8.20		-	-
	Inflatable Hire	Yes		82.20	\$6.16 LGA	82.20		-	-
Schools									
	Vacation Swimming	Yes		3.60	\$6.16 LGA	3.60		-	-
	In Term Swimming	Yes		2.60	\$6.16 LGA	2.60		-	-
Casual Group Fitness									
	Aqua Aerobics	Yes		15.00	\$6.16 LGA	15.00		-	-
	Aqua Aerobics (Concession)	Yes		12.00	\$6.16 LGA	12.00		-	-
	Group Fitness	Yes		15.00	\$6.16 LGA	15.00		-	-
	Group Fitness (Concession)	Yes		12.00	\$6.16 LGA	12.00		-	-
	Spin	Yes		15.00	\$6.16 LGA	15.00		-	-
Casual Gym									
	Gym - Casual	Yes		13.00	\$6.16 LGA	13.00		-	-
	Gym - Concession	Yes		10.50	\$6.16 LGA	10.50		-	-
Memberships (per fortnight)									
Full membership includes gym, swim & group fitness									
	Full Centre Membership	Yes		40.00	\$6.16 LGA	40.00		-	-
	Full Centre Membership Joining Fee	Yes		45.00	\$6.16 LGA	45.00		-	-
	Full Centre Membership (Concession)	Yes		33.50	\$6.16 LGA	33.50		-	-
	Full Centre Membership Joining Fee (Concession)	Yes		18.00	\$6.16 LGA	18.00		-	-
	Full Centre Family Membership	Yes		80.00	\$6.16 LGA	80.00		-	-
	Full Centre Family Membership Joining Fee	Yes		90.00	\$6.16 LGA	90.00		-	-
	Gym Membership	Yes		28.00	\$6.16 LGA	30.00		7%	-
	Gym Membership Joining Fee	Yes		45.00	\$6.16 LGA	45.00		-	-
	Gym Membership (Concession)	Yes		22.00	\$6.16 LGA	24.00		9%	-
	Gym Membership Joining Fee (Concession)	Yes		18.00	\$6.16 LGA	18.00		-	-
	Aquatic Membership	Yes		28.00	\$6.16 LGA	30.00		7%	-
	Aquatic Membership Joining Fee	Yes		45.00	\$6.16 LGA	45.00		-	-
	Aquatic Membership Fee (Child) - Under 10			0.00	\$6.16 LGA	0.00		-	-
	Aquatic Membership Joining Fee (Child)			0.00	\$6.16 LGA	0.00		-	-
	Aquatic Membership Fee (Concession)	Yes		22.00	\$6.16 LGA	24.00		9%	-
	Aquatic Membership Joining Fee (Concession)	Yes		18.00	\$6.16 LGA	18.00		-	-

Schedule of Fees and Charges 2021/22

GL CODE	DESCRIPTION	GST (inc)	Statutory fee "S"	2020/21	Legislative Authority	Proposed 2021/22	Comment	%increase 20/21 to 21/22	2020/21 YTD Income
Group Fitness									
	Group Fitness Membership Fee	Yes		30.00	\$6.16 LGA	30.00		-	-
	Group Fitness Membership Joining Fee	Yes		45.00	\$6.16 LGA	45.00		-	-
	Group Fitness Membership (Concession)	Yes		24.00	\$6.16 LGA	24.00		-	-
	Group Fitness Membership Joining Fee (Concession)	Yes		18.00	\$6.16 LGA	18.00		-	-
Swimming Lessons (10 weeks)									
	Swimming Lessons Per Term	Yes		110.00	\$6.16 LGA	110.00		-	-
	Swimming Lessons Per Term (Concession)	Yes		88.00	\$6.16 LGA	88.00		-	-
Stadium									
	Social Sports Game Fees	Yes		60.00	\$6.16 LGA	60.00		-	-
	Social Sports Registration Fee	Yes		80.00	\$6.16 LGA	80.00		-	-
	Adult Sports Court Entry	Yes		6.00	\$6.16 LGA	6.00		-	-
	Concession Sports Court Entry	Yes		4.80	\$6.16 LGA	4.80		-	-
	Basketball Association Indoor Court Hire (Per Hour)	Yes		60.00	\$6.16 LGA	60.00		-	-
	Netball Association Indoor Court Hire (Per Hour)	Yes		60.00	\$6.16 LGA	60.00		-	-
	Netball Association Outdoor Court Hire (Per Hour)	Yes		50.00	\$6.16 LGA	50.00		-	-
	Spectator (Over 9yrs) (Operational Discretion)	Yes		1.00	\$6.16 LGA	1.00		-	-
	Forfeit Fee	Yes		58.00	\$6.16 LGA	58.00		-	-
Squash									
	Squash Court Hire Per Hour	Yes		15.00	\$6.16 LGA	15.00		-	-
	Squash Court Hire Per Hour (Concession)	Yes		12.00	\$6.16 LGA	12.00		-	-
	Adult Squash Per Hour	Yes		7.50	\$6.16 LGA	7.50		-	-
	Concession Squash Per Hour	Yes		6.00	\$6.16 LGA	6.00		-	-
Synthetic Hockey Pitch									
	Annual UGSHA Charge for lease of Pitch (Agreement Expires 30/6/21)	Yes		75,000.00	\$6.16 LGA	75,000.00		-	-
	Annual Narrogin Senior High School Facilities Charge			10,000.00	\$6.16 LGA	10,000.00		-	-
	Narrogin High Academy	Yes		28.00	\$6.16 LGA	28.00		-	-
	Full pitch hire per hour	Yes		135.00	\$6.16 LGA	135.00		-	-
	Full pitch hire per hour (Concession)	Yes		100.00	\$6.16 LGA	100.00		-	-
Childcare (per child) \$4.00 per hour									
	Creche one session (1.5hrs) member	Yes		6.00	\$6.16 LGA	7.50		25%	-
	Creche - one session (1.5hrs) non-member	Yes		9.00	\$6.16 LGA	13.50		50%	-
	Creche 10 pass (members)	Yes		54.00	\$6.16 LGA	67.50		25%	-
	Creche 10 pass (Non members)	Yes		81.00	\$6.16 LGA	121.50		50%	-
	Move and Groove				\$6.16 LGA	8.00 New			-
	Kindy Gym	Yes		4.50	\$6.16 LGA	5.00		11%	-
	Child term Program Cost	Yes		100.00	\$6.16 LGA	100.00		-	-
School Usage (per child)									
	Hockey Turf	Yes		2.60	\$6.16 LGA	2.60		-	-
	Squash	Yes		2.60	\$6.16 LGA	2.60		-	-
	Stadium	Yes		2.60	\$6.16 LGA	2.60		-	-
	Outdoor Netball	Yes		2.60	\$6.16 LGA	2.60		-	-
	Gym	Yes		5.50	\$6.16 LGA	5.50		-	-
	Pool entry	Yes		2.60	\$6.16 LGA	2.60		-	-

Schedule of Fees and Charges 2021/22

GL CODE	DESCRIPTION	GST (inc)	Statutory fee "S"	2020/21	Legislative Authority	Proposed 2021/22	Comment	%increase 20/21 to 21/22	2020/21 YTD Income
John Higgins Community Complex									
	Hall hire full day	Yes		555.00	\$6.16 LGA	560.00		1%	-
	Hall hire half day	Yes		290.00	\$6.16 LGA	290.00		-	-
	Half Hall Full day	Yes		277.50	\$6.16 LGA	280.00		1%	-
	Half Hall half day	Yes		145.00	\$6.16 LGA	145.00		-	-
	Hall Hire per hour	Yes		75.00	\$6.16 LGA	75.00		-	-
	Half Hall Hire per hour	Yes		37.50	\$6.16 LGA	37.50		-	-
	Kitchen Hire - additional flat rate per hall booking	Yes		50.00	\$6.16 LGA	50.00		-	-
	Kitchen Hire per hour	Yes		30.00	\$6.16 LGA	30.00		-	-
	Out of Hours staffing fee (per hour or part thereof)	Yes		50.00	\$6.16 LGA	50.00		-	-
Office Lease - per week									
	JHCC - 3m x 3m - Office 1 - WAFC (WA Football Commission)	Yes		80.00	\$6.16 LGA	80.00		-	-
	JHCC - 3m x 3m - Office 2 - NDNA (Narrogin District Netball Association)	Yes		10.00	\$6.16 LGA	10.00		-	-
	JHCC - 3m x 3m - Office 3 - NJBA (Narrogin Junior Basket Ball Association)	Yes		10.00	\$6.16 LGA	10.00		-	-
	JHCC - 3m x 3m - Office 4 - UGSHA (hire included in agreed annual payment) (Upper Great Southern Hockey Association)	Yes		0.00	\$6.16 LGA	0.00		-	-
	JHCC - 3m x 3m - Office 5 - Parents Next	Yes		80.00	\$6.16 LGA	80.00		-	-
	JHCC - 3m x 3m - Office 6 - Ag Society (\$300 pa per agreement expiring 30/6/20)	Yes		300pa	\$6.16 LGA	300pa		-	-
	Internal - 6m x 3m office (Nb Toy Library free)	Yes		0.00	\$6.16 LGA	0.00		-	-
	Internal - 8m x 3m office FULL HIRE (Nb DSR (Dept of Sport & Recreation) portion @ \$104.50pw)	Yes		104.50	\$6.16 LGA	104.50		-	-
	Internal - 10m x 3m office FULL HIRE	Yes			\$6.16 LGA	300.00		-	-
	Internal - 10m x 3m office HALF HIRE	Yes			\$6.16 LGA	150.00		-	-
	Existing NFP Club Hires (Ag, Netball, UGSHA) (AG Soc lease \$300pa expires 30/6/20)	Yes		10.00	\$6.16 LGA	10.00		-	-
NB: Above rentals apply whilst current tenants continue to occupy. When vacated the following rentals apply.									
	3m x 3m offices are rented by commercial tenants	Yes		90.00	\$6.16 LGA	90.00		-	-
	8m x 3m (Full) offices are rented by commercial tenants	Yes		240.00	\$6.16 LGA	240.00		-	-
	8m x 3m (Half) offices are rented by commercial tenants	Yes		120.00	\$6.16 LGA	120.00		-	-
Sports Grounds									
	Thomas Hogg, Clayton Rd & Centre Sports								-
	Hourly Rate	Yes		17.50	\$6.16 LGA	17.50		-	-
	Half Day Hire (4hrs)	Yes		70.00	\$6.16 LGA	70.00		-	-
	Full Day Hire (8hrs)	Yes		140.00	\$6.16 LGA	140.00		-	-
	Kiosk all items at weighted average cost plus 100% markup*								-
Whole Facility									
	Agricultural Show or similar whole of facility hire (N.B.Narrogin Agricultural Show payable by the Shire)	Yes		5,000.00	\$6.16 LGA	5,000.00		-	-

Schedule of Fees and Charges 2021/22

GL CODE	DESCRIPTION	GST (inc)	Statutory fee "S"	2020/21	Legislative Authority	Proposed 2021/22	Comment	%increase 20/21 to 21/22	2020/21 YTD Income
Libraries									
<u>RW (Bob) Farr Memorial Library</u>									
3110500.1304	Email access 30 minutes	Yes		2.00	\$6.16 LGA	2.00		-	-
3110501.1301	First overdue notice - book	Yes		0.00	\$6.16 LGA	0.00		-	2,977.65
3110501.1301	Second overdue notice - book	Yes		0.00	\$6.16 LGA	0.00		-	-
3110501.1301	Lost or damaged book/dvd	Yes		cost	\$6.16 LGA	cost		-	332.80
3110500.1304	Handling fee for invoice	Yes		13.25	\$6.16 LGA	13.25		-	-
3110500.1304	Laminating A4 size	Yes		2.05	\$6.16 LGA	2.05		-	-
3110500.1304	Laminating A3 size	Yes		4.10	\$6.16 LGA	4.10		-	-
3110500.1304	Scanning per page	Yes		2.05	\$6.16 LGA	2.05		-	-
3110500.1304	Disk repair (CD/DVD)	Yes		5.10	\$6.16 LGA	5.10		-	-
3110500.1304	Disk cleaning (CD/DVD)	Yes		2.05	\$6.16 LGA	2.05		-	-
3110500.1304	A4 Single sided photocopy per copy	Yes		0.45	\$6.16 LGA	0.45		-	-
3110500.1304	A3 & A4 double sided photocopy per copy	Yes		0.60	\$6.16 LGA	0.60		-	-
3110500.1304	A3 double sided per copy	Yes		0.80	\$6.16 LGA	0.80		-	-
3110500.1304	A4 single sided colour per copy	Yes		2.05	\$6.16 LGA	2.05		-	-
3110500.1304	A3 single & A4 double sided colour per copy	Yes		4.10	\$6.16 LGA	4.10		-	-
3110500.1304	Coffee / Tea (if provided by the Shire)	Yes		2.05	\$6.16 LGA	2.05		-	-
3110500.1304	Restricted wireless internet access	Yes		Free	\$6.16 LGA	Free		-	-
3110500.1304	Historical research (Town & Shire of Narrogin residence) e.g. family history per hour	Yes		35.00	\$6.16 LGA	35.00		-	-
3110500.1304	Historical research (Non Town or Shire of Narrogin residence)e.g. family history per hour	Yes		60.00	\$6.16 LGA	60.00		-	-
	Sale of other Items at RRP or cost plus 20% which ever is the higher.				\$6.16 LGA			-	-
BUSINESS UNIT: TRANSPORT									
Transport									
<u>Aerodrome</u>									
3120405.1304	Major user charge per year (Note not to be charged to the Narrogin Gliding or Flying Clubs)	Yes		850.00	\$6.16 LGA	850.00		-	-
3120405.1304	Minor user charge per year (Note not to be charged to the Narrogin Gliding or Flying Clubs)	Yes		510.00	\$6.16 LGA	510.00		-	-
<u>Road Numbering</u>									
3120212.1103	Rural property numbering	Yes		41.00	\$6.16 LGA	42.00		2%	-

Schedule of Fees and Charges 2021/22

GL CODE	DESCRIPTION	GST (inc)	Statutory fee "S"	2020/21	Legislative Authority	Proposed 2021/22	Comment	%increase 20/21 to 21/22	2020/21 YTD Income
BUSINESS UNIT: ECONOMIC SERVICES									
Tourism and Area Promotion									
Narrogin Caravan Park									
3130200.1303	Caravan site fees per day (up to 2 adults and 2 children)	Yes		33.00	\$6.16 LGA	34.00		3%	228,268.50
3130200.1303	Caravan site fees per half day (up to 2 adults and 2 children)	Yes		16.50	\$6.16 LGA	17.00		3%	
3130200.1303	Caravan site fees per week (up to 2 adults and 2 children) up to the first four weeks	Yes		165.00	\$6.16 LGA	167.00		1%	
3130200.1303	Caravan site fees per week (up to 2 adults and 2 children) after the first four weeks	Yes		155.00	\$6.16 LGA	157.00		1%	
3130200.1303	Each additional person caravan site single night	Yes		8.00	\$6.16 LGA	8.50		6%	
3130200.1303	Each additional person caravan site weekly	Yes		48.00	\$6.16 LGA	50.00		4%	
3130200.1303	Camping site fees (no power) (up to 2 adults and 2 children of the same family) per day	Yes		15.00	\$6.16 LGA	15.00		-	
3130200.1303	Camping site fees (power) (up to 2 adults and 2 children of the same family) per day	Yes		25.00	\$6.16 LGA	25.00		-	
3130200.1303	Additional person camping site (no power)	Yes		6.00	\$6.16 LGA	6.00		-	
3130200.1303	Additional person camping site (power)	Yes		8.00	\$6.16 LGA	8.00		-	
	Caravan park site and camping fees should be paid in advance. However if payment is made in arrears additional fees may apply.								
3130200.1303	Penalty fee for late payment of site or camping fees	Yes		6.00	\$6.16 LGA	6.00		-	
3130200.1303	Washing machines per cycle	Yes		5.00	\$6.16 LGA	5.00		-	
3130200.1303	Driers up to approximately 30 minutes	Yes		4.00	\$6.16 LGA	4.00		-	
3130200.1303	Letter box rental per month	Yes		6.00			Service no longer provided	(100%)	
3130200.1303	Caravan storage (caravan not to be sited at a caravan site and unoccupied) per week	Yes		128.00	\$6.16 LGA	130.00		2%	
3130200.1303	Self contained RV (short stay) (not using any of the CP facilities) per night (subject to the official RV site being within the Narrogin caravan site)	Yes		6.00	\$6.16 LGA	6.00		-	
3130200.1303	Use of showers and/or toilet only per use (persons not stay in caravan park) subject to the approval of the Shire	Yes		6.00	\$6.16 LGA	6.00	clarification of use	-	
Accommodation units									
3130200.1303	Accommodation Unit per night (2 People)	Yes		120.00	\$6.16 LGA	122.00		2%	
3130200.1303	Accommodation Unit per night - Additional Person	Yes		20.00	\$6.16 LGA	21.00		5%	
3130200.1303	Accommodation Unit per night (2 People) 2-6 Nights	Yes		110.00	\$6.16 LGA	112.00		2%	
3130200.1303	Accommodation Unit per night - 2-6 Nights Additional Person	Yes		20.00	\$6.16 LGA	21.00		5%	
3130200.1303	Accommodation Unit per week (2 People) Full Week 7 - 14 Nights	Yes		660.00	\$6.16 LGA	673.00		2%	
3130200.1303	Accommodation Unit per night - Full Week Additional person	Yes		20.00	\$6.16 LGA	21.00		5%	
3130200.1303	Accommodation Unit per week (2 People) Long than 2 weeks	Yes		600.00	\$6.16 LGA	612.00		2%	
3130200.1303	Accommodation Unit per week (2 People) Long than 2 weeks Vacate Clean	Yes		250.00	\$6.16 LGA	255.00		2%	
	For stays longer than a full week a 10% deposit is required. Cancellation of these bookings less than 24 hours prior to stay will forfeit the deposit.								
Other Tourism & Area Promotion									
3130204.1304	Shire number plates (transfer of plates not included)	Yes		Cost plus 20%	\$6.16 LGA	Cost plus 20%		-	436.33
3130200.1303	Sale of other promotional material at RRP or cost plus 20%	Yes		RRP or Cost plus 20%	\$6.16 LGA	RRP or Cost plus 20%		-	
3130200.1303	RV permit fee (at approved RV sites external to the Caravan Park)	Yes		NIL		NIL		-	

Schedule of Fees and Charges 2021/22

GL CODE	DESCRIPTION	GST (inc)	Statutory fee "S"	2020/21	Legislative Authority	Proposed 2021/22	Comment	%increase 20/21 to 21/22	2020/21 YTD Income
Building Control									
Building Services									
3130300.1304	Building Surveyor hourly rate	Yes		92.50	S6.16 LGA	92.50		-	-
3130300.1304	Trainee Building Surveyor charge hourly rate	Yes		70.00	S6.16 LGA	70.00		-	14,173.50
3130300.1304	Vehicles mileage rate	Yes		1.50	S6.16 LGA	1.50		-	-
3130300.1304	Retrieval of building plans	Yes		50.00	S6.16 LGA	50.00		-	-
3130300.1304	Class 1 & 10 Building Permit fee 0.32% - minimum		S	105.00	Sch 2 BR	110.00		5%	-
3130300.1304	Class 2-9 Building Permit fee 0.09% - minimum		S	105.00	Sch 2 BR	110.00		5%	-
BUILDING	Building Services Levy fee 0.137% - minimum		S	61.65	R 12 BS	61.65		-	-
BUILDING	Building Industry Fund .2% (once work over \$20,000 value)		S					-	-
T4	Footpath, kerb and road deposit (per street frontage) 1% of value of proposed works with a minimum of \$1,500		S	1,500.00	Sch 2 BR	1,500.00		-	-
3130300.1304	Certificate of Design Compliance as per staff time (\$340 min) or 0.2%, whichever is greater - minimum		S	340.00	Sch 2 BR	340.00		-	-
3130300.1304	Certificate of Built Compliance - as per staff time (\$340 min) or 0.2%, whichever is greater - minimum		S	340.00	Sch 2 BR	340.00		-	-
3130300.1304	Certificates of Construction Compliance - as per staff time (\$340 min) or 0.2%, whichever is greater - minimum		S	340.00	Sch 2 BR	340.00		-	-
3130300.1304	Approval of battery powered smoke alarms		S		R61 BR	179.40		-	-
3130300.1304	Other charges as per the Building Regulations 2012		S		Sch 2 BR			-	-
3130300.1304	Swimming pool inspection fee (\$58.45/4 years) Reg 53 Building Regulations 2012		S	14.61	R 53 BR	14.61		-	-
3130300.1304	Bushfire Attack Level Certification							-	-
3130300.1304	—Single dwelling			150.00			Specialist Qualifications required which current staff do not possess.	(100%)	-
3130300.1304	—each additional dwelling			120.00				(100%)	-
Other Economic Services									
3130607.1304	Commercial Stand pipe per 1,000L	Yes		6.54	S6.16 LGA	6.60		1%	15,438.28
3130607.1304	Commercial Stand pipe access swipe card	Yes		20.00	S6.16 LGA	20.00		-	-
Advertising and Sponsorship signs (policy 11.5)									
3130604.1304	Naming Rights Sponsor				S6.16 LGA	1,000.00	New	-	-
3130604.1304	Long Term Sponsor				S6.16 LGA		New	-	-
3130604.1304	Small (up to 60cm X 90cm)				S6.16 LGA	100.00	New	-	-
3130604.1304	Large up to 120cm x 240cm				S6.16 LGA	200.00	New	-	-
3130604.1304	Oversize				S6.16 LGA	As determined by Council	New	-	-
3130604.1304	Seasonal Sponsor				S6.16 LGA		New	-	-
3130604.1304	Small (up to 60cm X 90cm)				S6.16 LGA	100.00	New	-	-
3130604.1304	Large up to 120cm x 240cm				S6.16 LGA	200.00	New	-	-
3130604.1304	Oversize				S6.16 LGA	As determined by Council	New	-	-
3130604.1304	Event Sponsor				S6.16 LGA	As determined by Facility Manager	New	-	-
3130604.1304	Community/ Not for Profit/ Service Group				S6.16 LGA	As determined by Facility Manager	New	-	-
3130604.1304	Small (up to 60cm X 90cm)				S6.16 LGA	As determined by Facility Manager	New	-	-
3130604.1304	Large up to 120cm x 240cm				S6.16 LGA	As determined by Facility Manager	New	-	-
3130604.1304	Oversize				S6.16 LGA	As determined by Facility Manager	New	-	-

Schedule of Fees and Charges 2021/22

GL CODE	DESCRIPTION	GST (inc)	Statutory fee "S"	2020/21	Legislative Authority	Proposed 2021/22	Comment	%increase 20/21 to 21/22	2020/21 YTD Income
BUSINESS UNIT: OTHER PROPERTY & SERVICES									
Private Works									
Charge Out Rates for Private Works									
<i>With Operator (Labour rates included in price)</i>									
3140100.1304	Grader per hour	Yes		188.00	S6.16 LGA	190.00		1%	111,778.80
3140100.1304	Loader per hour	Yes		174.00	S6.16 LGA	176.00		1%	
3140100.1304	Backhoe per hour	Yes		134.00	S6.16 LGA	135.00		1%	
3140100.1304	Truck (12 tonne) per hour	Yes		175.00	S6.16 LGA	177.00		1%	
3140100.1304	Truck (3 tonne) per hour	Yes		145.00	S6.16 LGA	146.00		1%	
3140100.1304	Truck & float per hour	Yes		225.00	S6.16 LGA	227.00		1%	
3140100.1304	Jet patcher per hour	Yes		167.00	S6.16 LGA	169.00		1%	
3140100.1304	Multi-roller per hour	Yes		167.00	S6.16 LGA	169.00		1%	
3140100.1304	Vib (Hamm) roller per hour	Yes		124.00	S6.16 LGA	125.00		1%	
3140100.1304	Excavator per hour	Yes		175.00	S6.16 LGA	177.00		1%	
3140100.1304	Road sweeper per hour	Yes		167.00	S6.16 LGA	169.00		1%	
3140100.1304	JD tractor per hour	Yes		168.00	S6.16 LGA	170.00		1%	
3140100.1304	Bomag vibrating roller per hour	Yes		145.00	S6.16 LGA	146.00		1%	
3140100.1304	Cat multi terrain loader per hour	Yes		138.00	S6.16 LGA	139.00		1%	
3140100.1304	JD backhoe per hour	Yes		134.00	S6.16 LGA	135.00		1%	
3140100.1304	Trailers (truck dog)	Yes		50.00	S6.16 LGA	51.00		2%	
3140100.1304	Slasher (tractor attachment)	Yes		30.00	S6.16 LGA	30.00		-	
3140100.1304	Turf Aerator (tractor attachment)	Yes		30.00	S6.16 LGA	30.00		-	
3140100.1304	New Holland tractor per hour	Yes		168.00	S6.16 LGA	170.00		1%	
3140100.1304	JD ride on mower (with trailer) per hour	Yes		126.00	S6.16 LGA	127.00		1%	
3140100.1304	Toro ride on mower (with trailer) per hour	Yes		126.00	S6.16 LGA	127.00		1%	
3140100.1304	Flail Mower (tractor attachment)	Yes		30.00	S6.16 LGA	30.00		-	
3140100.1304	10 tonne Mitsubishi fuso	Yes		175.00	S6.16 LGA	177.00		1%	
3140100.1304	Tow behind broom per hour	Yes		128.00	S6.16 LGA	129.00		1%	
3140100.1304	Generator hire per day or part there of (commercial)	Yes		510.00	S6.16 LGA	515.00		1%	
3140100.1304	Generator hire per day or part there of (non commercial)	Yes		255.00	S6.16 LGA	258.00		1%	
3140100.1304	Materials, Contracts, Plant & Labour Rates	Yes		Cost plus 20%	S6.16 LGA	Cost plus 20%		-	
3140100.1304	Labour rate (normal @ normal hours)	Yes		90.00		Delete		(100%)	
3140100.1304	Works crew labour per hour	Yes		90.00	S6.16 LGA	91.00		1%	
3140100.1304	Works Foreman per hour	Yes		112.00	S6.16 LGA	113.00		1%	
3140100.1304	Operations Manager	Yes		123.00	S6.16 LGA	124.00		1%	
3140100.1304	Mileage rate per km	Yes		1.50	S6.16 LGA	1.52		1%	
3140100.1304	Gravel per Cubic metre ex pit excluding delivery	Yes		5.00	S6.16 LGA	10.00		100%	
	* No dry hire of plant. Only experienced ticketed Shire staff to operate plant at discretion of CEO or EMTRS							-	
	All other charges not separately listed in this schedule that is not set by specific legislation	Yes		Cost plus 20%	S6.16 LGA			-	
3120214.1300	Gate Permits	Yes			S6.16 LGA	250.00	Initial application fee	-	

Schedule of Fees and Charges 2021/22

GL CODE	DESCRIPTION	GST (inc)	Statutory fee "S"	2020/21	Legislative Authority	Proposed 2021/22	Comment	%increase 20/21 to 21/22	2020/21 YTD Income
Administration									
Administration/Office									
3040203.1304	Photocopy charges - single A4 per copy	Yes		0.50	\$6.16 LGA	0.50		-	-
3040203.1304	Photocopy charges - single A3 per copy	Yes		1.00	\$6.16 LGA	1.00		-	-
3040203.1304	Photocopy charges - A4 single colour per copy	Yes		2.00	\$6.16 LGA	2.00		-	-
3040203.1304	Photocopy charges - A4 double / A3 single colour per copy	Yes		4.00	\$6.16 LGA	4.00		-	-
3040204.1304	Minutes or Agendas (free at council meeting)	Yes		25.00	\$6.16 LGA	25.00		-	-
3040206.1304	Digital projector per day	Yes		36.00	\$6.16 LGA	36.00		-	295.88
3040206.1304	Portable wireless speaker (individual)	Yes		33.00	\$6.16 LGA	33.00		-	-
3040206.1304	Portable wireless speakers (pair)	Yes		55.00	\$6.16 LGA	55.00		-	-
3040101.1302	Council chambers full day	Yes		400.00	\$6.16 LGA	400.00		-	46.36
3040101.1302	Council chambers per hour	Yes		51.00	\$6.16 LGA	51.00		-	-
3040101.1302	Meeting room full day	Yes		240.00	\$6.16 LGA	240.00		-	-
3040101.1302	Meeting room per hour	Yes		41.00	\$6.16 LGA	41.00		-	-
3040205.1304	Secretarial support per hour	Yes		71.00	\$6.16 LGA	71.00		-	-
3040206.1304	FOI as per statutory fees	Yes	S	as per Act	\$6.16 LGA	as per Act		-	-
3040206.1304	Cleaning	Yes		Cost plus 20%	\$6.16 LGA	Cost plus 20%		-	-
3140511.1304	IT Officer charge out income (per hour)	Yes		70.00	\$6.16 LGA	71.00		1%	-
	Copy of CCTV Footage (fixed Cost) includes first hour. WAPOL exempt	Yes		100.00	\$6.16 LGA	100.00		-	-
	Copy of CCTV Footage (Hourly fee or part there of) WAPOL exempt	Yes		70.00	\$6.16 LGA	70.00		-	-
3140511.1304	Vehicles mileage rate	Yes		1.50	\$6.16 LGA	1.50		-	-
	Security key bond	Yes		255.00	\$6.16 LGA	255.00		-	-
	Bonds that have been approved by the CEO or EMCCS to be paid by credit cards will attract a fee equal to that of the bank fees paid by the Shire associated with that particular transaction.								

Schedule of Fees and Charges 2021/22

GL CODE	DESCRIPTION	GST (inc)	Statutory fee "S"	2020/21	Legislative Authority	Proposed 2021/22	Comment	%increase 20/21 to 21/22	2020/21 YTD Income
Additional Items about the Shire's Fees and Charges									
Rounding	Fees and Charges are to be rounded down to the nearest 5c.								
Concession Rate	A person who can prove at the time of purchase they are either under 18 years of age or a holder of a Seniors or Health Care Card.								
Bonds	Bonds are to be paid before the hire of facilities, equipment or the supplying of keys. All Bonds are to be paid by Cash or Bank Cheque unless approved by the CEO or EMCCS. If the CEO or EMCCS approve payment of Bond by Credit Card then additional fees will apply and the bond will be increase by 3% to cover the loss of bank fees. The CEO or EMCCS may amend or impose an additional bond for the use of the Shire facilities by any group or individuals where they believe it is in the best interest of the Shire to do so.								
Cleaning Requirements	Unless special arrangements have been agreed to by the Shire, all facilities are to be cleaned to the same standard as the facility was originally hired, at the end of the hire.								
Other	All above figures are in Australian Dollars (AUD).								
Statutory Fees	Any statutory fees imposed by other government agencies are subject to change without warning. Prior to considering change to any of these fees relevant legislation should be read.								
GST	All prices with Yes in the GST column include GST.								
Cost plus 20%	All other charges not separately listed in this schedule that is not set by specific legislation will be charged at cost plus 20%.								

Abbreviations used

ACA	Aged Care Act 1997 (Federal)
BFA	Bushfires Act 1954
BR	Building Regulations 2012
BS	Building Services (Complaint Resolution and Administration) regulations 2011
CA	Cemeteries Act 1986
CR	Cat Regulations 2012
DA	Dog Act 1976
DR	Dog Regulations 2013
FA	Food Act 2008
HA	Health Act 1911
HTS	Health (Treatment of Sewage and Disposal of Effluent and Liquid Waste) Regulations 1974
LG(MP)A	Local Government (Miscellaneous Provisions) Act 1960
LGA	Local Government Act 1995
PDA	Planning and Development Act 2005
PDR	Planning and Development Regulations 2009
WA FOI	WA Freedom of Information Act 1992

10.3.4 RATES AND SUNDRY DEBTORS WRITE OFFS

File Reference	12.7.1, 25.5.8, A340209, A283600
Disclosure of Interest	Neither the Author nor Authorising Officer have any Impartiality, Financial or Proximity Interests that requires disclosure.
Applicant	Shire of Narrogin
Previous Item Numbers	Nil
Date	3 June 2021
Author	Alex Mulenga – Manager of Corporate Services Thomas Baldwin – Rates Officer
Authorising Officer	Frank Ludovico - Executive Manager Corporate & Community Services
Attachments	1. Rates & Sundry Debtor Write Offs – Confidential Attachment under separate cover

Summary

The following information is presented to Council for authorisation to write off both rates and sundry outstanding debts.

Background

As part of the preparation of the Shire's end of year financial accounts, a review of the Shire's outstanding sundry and rates debtors has been undertaken.

All outstanding sundry and rates debtor invoices followed the Shire's debt recovery process, including an offer to contact the Shire should the ratepayer or customer be experiencing any difficulty in making payment. No further action was taken with these invoices as it would cost the Shire more in debt recovery costs than the outstanding amounts.

Authority is also sought to write off a long-standing imbalance in the Pensioner Rebate Claims Clearing Account (General Ledger 1190912030).

Consultation

Consultation has been undertaken with the following officers:

- Executive Manager Corporate & Community Services
- Manager Community Care Services
- Senior Finance Officer (Operations)
- Bob Waddell & Associates (Consultants to Local Government).

Statutory Environment

Section 6.12 (1) (c) of the Local Government Act 1995 states that "a local government may write off any amount of money, which is owed to the local government".

Unrecoverable debts up to the individual value of \$100 may be written off under Council Delegation 3.7, whilst those over \$100 are to be brought to Council for write off on at least an annual basis.

Policy Implications

Nil

Financial Implications

Details of the proposed write offs are shown in the Confidential Attachment. This will reduce the revenue expected to be collected in 2020/2021 by \$22,198.45.

Strategic Implications

Shire of Narrogin Strategic Community Plan 2017-2027	
Objective	4. Civic Leadership Objective (Continually enhance the Shire's organisational capacity to service the needs of a growing community)
Outcome:	4.1 An efficient and effective organisation

Comment/Conclusion

The debts requested to be written off in this report are deemed irrecoverable. See the Confidential Attachment for details.

Voting Requirements

Absolute Majority

OFFICERS' RECOMMENDATION

That, with respect to Rates & Sundry Debtors Write Offs, Council approve the write offs totalling \$22,198.45 as per the confidential attachment.

10.4 OFFICE OF THE CHIEF EXECUTIVE OFFICER

10.4.1 DEED OF VARIATION TO LEASES – NARROGIN BOWLING CLUB & NARROGIN CROQUET CLUB

File Reference	A105214 & A115310
Disclosure of Interest	Neither the Author nor Authorising Officer have any Impartiality, Financial or Proximity Interests that requires disclosure.
Applicant	Narrogin Bowling Club Inc. and Narrogin Croquet Club Inc
Previous Item Numbers	Nil
Date	14 June 2021
Author	Joshua Pomykala – Governance Officer
Authorising Officer	Dale Stewart – Chief Executive Officer
Attachments	<ol style="list-style-type: none">1. Proposed Deed of Variation of Lease2. Original Narrogin Bowling Club lease3. Original Narrogin Croquet Club lease4. Correspondence between the Narrogin Bowling Club and Narrogin Croquet Club

Summary

The Narrogin Bowling Club and the Narrogin Croquet Club have requested a change to the leased areas of their respective clubs.

The Council is asked to consider the proposed Deed of Variation of Lease, with variations to both the Narrogin Bowling Club lease and the Narrogin Croquet Club lease.

Background

Both the Narrogin Bowling Club and Narrogin Croquet Club have current leases with the Shire over separate portions of Lot 1561 Clayton Road. Lot 1561 Clayton Road is a Crown Grant, with the purpose of 'Recreation (Greater Sports Ground)', and extends from May Street (west) to Earl Street (east), abutting Clayton Road to the south and Lot 123 Earl Street ('old golf course') to the north.

The Bowling Club lease is dated from 1 July 1997. Council resolved at its meeting on 28 August 2019, pursuant to resolution number 0819.010, to extend the Club's lease for a further 21 years retrospectively from 1 July 2018, ending 30 June 2039.

The Croquet Club lease is dated from 1 June 2001 and will expire on 31 May 2022. If a further lease is requested, then the variation (if granted) will need to be incorporated in a new lease.

Both leases are for the area located in the south-east portion of Lot 1561, with the facilities adjoining one another. The original Bowling Club lease consists of the clubrooms, maintenance shed and three separate bowling greens (A and B to the southern portion of the Club's clubrooms, and C to the northern portion). The original Croquet Club lease consists of the Club's clubhouse, and two croquet lawns.

Correspondence between the two clubs shows that both are in agreeance with the proposal to move the fences of the Croquet Club's lawn 2 slightly north, and for the Croquet Club to take over the lease of the Bowling Club's green A, whilst also moving the southern and northern fences of the Croquet Club's lawn 2 north by 2.4 metres an 3.4 metres, respectively.

Consultation

Consultation has been undertaken with:

- Chief Executive Officer
- Executive Manager Technical & Rural Services
- Executive Manager Development & Regulatory Services
- Narrogin Croquet Club
- Narrogin Bowling Club.

Statutory Environment

The Local Government Act 1995, Section.3.58, addresses the disposition of property.

Local Government (Function and General) Regulations 1993, Regulation 30, provides for exemptions from the disposition requirements for not for profit community groups (no need to advertise).

Policy Implications

The Council's Policy Manual contains no policies that relate and nor are there any proposed.

Financial Implications

All costs in moving the fences to adjust the boundaries will be met by the Clubs, and the Shire will not be required to meet any additional costs.

There will be no costs in the current northern Bowling Green C moved under the lease of the Narrogin Croquet Club. The Lessee is expected to maintain the upkeep of the premises, therefore responsibility being transferred to the Croquet Club.

Strategic Implications

Shire of Narrogin Strategic Community Plan 2017-2027		
Objective	2.	Social Objective (To provide community facilities and promote social interaction)
Outcome:	2.2	Build a healthier and safer community
Strategy:	2.2.1	Support the provision of community security services and facilities
Outcome:	2.3	Existing strong community spirit and pride is fostered, promoted and encouraged
Strategy:	2.3.2	Engage and support community groups and volunteers
Objective	3.	Environment Objective (Conserve, protect and enhance our natural and built environment)
Outcome:	3.3	Efficient use of resources
Strategy:	3.3.1	Increase resource usage efficiency

Comment/Conclusion

The Narrogin Bowling Club and Narrogin Croquet Club have been in contact with the Shire, requesting that the northern portion of the currently leased area to the Bowling Club, known as Narrogin Bowling Club C green, is changed to be part of the lease for the Narrogin Croquet Club.

The boundaries of the leased area of the Clubs will also change, with the request that the southern fence of the Croquet Club lawn 2 is moved north 2.4 metres, and the northern fence of the same lawn be moved north 3.4 metres. The moving of the fences north will allow the Bowling Club to extend the seating area and allow people ease of movement through the area.

Both parties have agreed that it would be to the benefit of each club for the amendment in their respective leases, with the detailed boundary changes. All other covenants, terms, conditions and stipulations within the leases are to remain the same.

There are no negative implications on the Shire if the northern bowling green is moved under the lease agreement of the Croquet Club. The upkeep of the additional lawn will be the responsibility of the Croquet Club.

Voting Requirements

Simple Majority.

OFFICERS' RECOMMENDATION

That, with respect to the proposed Deed of Variation of Lease with the Narrogin Bowling Club and Narrogin Croquet Club for their existing leases, Council authorise the Shire President and the Chief Executive Officer to prepare, sign and affix the common seal to a Deed of Variation of Lease in the substantive form of the draft attached to this report, delineating the new boundaries of the respective clubs.

2021

SHIRE OF NARROGIN

AND

NARROGIN BOWLING CLUB INC.

AND

NARROGIN CROQUET CLUB INC

DEED OF VARIATION OF LEASE

THIS AGREEMENT is made on _____ 2021

BETWEEN:

Shire of Narrogin in the State of Western Australia, (“the Lessor”) of the one part

AND

Narrogin Bowling Club (Inc.), 58 Earl Street, Narrogin, Western Australia (“the Lessee”) of the other part

AND

Narrogin Croquet Club (Inc), PO Box 248, Narrogin, Western Australia (“the Lessee”) of the other part.

WHEREAS:

a) Pursuant to the Lease Agreements (respectively as “the Lease”) dated:

i. 1 July 1997 (Narrogin Bowling Club Inc.)

ii. 1 June 2001 (Narrogin Croquet Club Inc)

b) The parties wish to vary the lease in the matter set out herein.

IT IS AGREED as follows:

1. Item 1 of the Schedule to the Lease of the Narrogin Bowling Club (Inc.) be varied such that it reads as follows:

“Land

Portion of Lot 1561 Clayton Road, Narrogin, and comprising the Narrogin Bowling Club clubrooms, toilets, Bowling Club A green, and Bowling Club B green as depicted in GREEN outline on Annexure 1.

Premises

That part of the Land depicted on the plan in GREEN outline annexed hereto as Annexure 1, including all buildings, structures, alterations, additions and improvements on that part of the Land, or erected on that part of the Land during the Term.”

2. Replace original Annexure 1 – Aerial view of Premises, with Annexure 1 – Aerial view of Premises (Narrogin Bowling Club) that reflects the Narrogin Bowling Club leased areas, being the Bowling Club A green abutting Clayton Road, and Bowling Club B green, abutting Earl Street.
Bowling Club C green is to be removed from the Lease of the Narrogin Bowling Club.

3. Item 1 of the Schedule to the Lease of the Narrogin Croquet Club (Inc) be varied such that it reads as follows:

“Land

Portion of Lot 1561 Clayton Road, Narrogin, and comprising the Narrogin Croquet Club clubhouse, Croquet Club lawn 1, Croquet Club lawn 2, and Croquet Club lawn 3 as depicted in GREEN outline on Annexure 1.

Premises

That part of the Land depicted on the plan in GREEN outline annexed hereto as Annexure 1, including all buildings, structures, alterations, additions and improvements on that part of the Land, or erected on that part of the Land during the Term.”

4. Replace original Annexure 1 – Aerial view of Premises, with Annexure 1 – Aerial view of Premises (Narrogin Croquet Club) that reflects the Narrogin Croquet Club leased areas, being the Croquet Club lawn 1, Croquet Club lawn 2, and the addition of Croquet Club lawn 3 (being the former Bowling Club C green).
The south fence of the Croquet Club lawn 2 will be moved north 2.4 metres, and the lawn’s northern fence will be moved north 3.4 metres.
5. That all and singular covenants, conditions, stipulations and agreements contained in or implied in the said Leases (except as herein varied) shall be observed and performed by the parties respectively and shall be deemed to apply hereto in the like manner as if set out herein.

EXECUTED AS A DEED

The Common Seal of)
the **Shire of Narrogin** was hereunto)
affixed by authority of a resolution)
of the Council in the presence of:)

Shire President

Signature (Shire President)

Chief Executive Officer

Signature (Chief Executive Officer)

Agreed to by the **Narrogin Bowling Club (Inc.)**
in the presence of:

President (Narrogin Bowling Club)

Signature (President, Narrogin Bowling Club)

Secretary (Narrogin Bowling Club)

Signature (Secretary, Narrogin Bowling Club)

Agreed to by the **Narrogin Croquet Club (Inc)**
in the presence of:

President (Narrogin Croquet Club)

Signature (President, Narrogin Croquet Club)

Secretary (Narrogin Croquet Club)

Signature (Secretary, Narrogin Croquet Club)

Annexure 1 – Aerial view of Premises (Narrogin Bowling Club)



Annexure 1 – Aerial view of Premises (Narrogin Croquet Club)



TOWN OF NARROGIN

and

THE NARROGIN BOWLING CLUB INC.

LEASE

NARROGIN BOWLING CLUB

THIS LEASE is made on the Day of 1997.

BETWEEN

TOWN OF NARROGIN of 89 Earl Street, Narrogin, Western Australia ("**the Lessor**")

AND

THE NARROGIN BOWLING CLUB INC. of 58 Earl Street, Narrogin, Western Australia ("**the Lessee**")

RECITAL

Subject to certain approvals and consents being obtained, the Lessor has agreed to lease the Premises to the Lessee and the Lessee has agreed to take the Premises on lease from the Lessor upon and subject to the provisions of this Lease.

OPERATIVE PROVISIONS

1. INTERPRETATION

1.1 Definitions

In this document:

"**Premises**" means the land described in item 1 of the Schedule together with all buildings and improvements on that land or after the signing of this Lease erected on that land and includes any part thereof;

"**Reserve**" means where the Premises are a reserve or portion of a reserve vested in the Lessor under and by virtue of the provisions of section 33 of the Land Act 1933, that reserve;

"**Term**" means the term specified in item 4 of the Schedule and includes, if the Lessee exercises any option of renewal of this Lease granted to the Lessee pursuant to the provisions of **clause 3.2**, any further term.

1.2 Construction

Unless expressed to the contrary:

(a) words importing:

(i) the singular include the plural and vice versa;

(ii) any gender include the other genders;

(b) if a word or phrase is defined cognate words and phrases have corresponding definitions;

(c) a reference to:

(i) a person includes a firm, unincorporated association, corporation and a government or statutory body or authority;

- (ii) a person includes its legal personal representatives, successors and assigns;
- (iii) a statute, ordinance, code or other law includes regulations and other statutory instruments under it and consolidations, amendments, re-enactments or replacements of any of them;
- (iv) a right includes a benefit, remedy, discretion, authority or power;
- (v) an obligation includes a warranty or representation and a reference to a failure to observe or perform an obligation includes a breach of warranty or representation;
- (vi) provisions or terms of this document or another document, agreement, understanding or arrangement include a reference to both express and implied provisions and terms;
- (vii) time is to local time in Perth, Western Australia;
- (viii) "\$" or "dollars" is a reference to the lawful currency of Australia;
- (ix) this or any other document includes the document as varied or replaced and notwithstanding any change in the identity of the parties;
- (x) writing includes any mode of representing or reproducing words in tangible and permanently visible form, and includes facsimile transmissions.

1.3 Headings

Headings do not affect the interpretation of this document.

1.4 Exercise of Discretion

A power, authority, right or discretion conferred by this Lease may be exercised from time to time as the occasion requires.

1.5 Withholding of Consent or Approval

Where the consent or approval of a party to this Lease is required, that consent or approval must not be unreasonably or capriciously withheld, but this clause has no application to clause 4.5.

2. CONDITIONS

2.1 Conditions

This Lease is subject to and conditional upon:

- (a) the approval in writing of the Minister for Lands under the Land Act 1933;
- (b) the approval of the State Planning Commission under section 20 of the Town Planning and Development Act 1928; and

(c) any other necessary approvals and consents,

(if and to the extent that those approvals and consents are necessary and have not been obtained prior to the signing of this Lease) being obtained within three months after the signing of this Lease.

2.2 Application for Approvals and Consents

As soon as possible after the signing of this Lease the Lessor must make application for the approvals and consents referred to in **clause 2.1** and must pursue those applications and the Lessee must promptly join in the applications as may be necessary.

2.3 Failure of Condition

If any approval or consent is refused or not obtained on or prior to the date specified in **clause 2.1** this document ceases to have effect and no party has any claim against any other party.

2.4 Approval or Consent Subject to Conditions

If any approval or consent is granted subject to any conditions with which either party is unable or reasonably unwilling to comply that party may give to the other a notice in writing that the condition is unacceptable and thereupon the approval or consent is deemed to have been refused and this document ceases to have effect and no party has any claim against any other party.

3. LEASE

3.1 Initial Term

The Lessor leases the Premises to the Lessee and the Lessee takes the Premises on lease from the Lessor together with the rights specified in item 2 of the Schedule but subject to the reservations specified in item 3 of the Schedule for the term specified in item 4 of the Schedule at the rental specified in item 5 of the Schedule upon and subject to the provisions of this Lease.

3.2 Option of Renewal

If at the date of exercise of the option in this **clause 3.2** contained the Lessee has not failed to comply with any notice given by the Lessor to the Lessee requiring the Lessee to remedy a breach by the Lessee of the provisions of this Lease on the Lessee's part to be complied with, the Lessee has the option of extending this Lease for the further term specified in item 6 of the Schedule exercisable by the written request of the Lessee made not more than six (6) months nor less than three (3) months prior to the expiration of the term specified in item 4 of the Schedule at the same rental and upon the same provisions as are contained in this Lease except this **clause 3.2**.

4. LESSEE'S AGREEMENTS WITH LESSOR

The Lessee agrees with the Lessor as follows:

4.1 Rent

To pay to the Lessor the rent in the manner specified in item 5 of the Schedule without any deduction or abatement whatsoever except if the Premises are destroyed or damaged as set out in **clause 7**.

4.2 Rates and Taxes

Duly and punctually to pay all rates, taxes, assessments, impositions and outgoings of whatsoever nature payable or hereafter to become payable to any Government, local or other authority in respect of the Premises including but without limiting the generality of the foregoing rates and other charges assessed on the Premises or the occupier of the Premises by the Lessor and the following applies:

- (a) The Lessee's liability in respect of all such rates, taxes, assessments, impositions and outgoings commences on the date of commencement of the Term and ceases on the expiration of the Term and must be apportioned between the parties on each of those dates;
- (b) in the event that the Premises are not separately rated, charged or assessed in respect of any of the rates, taxes, assessments, impositions and outgoings referred to in this **clause 4.2** then for the purposes of this **clause 4.2** they must be apportioned between the Premises and the other premises the subject of the assessment in proportion to their respective areas.

4.3 Rubbish Charges

Duly and punctually to pay all rubbish charges assessed on the Premises or the occupier of the Premises by the Lessor.

4.4 Electricity, and Gas, Telephone and Water

Duly and punctually to pay and discharge all charges and meter rents in respect of gas, electricity, water (including excess water) and telephone used, consumed or incurred on the Premises.

4.5 Assignment, Subletting, Parting with Possession

Not to assign, mortgage, charge, sublet or part with the possession of the Premises without the prior written consent of the Lessor and if and to the extent that such approval is necessary, the prior approval in writing of the Minister for Lands which consents and approvals the Lessor and the Minister for Lands may in their absolute discretion refuse without assigning any reason and it is agreed that Sections 80 and 82 of the Property Law Act 1969 are excluded from and do not apply to this Lease.

4.6 Statutory Obligations

To comply with and obey the provisions of and all lawful and valid regulations, notices, orders and by-laws which may from time to time be made or given with respect to or affecting the Premises or the use or occupancy of the Premises under the provisions of the Health Act 1911, the Local Government Act 1995, the Metropolitan Water Supply Sewerage & Drainage Act 1909, the Fire Brigades Act 1942, the Bush Fires Act 1954, the Environmental Protection Act 1986 or any other statute, order, regulation, by-law, local law

or town planning scheme now or hereafter in force or made or given by any Minister, Department, Health Board, Local Government, Water Board or other competent authority or person.

4.7 Alterations

Not without the prior written consent of the Lessor to erect or suffer to be erected any building or structure on the Premises or to make or suffer to be made any alteration in or to any building or structure erected on the Premises or cut, maim or injure or suffer to be cut, maimed or injured any of the walls or timbers of such building or structure and that if any buildings and improvements are to be constructed, erected or made or works carried out or executed on the Premises by the Lessee, it is agreed that they must be constructed, erected, made, carried out and executed under the supervision and to the satisfaction of the Lessor and not otherwise.

4.8 Cleaning, Maintenance and Repair

To:

- (a) keep and maintain the Premises in good and tenable repair and condition and clean and in good order and to renew all worn or broken parts of the Premises;
- (b) keep and maintain the Premises clean and tidy and free from dirt and rubbish;
- (c) cut, water and maintain properly all lawns and hedges from time to time planted on the Premises and to water and maintain properly all gardens, trees, shrubs and other flora from time to time laid out or planted on the Premises and where necessary to replace all shrubs and plants that die or are destroyed;
- (d) keep and maintain the portion of the Reserve surrounding the Premises clean and tidy and free of all rubbish; and
- (e) take all reasonable precautions to keep the Premises free of rodents, vermin, insects, termites and other pests and in the event of failing to do so must if so required by the Lessor but at the cost of the Lessee employ from time to time or periodically pest exterminators approved by the Lessor.

4.9 Use

Not to:

- (a) use or to permit to be used the Leased Premises for any purpose whatsoever other than for the purposes and objects for which the Reserve was vested in and is held by the Lessor;
- (b) use or permit to be used the Leased Premises for any purpose other than that or those specified in item 7 of the Schedule;
- (c) carry on or suffer to be carried on upon the Premises any noxious noisome or offensive trade act business occupation or calling;

- (d) make, do or suffer upon the Premises any act, matter or thing that may be or become a nuisance or annoyance to the Lessor or to the owners or occupiers of property in the neighbourhood of the Premises;
- (e) sell or dispense alcohol from the Premises or allow alcohol to be sold or dispensed from the Premises other than in accordance with the provisions of the Liquor Licensing Act, 1988;
- (f) cut down any trees, plants or shrubs or sell, remove or otherwise dispose of any clay, sand, gravel, timber or other materials from the Premises; or
- (g) store chemicals, inflammable liquids, acetylene gas or volatile or explosive oils, compounds or substances upon the Premises other than motor fuels, fertilisers and other substances reasonably required for conducting the normal activities of the Lessee which are permitted pursuant to **clause 4.9(b)**.

4.10 Signs

Not to affix or exhibit or permit to be affixed or exhibited to or upon the Premises any placard, poster, sign, board or other advertisement without the prior written consent of the Lessor.

4.11 Insurance

To take out and keep in force the following policies of insurance with an insurance office approved by the Lessor:

- (a) a building and industrial special risk policy in the joint names of the Lessor and the Lessee to cover the Premises and all plate glass installed on the Premises against loss or damage by fire, fusion, explosion, smoke, lightning, flood, storm, tempest, rain, water, water damage, leakage, earthquake, riot, civil commotion, malicious damage, impact by vehicles, aircraft and articles dropped therefrom and any other risks required by the Lessor, such cover not to be less than the full insurable value of the Premises and plate glass on a replacement and/or reinstatement basis;
- (b) a public liability insurance policy naming the Lessee as the insured for an amount which at the commencement of the Term must not be less than the sum of FIVE MILLION DOLLARS (\$5,000,000.00) and which must be adjusted at the expiration of the first and each succeeding year during the Term to an amount which on the date of each adjustment the parties agree represents an amount of public risk insurance which a reasonable and prudent person in the circumstances of the Lessee would take out and in the event of any dispute concerning the amount it must be fixed at the expense of the Lessee by an insurance broker nominated by the Lessor;
- (c) the usual workers' compensation policy covering all employees of the Lessee; and
- (d) a contractor's risk insurance policy in such amount as the Lessor may require to cover the whole of any works from time to time carried out by the Lessee on the Premises

and to deposit a photocopy of each such policy of insurance with the Lessor and at least seven (7) days before they become due to pay all premiums necessary for that purpose and deposit with the Lessor a photocopy of the receipt for the current year's premium or a certificate of renewal of the insurance company and if the Lessee at any time fails to insure and keep insured as above it is agreed the Lessor may do all things necessary to effect or maintain the insurance and that the Lessee must repay any moneys expended by the Lessor for that purpose on demand and any moneys so expended are deemed to be rent in arrears and may be recovered by the Lessor accordingly.

4.12 Lessor's Rights of Entry

To permit:

- (a) the Lessor, any employee of the Lessor and any other person authorised by the Lessor at all reasonable times to enter upon the Premises and view the condition of the Premises and upon notice being given by the Lessor, to repair the Premises in accordance with such requirements as are set out in any such notice;
- (b) the Lessor, any employee of the Lessor and any other person authorised by the Lessor, with all necessary vehicles plant and materials at all times to have access to the Premises and the right to remain on the Premises to carry out any building, alterations, improvements or works whether structural or otherwise which the Lessor desires or is required to effect upon the Premises.

4.13 Costs

To pay:

- (a) all costs of and incidental to the preparation, execution and stamping of this Lease; and
- (b) all costs, charges and expenses (including solicitors' costs) incurred by the Lessor for the purposes of or incidental to the preparation and service of a notice under Section 81 of the Property Law Act, 1969, requiring the Lessee to remedy a breach of any provision of this Lease notwithstanding forfeiture for the breach is avoided otherwise than by relief granted by the Court.

4.14 Indemnity

- (a) To the extent that the terms and conditions of any insurance effected by the Lessor or any money paid to the Lessor out of insurance effected by the Lessee do not fully indemnify the Lessor against all actions, claims, demands, notices, losses, damages, costs and expenses to which the Lessor becomes liable in respect of any of the matters referred to in sub-paragraphs (i), (ii) and (iii) of this **clause 4.14(a)**, to indemnify and keep indemnified the Lessor against all actions, claims, demands, notices, losses, damages, costs and expenses for which the Lessor becomes liable in respect of any loss or damage to property or death or injury of whatever nature or kind and however and wherever sustained:
 - (i) caused or contributed to by the use or occupation of the Premises except to the extent that the same is caused or contributed to by the negligence, act, default or omission of the Lessor;

- (ii) resulting from any negligence, act, default or omission of the Lessee; or
 - (iii) resulting from any notice, claim or demand to pay, do or perform any act, matter or thing to be paid, done or performed by the Lessee under this Lease except to the extent that the Lessor is obliged under the provisions of this Lease to pay for or contribute to that cost.
- (b) Without limiting the generality of **clause 4.14(a)**, to indemnify and keep indemnified the Lessor against all actions, claims, demands, losses, damages, costs and expenses for which the Lessor becomes liable in respect of or arising from the overflow or leakage of water or other fluids in or from the Premises except to the extent that the same is caused or contributed to by the negligence, act, default or omission of the Lessor.
 - (c) Without limiting the generality of **clauses 4.14(a) and 4.14(b)**, to indemnify and keep indemnified the Lessor against any claim, action, demand, fine, damage, costs or expenses arising out of any breach by the Lessee or its servants, agents, contractors, customers, invitees of any provision of the Occupational Health, Safety and Welfare Act 1984.

5. LESSOR'S AGREEMENT WITH LESSEE: QUIET ENJOYMENT

The Lessor agrees with the Lessee that if the Lessee pays the Rent and observes and performs the provisions of this Lease on the part of the Lessee to be observed and performed, the Lessee is, subject to **clause 4.12**, entitled to peaceably hold and enjoy the Premises during the Term without any interruption by the Lessor or any person rightfully claiming under or in trust for the Lessor.

6. DEFAULT

The Lessor and the Lessee agree as follows:

6.1 Default: Essential Terms

Each of the obligations of the Lessee set out in **clauses 4.1** (payment of rent), **4.2** (payment of rates and taxes), **4.5** (assignment, sub-letting and parting with possession), **4.8** (cleaning, maintenance and repair), **4.9** (use of the Premises), **4.11** (the Lessee's insurances) and **4.14** (indemnity) of this Lease is an essential term of this Lease.

6.2 Default

If:

- (a) any rent or any other moneys payable under this Lease remain unpaid for fourteen (14) days after written demand has been received by the Lessee from the Lessor; or
- (b) an order is made or a resolution is effectively passed for the winding up of the Lessee (other than for the purpose of amalgamation or reconstruction) or the Lessee becomes bankrupt or if any deed of assignment or deed of arrangement is prepared by or for or presented to the Lessee for execution by it or there is appointed under any Act or instrument or by order of any Court a manager or an administrator or a

trustee or a receiver or a receiver and manager or liquidator in relation to any part of the Lessee's undertakings or assets or property; or

- (c) the Lessee fails within the time specified in a notice (which time shall be not less than seven (7) days) requiring the Lessee to remedy a breach by the Lessee of any one or more of the provisions of this Lease unless the non-performance or non-observance has been waived or excused by the Lessor in writing; or
- (d) the Premises are deserted or vacated,

then and in each case the Lessor or any person or persons duly authorised by the Lessor at any time thereafter and without any notice or demand may re-enter into and upon the Premises and repossess the Premises and thereby the Term and the estate and interest of the Lessee in the Premises will immediately determine.

The Lessor's right of action referred to above is without prejudice to the right of action or other remedy which the Lessor has in respect of any prior breach by the Lessee of any provision of this Lease and following such forfeiture the Lessor is entitled to recover from the Lessee damages for loss of the benefits which performance of the provisions of this Lease by the Lessee would have conferred on the Lessor between the date of forfeiture and the expiry of this Lease by the effluxion of time.

6.3 Execution of Works by Lessor

If and whenever the Lessee fails within the time specified in a notice issued pursuant to **clause 6.2(c)** to remedy a breach of a provision of this Lease, the Lessor may (without prejudice to any other rights or remedies of the Lessor) enter upon the Premises, carry out or execute any repairs, requisitions, notices or works, remedy any default, pay or discharge any outgoing or other moneys or do any act, matter or thing the Lessor thinks necessary or desirable to ensure or secure compliance with the provisions of this Lease and the Lessee must repay any moneys expended by the Lessor for that purpose on demand and any moneys so expended are deemed to be rent in arrears and may be recovered by the Lessor accordingly.

6.4 Interest on Overdue Money

Without affecting the rights, powers and remedies of the Lessor under this Lease, the Lessee agrees to pay to the Lessor on demand interest on any money due by the Lessee to the Lessor pursuant to this Lease but unpaid for seven (7) days calculated from the due date for payment until payment in full and computed at the rate per cent per annum which is from time to time 2% above the prime rate of interest (expressed as a rate per cent per annum) charged by the Lessor's bankers on loans of less than \$100,000.00 from time to time and such interest is deemed to be rent in arrears and may be recovered by the Lessor accordingly.

6.5 Acceptance of Rent Not to Prejudice Lessor's Right

Demand for or acceptance of rent or any other amounts payable by the Lessee in terms of this Lease after default by the Lessee under this Lease (other than on the grounds of non-payment of that rent or the other amounts as the case may be) will not affect the exercise by the Lessor of the rights and powers conferred upon the Lessor by this Lease and will not operate as an election by the Lessor to exercise or not to exercise any right or power.

7. DAMAGE OR DESTRUCTION

7.1 Damage or Destruction

- (a) Subject to the provisions of **clause 7.2** if the Premises are at any time during the Term totally or partially destroyed or damaged so as to render the Premises unfit for the occupation and use of the Lessee or inaccessible, the rent and any other moneys payable by the Lessee under the terms of this Lease ("the **Amounts Payable**") or a proportionate part of the Amounts Payable according to the nature and extent of the damage sustained shall abate and all or any remedies for recovery of the Amounts Payable falling due after the destruction or damage or a proportionate part of the Amounts Payable shall be suspended until the Premises have been rebuilt or made fit for the occupation and use of the Lessee or accessible to the Lessee as the case may be.
- (b) The abatement of the Amounts Payable referred to above shall not apply in case of destruction or damage caused by the Lessee or if any policy or policies of insurance have been vitiated or payment of the policy moneys refused because of the act, default or omission of the Lessee or of any servant, agent, invitee or licensee of the Lessee.
- (c) If there is any dispute between the parties concerning the interpretation of this **clause 7.1** that dispute must be referred to the award of a single arbitrator (who must conduct the arbitration in accordance with the provisions of the Commercial Arbitration Act 1985) to be appointed in default of agreement between the parties by the President for the time being of the Australian Institute of Valuers and Land Economists (Inc.) WA Division, at the request of either the Lessor or the Lessee, whose appointment is final and the Lessee must pay the Amounts Payable without any deduction or abatement until the date of the award of the arbitrator whereupon the Lessor must refund any of the Amounts Payable which according to the award has been overpaid. Each party is entitled to legal representation at any such arbitration.

7.2 Total Damage or Destruction

If the Premises are at any time during the Term destroyed or damaged to an extent as to be wholly unfit for occupation and use either party may by notice in writing to the other of them given within twenty eight (28) days after the event determine this Lease and thereupon this Lease is determined without prejudice however to the liability of the Lessee under this Lease up to the date of determination.

8. MISCELLANEOUS PROVISIONS

The Lessor and the Lessee agree that:

8.1 Notices

Any notice to be given pursuant to this Lease is deemed to have been duly served on the party to whom it is to be given if served in the manner provided in Section 135 of the Property Law Act, 1969 and, in addition, in the case of a notice to the Lessee if left addressed to the Lessee at the Premises.

8.2 Holding Over

If the Lessee remains in possession of the Premises after the expiry of the Term with the consent of the Lessor the Lessee will be a monthly tenant of the Lessor at a monthly rent equivalent to one twelfth of the aggregate of the rent payable upon the expiry of the Term which would be payable by the Lessee if an extension of the Term had been granted at the expiry of the Term and otherwise on the same terms and conditions as this Lease (except clause 3.2).

8.3 Waiver

No waiver by the Lessor of any breach of any provision of this Lease by the Lessee operates as a waiver of another breach of any provision of this Lease by the Lessee.

8.4 Severance

If any part of this Lease is or becomes void or unenforceable then that part is or will be severed from this Lease so that all parts not void or unenforceable remain in full force and effect and unaffected by that severance.

8.5 Statutory Powers

The powers conferred by or under any statute (except to the extent inconsistent with the terms and provisions expressed in this Lease) are in augmentation of the powers conferred on the Lessor by this Lease.

8.6 Governing Law and Jurisdiction

- (a) This document is governed by and is to be construed in accordance with the laws in force in Western Australia.
- (b) Each party irrevocably and unconditionally submits to the non-exclusive jurisdiction of the courts of Western Australia and any courts which have jurisdiction to hear appeals from any of those courts and waives any right to object to any proceedings being brought in those courts.

8.7 Joint and Several Liability

An obligation of two or more persons binds them jointly and severally.

8.8 Time of the Essence

Time is of the essence in respect of the performance and observance by the Lessee of the provisions of this Lease.

9. LIMITATION OF LIABILITY OF LESSOR

The Lessor's obligations under this Lease:

- (a) bind only the person holding the reversionary estate of the Premises immediately expectant upon the expiry of the Term; and

- (b) only render the Lessor liable in damages when the act omission or default giving rise to damages occurs while the Lessor is the registered proprietor of the Premises or while the Premises are vested in the Lessor (as the case may be).

SCHEDULE

1. Premises (Clauses 1.1 and 3.1)

Portion of Reserve No. 27330 (Narrogin Lot No. 1561) delineated and coloured green as shown at page 14 of this document

2. Rights (Clause 3.1)

Nil

3. Reservations (Clause 3.1)

Nil

4. Term (Clause 3.1)

Twenty one (21) years commencing 1st July 1997

5. Rent (Clauses 3.1 and 4.1)

One dollar (\$1.00) per annum

6. Further Term (Clause 3.2)

Twenty one years

7. Purpose for which Leased Premises to be Used (Clause 4.9(b))

Bowling Club

EXECUTED as an agreement.

THE COMMON SEAL of TOWN OF)
NARROGIN was hereunto affixed by)
authority of a resolution of the Council)
in the presence of:



[Signature] Mayor
Robert William Maxwell

[Signature] Chief Executive Officer
Stephen David Tindale

THE COMMON SEAL of THE)
NARROGIN BOWLING CLUB INC.)
was hereunto affixed by authority of a)
resolution of the Club in the presence of:)

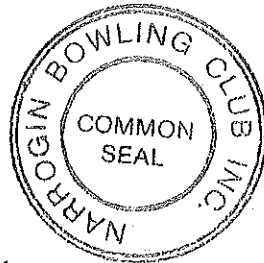

[Signature] President
Peter Harold Hansen

[Signature] Vice-President
George Rhys Davies

[Signature] Treasurer
Noel Dempster Grieve

(cp/gsbclsebowl)

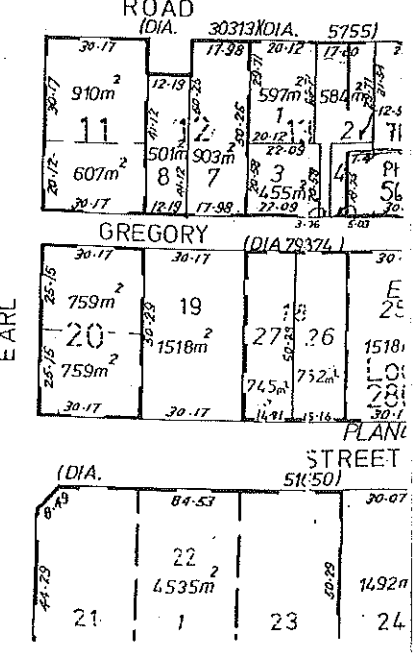
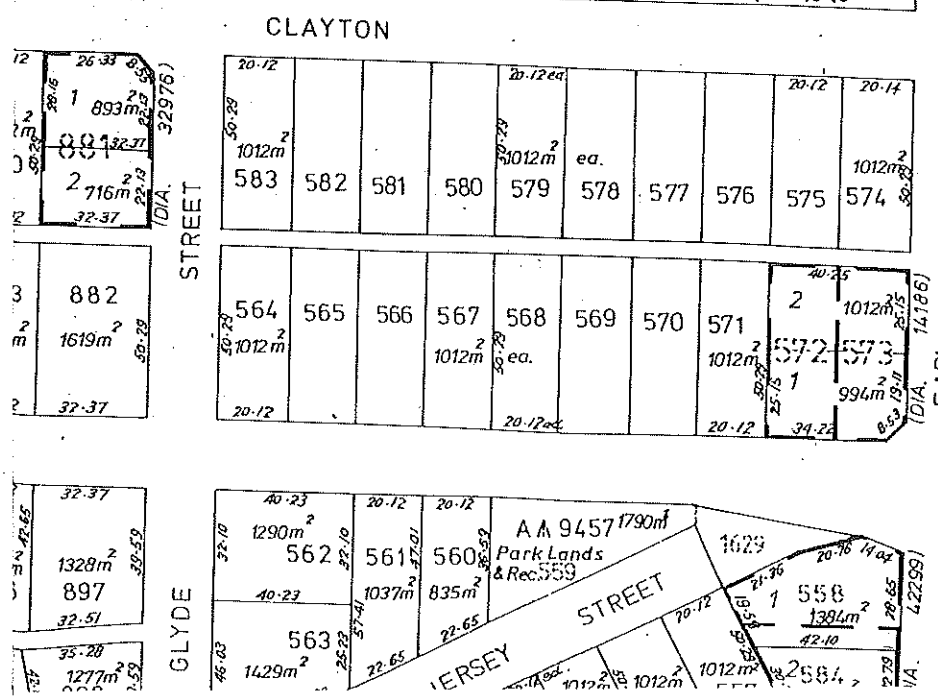
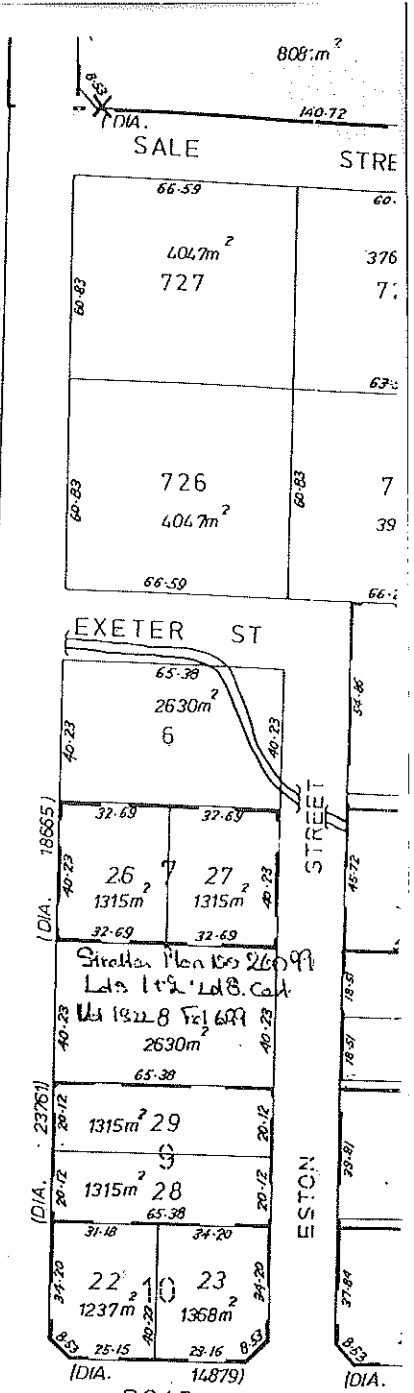
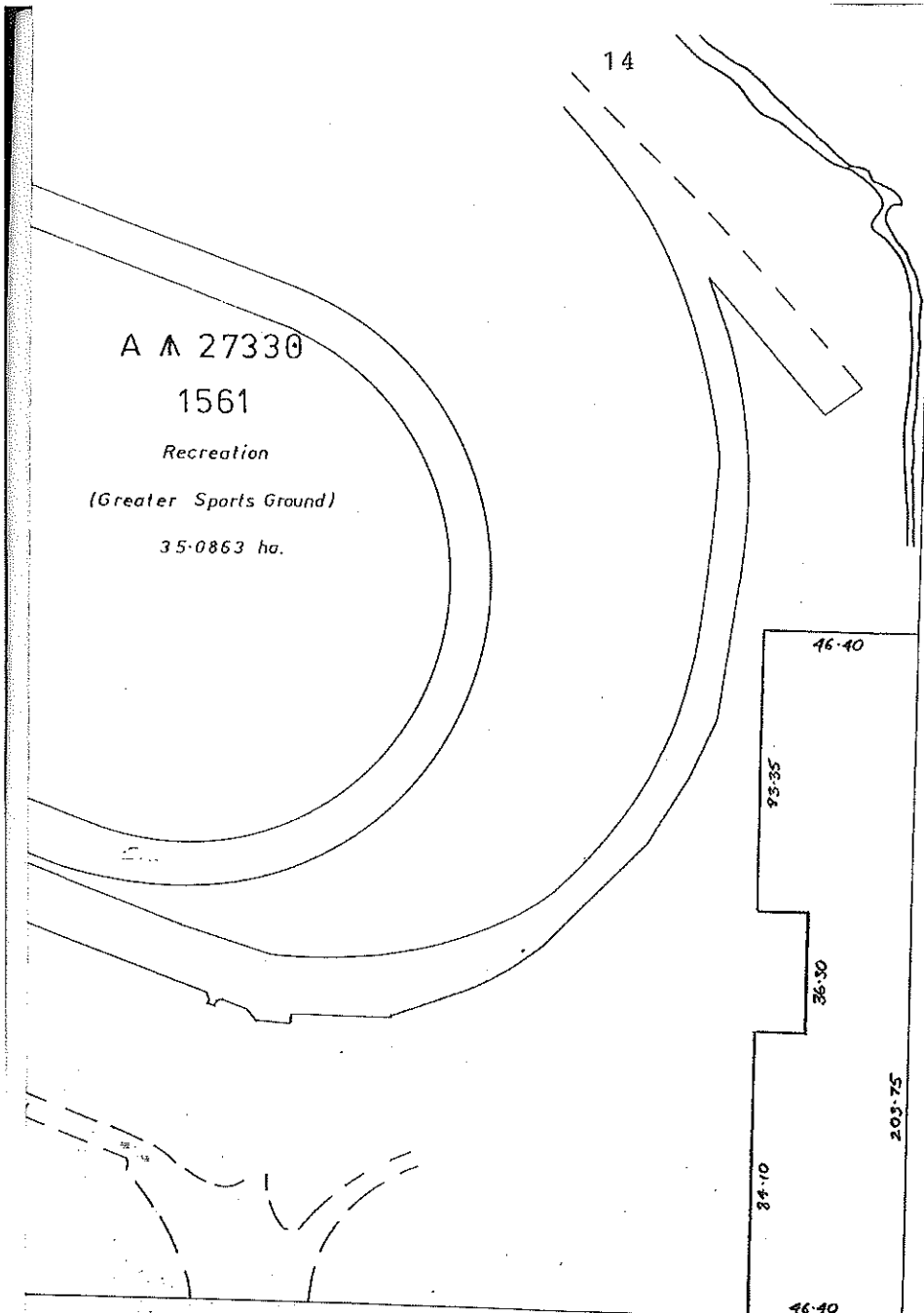

TOWN OF NARROGIN

AND

NARROGIN CROQUET CLUB INC

LEASE

**NARROGIN LOT 1561
NARROGIN CROQUET CLUBROOMS**

75
0/5/20

THIS LEASE is made on 1 June 2001.

BETWEEN TOWN OF NARROGIN of 89 Earl Street, Narrogin, Western Australia ("Lessor")

AND NARROGIN CRQUET CLUB INC. ("Lessee")

RECITAL

Subject to certain approvals and consents being obtained, the Lessor has agreed to lease the Premises to the Lessee and the Lessee has agreed to take the Premises on lease from the Lessor upon and subject to the provisions of this Lease.

IT IS AGREED

1. INTERPRETATION

1.1 Definitions

In this document:

"Commencement Date " means the Commencement Date specified in Item 4 of the Schedule.

"Expiration Date " means the Expiration Date specified in Item 4 of the Schedule.

"Permitted Use " means the Permitted Use specified in Item 8 of the Schedule.

"Premises" means the land described in item 1 of the Schedule together with all buildings and improvements on that land or after the signing of this Lease erected on that land and includes any part thereof.

"Rent " means the rent specified in the Schedule and the rent payable under this Lease from time to time.

"Reserve" means where the Premises are a reserve (as defined in the Land Administration Act 1997) or portion of such a reserve which has been placed under the care, control and management of the Lessor pursuant to the Land Administration Act 1997, that reserve.

"Term" means the term specified in item 4 of the Schedule and includes, if the Lessee exercises any option of renewal of this Lease granted to the Lessee pursuant to the provisions of clause 3.2, any further term.

1.2 Definitions: GST

In this document the expressions "consideration", "GST", "input tax credit", "supplier", "supply", "tax invoice", "recipient" and "taxable supply" have the meanings given to those expressions in the A New Tax System (Goods and Services Tax) Act 1999.

1.3 Construction

Unless expressed to the contrary:

- (a) words importing:
 - (i) the singular include the plural and vice versa;

- (ii) any gender include the other genders;
- (b) if a word or phrase is defined cognate words and phrases have corresponding definitions;
- (c) a reference to:
 - (i) a person includes a firm, unincorporated association, corporation and a government or statutory body or authority;
 - (ii) a person includes its legal personal representatives, successors and assigns;
 - (iii) a statute, ordinance, code or other law includes regulations and other statutory instruments under it and consolidations, amendments, re-enactments or replacements of any of them;
 - (iv) a right includes a benefit, remedy, discretion, authority or power;
 - (v) an obligation includes a warranty or representation and a reference to a failure to observe or perform an obligation includes a breach of warranty or representation;
 - (vi) provisions or terms of this document or another document, agreement, understanding or arrangement include a reference to both express and implied provisions and terms;
 - (vii) time is to local time in Perth, Western Australia;
 - (viii) "\$" or "dollars" is a reference to the lawful currency of Australia;
 - (ix) this or any other document includes the document as varied or replaced and notwithstanding any change in the identity of the parties;
 - (x) writing includes any mode of representing or reproducing words in tangible and permanently visible form, and includes facsimile transmissions.

4.4 Headings

Headings do not affect the interpretation of this document.

4.5 Exercise of Discretion

A power, authority, right or discretion conferred by this Lease may be exercised from time to time as the occasion requires.

4.6 Withholding of Consent or Approval

Where the consent or approval of a party to this Lease is required, that consent or approval must not be unreasonably or capriciously withheld, but this clause has no application to **clause 4.5**.

2. CONDITIONS

2.1 Conditions

This document is subject to and conditional upon:

- (a) the prior approval in writing of the Minister for Lands pursuant to section 18 of the Land Administration Act 1997; and
- (b) any other necessary approvals and consents (if and to the extent that those approvals and consents are necessary and have not been obtained prior to the signing of this document) being obtained within three months after the signing of this document.

2.2 Application for Approvals and Consents

As soon as possible after the signing of this document the Lessor must, if the Lessor has not already done so, make application for the approvals and consents referred to in **clause 2.1(b)** and must pursue those applications and the Lessee must promptly join in the applications as may be necessary.

2.3 Failure of Condition

If any approval or consent is refused or not obtained on or prior to the date specified in **clause 2.1(b)** this document ceases to have effect and no party has any claim against any other party.

2.4 Approval or Consent Subject to Conditions

If any approval or consent is granted subject to any conditions with which either party is unable or reasonably unwilling to comply that party may give to the other a notice in writing within one month of becoming aware of the condition that the condition is unacceptable and thereupon the approval or consent is deemed to have been refused and this document ceases to have effect and no party has any claim against any other party.

3. LEASE

3.1 Initial Term

The Lessor leases the Premises to the Lessee and the Lessee takes the Premises on lease from the Lessor together with the rights specified in item 2 of the Schedule but subject to the reservations specified in item 3 of the Schedule for the term specified in item 4 of the Schedule at the Rent specified in item 5 of the Schedule upon and subject to the provisions of this Lease.

3.2 Option of Renewal

If at the date of exercise of the option the Lessee has not failed to comply with any notice given by the Lessor to the Lessee requiring the Lessee to remedy a breach by the Lessee of the provisions of this Lease on the Lessee's part to be complied with, the Lessee has the option of extending this Lease for the Further Term specified in item 6 of the Schedule exercisable by the written request of the Lessee made not more than six (6) months nor less than three (3) months prior to the expiration of the term specified in item 4 of the Schedule at the same rental and upon the same provisions as are contained in this Lease except this **clause 3.2**.

1. LESSEE'S AGREEMENTS WITH LESSOR

The Lessee agrees with the Lessor as follows:

4.1 Rent

To pay to the Lessor the Rent in the manner specified in item 5 of the Schedule without any deduction or abatement whatsoever except if the Premises are destroyed or damaged as set out in **clause 7**.

4.2 Outgoings

Duly and punctually to pay all rates, taxes, assessments, charges, impositions and outgoings of whatsoever nature payable or hereafter to be become payable to any Government, local government or other authority in respect of the Premises and the following applies:

- (a) the Lessee's liability in respect of all such rates, taxes, assessments, charges, impositions and outgoings commences on the Commencement Date and ceases on the Expiration Date and must be apportioned between the parties on each of those dates;
- (b) if the Premises are not separately rated, charged or assessed in respect of any of the rates, taxes, assessments, charges, impositions and outgoings referred to in this **clause 4.2(a)** then for the purposes of this **clause 4.2** they must be apportioned between the Premises and the other premises the subject of the assessment in proportion to their respective areas.

4.3 Rubbish Charges

Duly and punctually to pay all rubbish charges assessed on the Premises or the occupier of the Premises by the Lessor.

4.4 Electricity, and Gas, Telephone and Water

Duly and punctually to pay and discharge all charges and meter rents in respect of gas, electricity, water and telephone used, consumed or incurred on the Premises and if it is possible and reasonably practical to do so, to procure the issue of accounts in respect of such services to and in the name of the Lessee rather than to and in the name of the Lessor.

4.5 Assignment, Subletting, Parting with Possession

- (a) Not to assign, mortgage, charge, sublet or part with the possession of the Premises without the prior written consent of the Lessor which consent the Lessor may in the Lessor's absolute discretion refuse without assigning any reason and it is agreed that Sections 80 and 82 of the Property Law Act 1969 are excluded from and do not apply to this Lease.
- (b) Not to assign, mortgage, charge, sub-let or part with the possession of the Premises without such prior approval in writing of the Minister for Lands if his consent is required pursuant to the Land Administration Act 1997.

4.6 Statutory Obligations

- (a) To comply with and obey the provisions of and all lawful and valid regulations, notices, orders and by-laws which may from time to time be made or given with respect to or affecting the Premises or the use or occupancy of the Premises under the provisions of the Health Act 1911, the Local Government Act 1995, the Metropolitan Water Supply Sewerage & Drainage Act 1909, the Fire Brigades Act 1942, the Bush Fires Act 1954, the Environmental Protection Act 1986 or any other statute, order, regulation, by-law or town planning scheme now or hereafter in force or made or given by any Minister, Department, Health Board, Municipal Council, Water Board or other competent authority or person.
- (b) To take out and keep current any lease required in connection with any activities carried on from the Premises.

4.7 Alterations

Not without the prior written consent of the Lessor to:

- (a) erect or suffer to be erected any building or structure on the Premises or to make or suffer to be made any alteration in or to any building or structure erected on the Premises or cut, maim or injure or suffer to be cut, maimed or injured any of the walls or timbers of such building or structure; and
- (b) install any water, gas or electrical fixtures, equipment, appliance or apparatus for illuminating air conditioning, heating cooling or ventilating the Premises

and that if any buildings and improvements are to be constructed, erected or made or works carried out or executed on the Premises or any such installation is to be made by the Lessee, it is agreed that they must be constructed, erected, made, carried out and executed under the supervision and to the satisfaction of the Lessor and not otherwise.

4.8 Cleaning, Maintenance and Repair

To:

- (a) keep and maintain the Premises (including, without limitation, all lighting and electrical installations, all fences and gates and all reticulation and drainage systems) in good and tenable repair and condition to a standard acceptable to the Lessor, fair wear and tear excepted;
- (b) without limiting the generality of paragraph (a), keep and maintain all:
 - (i) Windows and doors clean, operable and lockable;
 - (ii) Showers, sinks and basins clean and free from blockages; and
 - (iii) Hot water services, stoves, airconditioning units and plant, refrigerators, fans and heaters clean and regularly maintained in accordance with the manufacturer's specification and any relevant Australian standards;

- (c) remove graffiti from any building on the Premises as soon as possible but in any event no later than 24 hours after the presence of that graffiti is identified;
- (d) keep and maintain the Premises clean and tidy and free from dirt and rubbish;
- (e) cut, water and maintain properly all lawns and hedges from time to time planted on the Premises and to water and maintain properly all gardens, trees, shrubs and other flora from time to time laid out or planted on the Premises and where necessary to replace all shrubs and plants that die or are destroyed;
- (f) Keep and maintained the portion of the Reserve surrounding the Premises clean and tidy and free of all rubbish; and
- (g) Take all reasonable precautions to keep the Premises free of rodents, vermin, insects, termites and other pests and in the event of failing to do so must if so required by the Lessor but at the cost of the Lessee employ from time to time or periodically pest exterminators approved by the Lessor.

4.9 Painting

With the frequency specified in item 7 of the Schedule:

- (a) to paint with two (2) coats, undercoat and finishing coat, at least of first quality exterior paint and to oil with two (2) coats at least of first quality oil in a proper and workmanlike manner to the satisfaction of the Lessor all parts of the outside wood, iron, metal, stucco and cement work and all other external surfaces of all buildings on the Premises as are usually painted or oiled respectively; and
- (b) to paint or oil respectively with two (2) coats of interior paint or oil respectively in like manner all the internal wood and metal work and all other internal surfaces (including ceilings and walls) of such buildings and after every internal painting to grain, varnish, distemper, wash, stop, whiten and colour all parts as have previously been or are in the opinion of the Lessor required to be so dealt with first quality materials

but the Lessor may if in its opinion the condition of the buildings justify it relax these requirements as determined by it from time to time.

4.10 Use

Not to:

- (a) use or permit to be used the Premises for any purpose other than the Permitted Use;
- (b) carry on or suffer to be carried on upon the Premises any noxious noisome or offensive trade act business occupation or calling;
- (c) make, do or suffer upon the Premises any act, matter or thing that may be or become a nuisance or annoyance to the Lessor or to the owners or occupiers of property in the neighbourhood of the Premises;

- (d) sell or dispense alcohol from the Premises or allow alcohol to be sold or dispensed from the Premises other than in accordance with the provisions of the Liquor Licensing Act, 1988;
- (e) cut down any trees, plants or shrubs or sell, remove or otherwise dispose of any clay, sand, gravel, timber or other materials from the Premises;
- (f) store chemicals, inflammable liquids, acetylene gas or volatile or explosive oils, compounds or substances upon the Premises other than motor fuels, fertilisers (which must be stored separately from each other) and other substances reasonably required for conducting the normal activities of the Lessee which are permitted pursuant to **clause 4.10(b)**;
- (g) permit any person to sleep on the Premises; or
- (h) use or permit or suffer to be used any lavatories, toilets, sinks and drainage and other plumbing facilities in the Premises for any purposes other than those for which they were constructed or provided or deposit or permit to be deposited therein any sweepings, rubbish or other matter and any damage thereto arising caused by misuse shall be made good by the Lessee forthwith and all damages occasioned thereby shall also be paid by the Lessee.

4.11 Signs

Not to affix or exhibit or permit to be affixed or exhibited to or upon the Premises any placard, poster, sign, board or other advertisement without the prior written consent of the Lessor and if such consent is given, to keep and maintain any such advertisement in good and tenantable repair and condition.

4.12 Report Acts of Vandalism

To immediately report to the Lessor any acts of vandalism or any incident which occurs on or adjacent to the Premises which is or is likely to involve a breach of the peace or become the subject of a report to the police.

4.13 Insurance

1. To take out and keep in force the following policies of insurance with an insurer approved by the Lessor:
 - a) a public liability insurance policy naming the Lessee as the insured for an amount which at the commencement of the Term must not be less than the sum of TEN MILLION DOLLARS (\$10,000,000.00) and which must be adjusted at the expiration of the first and each succeeding year during the Term to an amount which on the date of each adjustment the parties agree represents an amount of public risk insurance which a reasonable and prudent person in the circumstances of the Lessee would take out and in the event of any dispute concerning the amount it must be fixed at the expense of the Lessee by an insurance broker nominated by the Lessor;

- b) the usual workers' compensation policy covering all employees of the Lessee; and
- c) such policies of insurance as are specified in item 9 of the Schedule

and to deposit each such policy of insurance with the Lessor and at least seven (7) days before they become due to pay all premiums necessary for that purpose and deposit with the Lessor the receipt for the current year's premium or a certificate of renewal of the insurance company and if the Lessee at any time fails to insure and keep insured as above it is agreed the Lessor may do all things necessary to effect or maintain the insurance and that the Lessee must repay any moneys expended by the Lessor for that purpose on demand and any moneys so expended are deemed to be rent in arrears and may be recovered by the Lessor accordingly.

2. Not to do or permit to be done anything whereby any policy of insurance in respect of the Premises may become void or voidable or by which the rate or premium on it may be increased and if any acts or defaults of the Lessee under this clause then to immediately pay the amount by which the premium shall be increased.
3. At the Lessee's own expense to make such amendments, alterations and additions to the Premises as shall be required by any requisitions or requirements of the Insurance Council of Australia or other body or authority having power or control over electrical installations or fixtures or dealing with insurance matters if the amendments, alterations and additions are required as a result of the Lessee's use of the Premises.

14 Insurance Premium: Lessor's Insurance

To pay to the Lessor upon demand:

- (a) such proportion of the insurance premium paid by the Lessor in taking out and keeping in force such policies of insurance as are specified in item 10 of the Schedule as the value of the Premises bears to the total value of the premises the subject of such policies of insurance, such values to be determined by the Lessor in its absolute discretion; and
- (b) any excess payable in respect of any claim made on any such policy of insurance.

15 Lessor's Rights of Entry

To permit:

- (a) the Lessor, any employee of the Lessor and any other person authorised by the Lessor at all reasonable times to enter upon the Premises and view the condition of the Premises and upon notice being given by the Lessor, to repair the Premises in accordance with such requirements as are set out in any such notice;
- (b) the Lessor, any employee of the Lessor and any other person authorised by the Lessor, with all necessary vehicles plant and materials at all times to have access to the Premises and the right to remain on the Premises to carry out any building, alterations, improvements or works whether structural or otherwise which the Lessor desires or is required to effect upon the Premises.

4.16 Costs

To pay:

- (a) all costs of and incidental to the preparation, execution and stamping of this Lease (including stamp duty); and
- (b) all costs, charges and expenses (including solicitors' costs and architects' fees) incurred by the Lessor for the purposes of or incidental to the preparation and service of a notice under Section 81 of the Property Law Act, 1969, requiring the Lessee to remedy a breach of any provision of this Lease notwithstanding forfeiture for the breach is avoided otherwise than by relief granted by the Court.

4.17 Indemnity

- (a) To the extent that the terms and conditions of any insurance effected by the Lessor or any money paid to the Lessor out of insurance effected by the Lessee do not fully indemnify the Lessor against all actions, claims, demands, notices, losses, damages, costs and expenses to which the Lessor becomes liable in respect of any of the matters referred to in sub-paragraphs (i), (ii) and (iii) of this **clause 4.17(a)**, to indemnify and keep indemnified the Lessor against all actions, claims, demands, notices, losses, damages, costs and expenses for which the Lessor becomes liable in respect of any loss or damage to property or death or injury of whatever nature or kind and however and wherever sustained:
 - (i) caused or contributed to by the use or occupation of the Premises except to the extent that the same is caused or contributed to by the negligence, act, default or omission of the Lessor;
 - (ii) resulting from any negligence, act, default or omission of the Lessee, its servants, agents, employees, contractors, customers or visitors; or
 - (iii) resulting from any notice, claim or demand to pay, do or perform any act, matter or thing to be paid, done or performed by the Lessee under this Lease except to the extent that the Lessor is obliged under the provisions of this Lease to pay for or contribute to that cost.
- (b) Without limiting the generality of **clause 4.17(a)**, to indemnify and keep indemnified the Lessor against all actions, claims, demands, losses, damages, costs and expenses for which the Lessor becomes liable in respect of or arising from the overflow or leakage of water or other fluids in or from the Premises except to the extent that the same is caused or contributed to by the negligence, act, default or omission of the Lessor.
- (c) Without limiting the generality of **clauses 4.17(a) and 4.17(b)**, to indemnify and keep indemnified the Lessor against any claim, action, demand, fine, damage, costs or expenses arising out of any breach by the Lessee or its servants, agents, contractors, customers, invitees of any provision of the Occupational Health, Safety and Welfare Act 1984.

4.18 Restore Premises

Upon the expiration or sooner determination of the Term to remove all fixtures and fittings of the Lessee from the Premises and to make good any damage caused by such removal and in particular but without limiting the generality of the above to remove or paint over, as the case may require, any sign, placard or advertisement affixed or exhibited in to or upon the Premises by the Lessee.

4.19 Deliver up Premises

Upon the expiration or sooner determination of the Term to deliver up the Premises and all additions to the Premises and fixtures and fittings in the Premises and the keys of the Premises (if any) to the Lessor in good and tenantable repair order and condition in strict accordance with the Lessee's obligations under this Lease.

LESSOR'S AGREEMENTS WITH LESSEE

The Lessor agrees with the Lessee as follows:

4.1 Quiet Enjoyment

If the Lessee pays the Rent and observes and performs the provisions of this Lease on the part of the Lessee to be observed and performed, the Lessee is, subject to **clause 4.15**, entitled to peaceably hold and enjoy the Premises during the Term without any interruption by the Lessor or any person rightfully claiming under or in trust for the Lessor.

4.2 Insurance

To take out and keep in force such policies of insurance as are specified in item 10 of the Schedule.

DEFAULT

The Lessor and the Lessee agree as follows:

4.1 Default: Essential Terms

Each of the obligations of the Lessee set out in **clauses 4.1** (payment of Rent) **4.2** (payment of outgoings), **4.5** (assignment, sub-letting and parting with possession), **4.8** (cleaning, maintenance and repair), **4.10** (use of the Premises), **4.13** (the Lessee's insurances) and **4.17** (indemnity) of this Lease is an essential term of this Lease.

4.2 Default

If:

- (a) any Rent or any other moneys payable under this Lease remain unpaid for fourteen (14) days after written demand has been received by the Lessee from the Lessor; or

- (b) an order is made or a resolution is effectively passed for the winding up of the Lessee (other than for the purpose of amalgamation or reconstruction) or the Lessee becomes bankrupt or if any deed of assignment or deed of arrangement is prepared by or for or presented to the Lessee for execution by it or there is appointed under any Act or instrument or by order of any Court a manager or an administrator or a trustee or a receiver or a receiver and manager or liquidator in relation to any part of the Lessee's undertakings or assets or property; or
- (c) the Lessee fails within the time specified in a notice (which time shall be not less than seven (7) days) requiring the Lessee to remedy a non-monetary breach by the Lessee of any one or more of the provisions of this Lease unless the non-performance or non-observance has been waived or excused by the Lessor in writing;
- (d) the Premises are deserted or vacated; or
- (e) the Lessee being an incorporate association:
 - (i) is wound up or resolves to be wound up voluntarily,
 - (ii) without the prior consent of the Lessor, changes its name, objects, rules or constitution,
 - (iii) is convicted of an offence under the Associations Incorporations Act 1987.

then and in each case the Lessor or any person or persons duly authorised by the Lessor at any time thereafter and without any notice or demand may re-enter into and upon the Premises and repossess the Premises and thereby the Term and the estate and interest of the Lessee in the Premises will immediately determine.

The Lessor's right of action referred to above is without prejudice to the right of action or other remedy which the Lessor has in respect of any prior breach by the Lessee of any provision of this Lease and following such forfeiture the Lessor is entitled to recover from the Lessee damages for loss of the benefits which performance of the provisions of this Lease by the Lessee would have conferred on the Lessor between the date of forfeiture and the expiry of this Lease by the effluxion of time.

6.3 Execution of Works by Lessor

If and whenever the Lessee fails within the time specified in a notice issued pursuant to **clause 6.2(c)** to remedy a breach of a provision of this Lease, the Lessor may (without prejudice to any other rights or remedies of the Lessor) enter upon the Premises, carry out or execute any repairs, requisitions, notices or works, remedy any default, pay or discharge any outgoings or other moneys or do any act, matter or thing the Lessor thinks necessary or desirable to ensure or secure compliance with the provisions of this Lease and the Lessee must repay any moneys expended by the Lessor for that purpose on demand and any moneys so expended are deemed to be rent in arrears and may be recovered by the Lessor accordingly.

4 Interest on Overdue Money

Without affecting the rights, powers and remedies of the Lessor under this Lease, the Lessee agrees to pay to the Lessor on demand interest on any money due by the Lessee to the Lessor pursuant to this Lease but unpaid for seven (7) days calculated from the due date for payment until payment in full and computed at the rate per cent per annum which is from time to time 2% above the prime rate of interest (expressed as a rate per cent per annum) charged by the Lessor's bankers on loans of less than \$100,000.00 from time to time and such interest is deemed to be rent in arrears and may be recovered by the Lessor accordingly.

5 Acceptance of Rent Not to Prejudice Lessor's Right

Demand for or acceptance of Rent or any other amounts payable by the Lessee in terms of this Lease after default by the Lessee under this Lease (other than on the grounds of non-payment of that rent or the other amounts as the case may be) will not affect the exercise by the Lessor of the rights and powers conferred upon the Lessor by this Lease and will not operate as an election by the Lessor to exercise or not to exercise any right or power.

DAMAGE OR DESTRUCTION

7.1 Damage or Destruction

- (a) Subject to the provisions of **clause 7.2** if the Premises are at any time during the Term totally or partially destroyed or damaged so as to render the Premises unfit for the occupation and use of the Lessee or inaccessible, the Rent and any other moneys payable by the Lessee under the terms of this Lease ("**Amounts Payable**") or a proportionate part of the Amounts Payable according to the nature and extent of the damage sustained shall abate and all or any remedies for recovery of the Amounts Payable falling due after the destruction or damage or a proportionate part of the Amounts Payable shall be suspended until the Premises have been rebuilt or made fit for the occupation and use of the Lessee or accessible to the Lessee as the case may be.
- (b) The abatement of the Amounts Payable referred to above shall not apply in case of destruction or damage caused by the Lessee or if any policy or policies of insurance have been vitiated or payment of the policy moneys refused because of the act, default or omission of the Lessee or of any servant, agent, invitee or licensee of the Lessee.
- (c) If there is any dispute between the parties concerning the interpretation of this **clause 7.1** that dispute must be referred to the award of a single arbitrator (who must conduct the arbitration in accordance with the provisions of the Commercial Arbitration Act 1985) to be appointed in default of agreement between the parties by the President for the time being of the Property Institute (Inc.) WA Division, at the request of either the Lessor or the Lessee, whose appointment is final and the Lessee must pay the Amounts Payable without any deduction or abatement until the date of the award of the arbitrator whereupon the Lessor must refund any of the Amounts Payable which according to the award has been overpaid. Each party is entitled to legal representation at any such arbitration.

7.2 Total Damage or Destruction

If the Premises are at any time during the Term destroyed or damaged to an extent as to be wholly unfit for occupation and use either party may by notice in writing to the other of them given within twenty eight (28) days after the event determine this Lease and thereupon this Lease is determined without prejudice however to the liability of the Lessee under this Lease up to the date of determination.

8. GST

- (a) Unless otherwise expressly stated, all Rent, prices or other sums payable or consideration to be provided under or in accordance with this document are exclusive of GST.
- (b) If GST is imposed on any supply made under or in accordance with this document, the recipient of the taxable supply must pay to the supplier an additional amount equal to the GST payable on or for the taxable supply. Payment of the additional amount will be made at the same time as payment for the taxable supply is required to be made in accordance with this document.
- (c) If this document requires a party to pay for, reimburse or contribute to any expense, loss or outgoing ("reimbursable expense") suffered or incurred by another party, the amount required to be paid, reimbursed or contributed by the first party will be the sum of:
 - (i) the amount of the reimbursable expense net of input tax credits (if any) to which the other party is entitled in respect of the reimbursable expense ("net amount"); and
 - (ii) if the other party's recovery from the first party is a taxable supply, any GST payable in respect of that supply.
- (d) If a GST inclusive price is charged, the supplier must provide the recipient of the supply a valid tax invoice at or before the time of payment.

9. LIMITATION OF LIABILITY OF LESSOR

The Lessor's obligations under this document:

- (a) bind only the person holding the reversionary estate of the Premises immediately expectant upon the expiry of the Term; and
- (b) only render the Lessor liable in damages when the act omission or default giving rise to damages occurs while the Lessor is the registered proprietor of the Premises or while the Premises are vested in the Lessor (as the case may be).

0. SPECIAL CONDITIONS

The Lessor and the Lessee agree that the special conditions (if any) set out in item 11 of the Schedule shall apply and agree with each other to observe and perform the obligations on the part of each of them set out in item 11 of the Schedule.

1. MISCELLANEOUS PROVISIONS

The Lessor and the Lessee agree that:

1.1 Notices

All notices, consents and approvals or any demand to be given or made upon the Lessee shall be made in writing and may be signed by the Lessor or its solicitors or agents and any notice to be given pursuant to this Lease is deemed to have been duly served on the party to whom it is to be given if served in the manner provided in Section 135 of the Property Law Act, 1969 and, in addition, in the case of a notice to the Lessee if left addressed to the Lessee at the Premises.

1.2 Holding Over

- (a) If the Lessee remains in possession of the Premises after the expiry of the Term with the consent of the Lessor the Lessee will be a monthly tenant of the Lessor at a monthly rent equivalent to one twelfth of the aggregate of the rent payable upon the expiry of the Term which would be payable by the Lessee if an extension of the Term had been granted at the expiry of the Term and otherwise on the same terms and conditions as this Lease (except **clause 3.2**).
- (b) The Lessor may give to the Lessee notice in writing at any time specifying a Rent being an amount greater than the Rent referred to in **clause 11.2(i)** and the Lessee shall commence paying the Rent specified in the notice at the commencement of the months following the receipt of the notice.

1.3 Waiver

No waiver by the Lessor of any breach of any provision of this Lease by the Lessee operates as a waiver of another breach of any provision of this Lease by the Lessee.

1.4 Severance

If any part of this Lease is or becomes void or unenforceable then that part is or will be severed from this Lease so that all parts not void or unenforceable remain in full force and effect and unaffected by that severance.

1.5 Statutory Powers

The powers conferred by or under any statute except to the extent inconsistent with the terms and provisions expressed in this Lease) are in augmentation of the powers conferred on the Lessor by this Lease.

1.6 Governing Law and Jurisdiction

- (a) This document is governed by and is to be construed in accordance with the laws in force in Western Australia.

- (b) Each party irrevocably and unconditionally submits to the non-exclusive jurisdiction of the courts of Western Australia and any courts which have jurisdiction to hear appeals from any of those courts and waives any right to object to any proceedings being brought in those courts.

11.7 Joint and Several Liability

An obligation of two or more persons binds them jointly and severally.

11.8 Time of the Essence

Time is of the essence in respect of the performance and observance by the Lessee of the provisions of this Lease.

SCHEDULE**1. Premises (Clauses 1.1 and 3.1)**

Portion of Reserve number 27330 (Narrogin Lot 1561) delineated and hatched as shown on the attached document.

2. Rights (Clause 3.1)

Nil.

3. Reservations (Clause 3.1)

Nil.

4. Term (Clause 3.1)

Commencement Date: 1 June 2001

Expiration Date: 31 May 2022

5. Rent (Clauses 3.1 and 4.1)

One Dollar (\$1.00) per annum.

6. Further Term (Clause 3.2)

Nil.

7. Frequency with which Premises to be Painted (Clause 4.9)

To be negotiated between Lessee and Lessor.

8. Permitted Use (Clause 4.10(b))

Corquet and Clubrooms.

9. Lessee's Additional Insurance Obligations (Clause 4.13(c))

A special risk policy in the name(s) of the Lessee to cover the contents and all plate glass installed on the Premises against loss or damage by fire, fusion, explosion, smoke, lightning, flood, storm, tempest, rain, water, water damage, leakage, earthquake, riot, civil commotion, malicious damage, impact by vehicles, aircraft and articles dropped therefrom and any other risks required by the Lessor, such cover not to be less than the full insurable value of the plate glass and contents on a replacement and/or reinstatement basis.

10. Lessor's Insurance Obligations (Clause 5.2)

A building and industrial special risk policy to cover the Premises against loss or damage by fire, fusion, explosion, smoke, lightning, flood, storm, tempest, rain, water, water damage, leakage, earthquake, riot, civil commotion, malicious damage, impact by vehicles, aircraft and articles dropped therefrom and any other risks required by the Lessor, such cover not to be less than the full insurable value of the Premises on a replacement and/or reinstatement basis.

11. Special Conditions (Clause 10)

Nil.

EXECUTED as an agreement.

THE COMMON SEAL of the TOWN)
OF NARROGIN was hereunto affixed)
by authority of a resolution of the Council)
in the presence of:)



..... *S.A. Higgins*)
Sally Anne Higgins)
Mayor)

..... *[Signature]*)
Gary Keith O'Neil)
Acting Chief Executive Officer)

THE COMMON SEAL of NARROGIN)
CROQUET CLUB INC was hereunto)
affixed by authority of a resolution of the)
Club / Committee in the presence of:)



..... *K. Bradley*)
President)

..... *KATHY BRADLEY*)
Name of President)
(print)

..... *[Signature]*)
Vice-President)

..... *John M. Knight*)
Name of Vice-President)
(print)

..... *[Signature]*)
Secretary)

..... *John M. Knight*)
Name of Secretary)
(print)

Signed for the STATE OF WESTERN AUSTRALIA for
and on behalf of the MINISTER FOR LANDS by
.....
REGIONAL MANAGER, SOUTH EAST
a DOLA officer delegated the Minister's powers under
Section 9 of the Land Administration Act 1997 in the
presence of
[Signature]
PROJECT OFFICER

4015/Croquettease

North
Scale 1 : 500

Earl Street

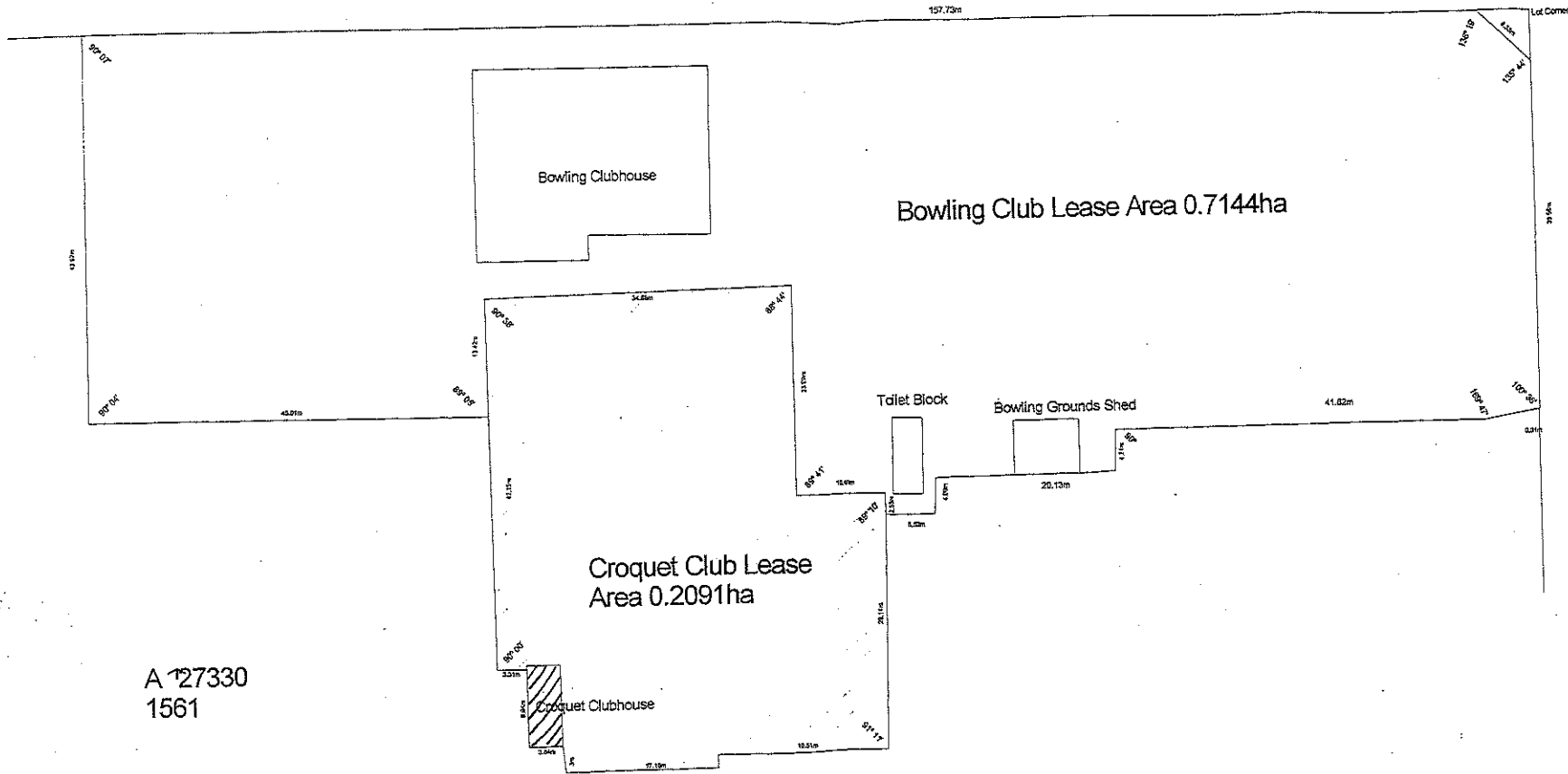

A 127330
1561

PH and KE Gow (Licensed Surveyor)
PO Box 593
Narrogin WA 6312
physical 98315140

Itemref	Quantity	Title/Name, designation, material, dimension etc			Article No./Reference	
Designed by XXX	Checked by P Gow	Approved by - date XXX - 00/00/00	Filename CROQUET.CAD	Date 14/02/01	Scale 1:500	
Town of NGN				Croquet / Bowling		
				100	Edition 1	Sheet 1/1

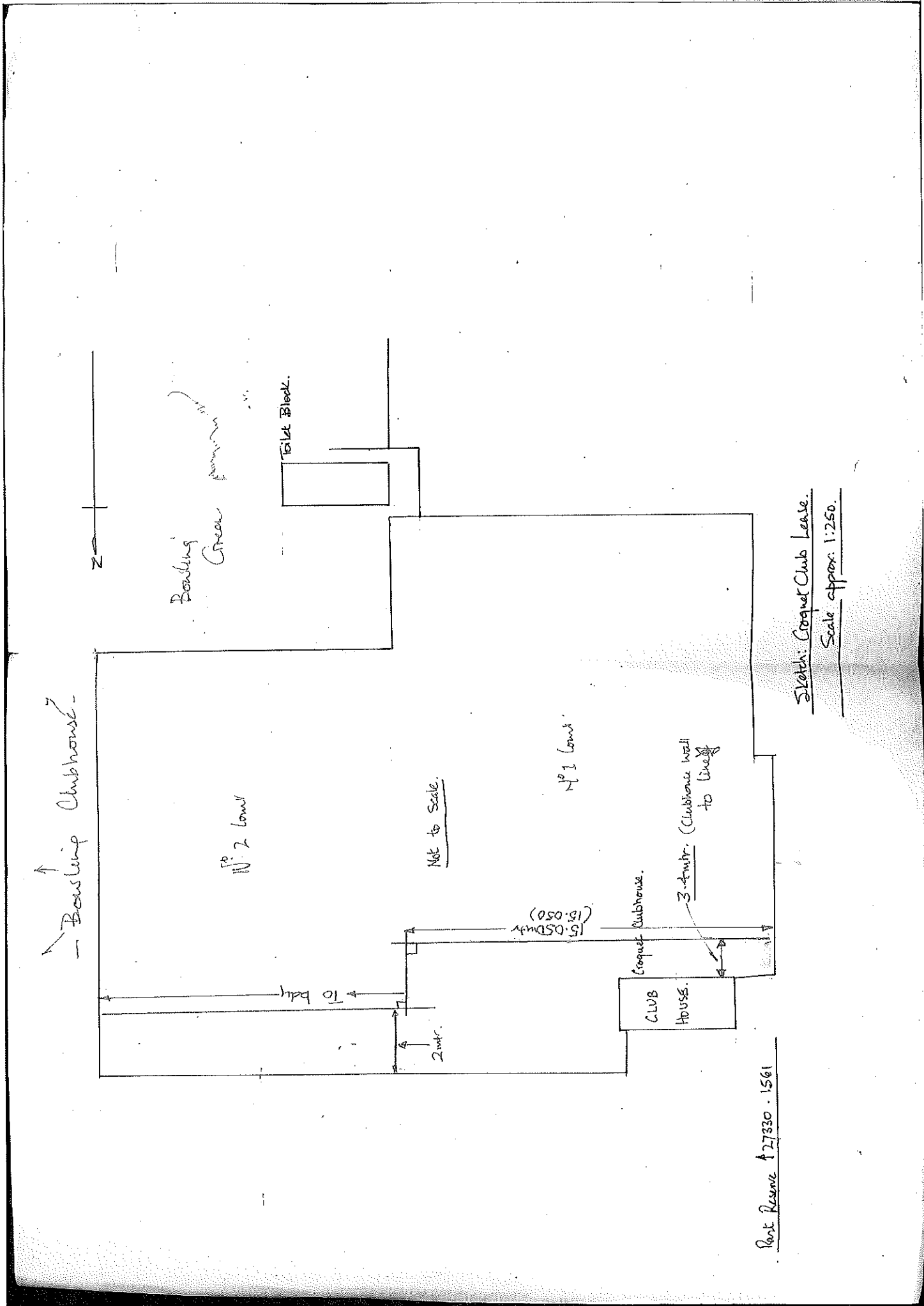

**Narrogin Bowling Club
58 Earl Street,
Narrogin WA 6312**

TO:
Narrogin Croquet Club
Earl Street,
Narrogin WA 6312

Dear Croquet Members,

At a recent Bowling Club committee meeting, the members discussed a proposal for the bowling club to take our boundary fence, between Narrogin Bowling Club's B green and Narrogin Croquet Club's lawn two, back 2.4 metres, the equivalent of one panel length, into lawn two.

This would enable the bowling club to extend the seating area of B green and allow people easy movement through this area. In exchange, Narrogin Bowling Club proposes to allow the Narrogin Croquet Club to take permanent control of C green at the rear of the bowls clubhouse.

We feel that this agreement would be of benefit to both our clubs.

If you are in agreeance with this proposal, we would like to shift the fence back as soon as possible (while current work with our B green is in progress) so ask that we have a decision to us before the end of June.

If you require further information please call me on 0427 880 976.

Kind regards



Steve Strahan
President NBC
10/05/2021 

Mr. Steve Strahan

President

Narrogin Bowling Club

13th May 2021

Dear Steve

Following receipt of your letter regarding the resumption of 2.4 meters of lawn 2 southern fence we have made further investigations to the Shire.

It occurred to us that if we agree to allow the resumption we need to move our northern fence of lawn 2 to make the green regulation size to allow for tournaments etc.

As the Shire of Narrogin is the lessor of both the Bowling Club and Croquet Club and they don't approve us moving the north fence we will not have a regulation lawn.

Malcolm Poultney (Vice Pres.) and myself had a meeting with Torre Evans this morning who said no application had been received from you regarding the resumption of 2.4 m of our common southern fenceline.

Mr Evans said you need to make application as soon as possible so some sort of dialogue can be initiated. If we are successful in negotiations it may be that the Croquet Club apply to move the North fence as far as is required to make a 4th lawn in the future.

We are having a meeting Saturday morning, 15th May to test the feelings of our Club members on these issues. As soon as we have an outcome you will be advised.

We are not trying to be difficult but it needs to be done correctly so there are no comebacks in the future or to any future committees etc.

Yours sincerely

Phil de Gruchy

Narrogin Croquet Club President

Narrogin Croquet @ outlook.com

*Phil de Gruchy
McFarlane
Clayton Rd
0408 815 363*



Narrogin Bowling Club

58 Earle Street

Narrogin WA 6312

Attention: Club President

15.05.2021

Dear Steve

At our meeting this morning the members of Narrogin Croquet Club voted unanimously, that, in principle, to support your request to resume 2.4 metres of our common fenceline of Number 2 lawn, south end.

As we have agreed to your request we now ask, as per your letter 10.5 2021, To sign Lawn 3(C green) over to the Narrogin Croquet Club without any conditions or incumberences.

The following conditions are listed before fence removal can take place:

1. That the Shire of Narrogin are in agreeance to the resumption and also agree to look at our moving the North fence of lawn 2 ,2.4 meters north and to consider that we are given more land North so that perhaps in the future to establish a 4th Lawn.

2. We need to agree who pays and how much for said removal and relocation of fence on Lawn 2 ,the cost of relocation of reticulation and any electrical wiring associated with this. We also need to agree or ascertain who will pay the cost of moving the North fence and purchase of new materials as and if required and establishment of extra lawn if required.

3. Who is going to do the work?? Most of our members are aged and are concerned of level of fitness required to undertake all of the above tasks.

We will be forwarding a copy of this letter to the Shire so there are no misunderstandings of what this is all about.

After next week you will need to confer with Malcolm Poultney VP. in my absence. His number is 0428 536 478

Yours sincerely

Phil de Gruchy President Narrogin Croquet Club

A handwritten signature in black ink, appearing to read 'Phil de Gruchy', written over a horizontal line.

A115310

ICR2123824

Shire of Narrogin
RECEIVED

17 MAY 2021

Mr.Torre Evans

Shire of Narrogin

15.05.2021

Re: Attached letters

Dear Mr.Evans

Thank you for seeing Malcolm and myself last week and now attach relevant letters to our visit.

- 1.Initial letter of enquiry from Narrogin Bowling Club
- 2.Initial response from Narrogin Croquet Club to the Bowling Club
- 3.Outcome of our meeting to Narrogin Bowling Club.

As I am away from Friday on your contact points will be :

Mr.Steve Strahan President Narrogin Bowling Club 0427 880 976

Mr.Malcolm Poultney Vice Pres.Narrogin Croquet Club 0428 536 478

We look forward to a decision to this that will be beneficial to all parties.

Thank you

Yours sincerely

Phil de Gruchy

President Narrogin Croquet Club

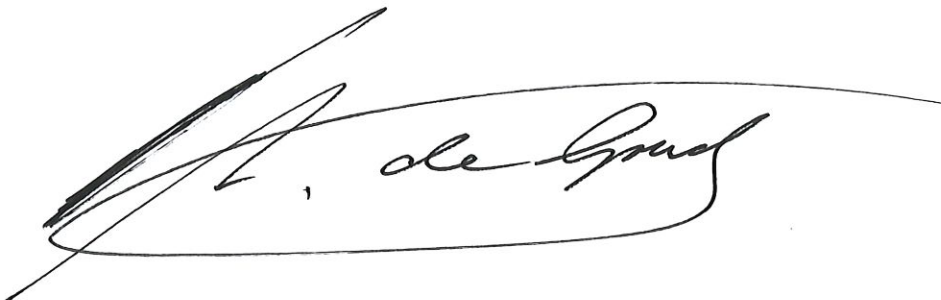
A handwritten signature in black ink, appearing to read 'Phil de Gruchy', written over a horizontal line.

20 MAY 2021



Narrogin Bowling Club
58 Earl Street
Narrogin W.A. 6312
Ph: (08) 9881 1414
Email: narroginbowlsclub@gmail.com

*what abt
Green C?
see
letter
for
NBC to
NCC*

Mr Torre Evans
Executive Manager Technical & Rural Services
Shire of Narrogin
Earl Street,
Narrogin.
WA 6312

Dear Sir,
The Narrogin Bowling Club and Narrogin Croquet Club are seeking approval in moving two fences on the Shire of Narrogin's property between the two clubs.
Both clubs agree that the whole of the south fence on Croquet lawn 2 move north 2.4mts and the north fence on Croquet lawn 2 move north 3.4mts. This will give the Bowling Club more room for players and spectators to move freely and unhindered along the edge of B green.
At the same time this gives the Croquet club a competition size lawn 2 to play on with a 1.2mt walkway alongside Bowling Club C green.
We respectfully ask that we have a response regarding this matter as soon as practical.
Please see attached photograph.

*(1) nothing new
(2) leave it*

Regards
Steve Strahan
President NBC

Regards
Phil DeGruchy
President NCC

*Cost all do NBC fences
- green to NCC*



10.4.2 POLICY MANUAL – 2021 REVIEW

File Reference	File No
Disclosure of Interest	Neither the Author nor Authorising Officer have any Impartiality, Financial or Proximity Interests that requires disclosure.
Applicant	Shire of Narrogin
Previous Item Numbers	None
Date	10 June 2021
Author	Niel Mitchell – Governance Consultant
Authorising Officer	Dale Stewart – Chief Executive Officer
Attachments	1. Policy Manual Review 2021 – incorporating draft amendments

Summary

Council is requested to consider amendments to the Policy Manual, which is to have a detailed review at least once every two years.

Background

The Policy Manual records various matters that are required by legislation, and the standing instructions of Council to staff on a range of legislative and internal processes.

The Local Government Act 1995 section 2.7 provides that it is a role of Council to set the policies for the local government.

Consultation

Consultation has been undertaken with the following officers:

- Chief Executive Officer;
- Executive Management Team; and
- other relevant staff.

Statutory Environment

Local Government Act 1995 S2.7 – Council role to determine the policies of the local government.

Policy Implications

Summary of changes recommended are:

Policy or Schedule	Clause	Explanation
3.5	5	Extension of ineligibility for rate prizes.
3.8	6(a)(ii)	Amend to specify Code of Conduct for Employees determined by the CEO.

Policy or Schedule	Clause	Explanation
3.9	16	Amend to specify Policy 1.1 separate from Code of Conduct for Employees.
3.10	6(a) 7(a) 7(b) 7(d) 10	Amend to correct position title. Amend to correct position title. Amend to require spot audits as noted by auditors. Amend to correct position title. Insert new clause relating to stocktake of portable and attractive assets as noted by auditors.
3.11	All	Replacement to avoid need to constantly update the policy throughout the year for legislative and Accounting Standards changes, or as required by auditors.
Sch.3.11	All	Delete, now to be confirmed by Council in adoption of the annual statements.
5.2	3(a),(b),(c) 7(a)	To better align this clause with the Bush Fire Brigade Local Law and delegations to CEO. Amend to include Local Law now adopted.
7.1	1 3	Amend to correct department name and Standards. Amend to correct position title.
Sch.7.1	All	Replacement in favour of current Departmental requirements.
8.20	2	Correction of name of Superannuation Guarantee Contributions (SGC) as per legislation.
8.21	2	Insertion of words previously missing.
9.3	3 – 2 nd paragraph	Amend to specify Code of Conduct for Employees determined by the CEO.
12.11	13	Insert new clause relating to stocktake of portable and attractive assets as noted by auditors.
12.13	4	Amend to correct position title.

Generally, throughout the document, changes to statutory references, corporate references, guidance notes, spelling and punctuation have been made.

Although not part of adopted policy, the preface to Part 8 Personnel has also been amended in line with recent legislative changes.

Policy may be amended at any time by Council resolution, noting that any changes may require an absolute majority decision and/or advertising of those particular policies. These requirements are advised within the Notes section of the relevant policies.

Financial Implications

There are no financial implications in the delegations emanating to the review that did not exist prior to the review.

Strategic Implications

Shire of Narrogin Strategic Community Plan 2017-2027		
Objective	4.	Civic Leadership Objective (Continually enhance the Shire's organisational capacity to service the needs of a growing community)
Outcome:	4.1	An efficient and effective organisation
Strategy:	4.1.1	Continually improve operational efficiencies and provide effective services
Strategy:	4.1.2	Continue to enhance communication and transparency
Outcome:	4.2	An employer of choice
Strategy:	4.2.1	Provide a positive, desirable workplace

Comment/Conclusion

The detailed review is attached with some changes recommended.

Any amendments to the Policy Statement that are of a substantive nature are to be resolved by Council.

Voting Requirements

Absolute majority

OFFICERS' RECOMMENDATION

That Council adopt the Policy Manual as per Attachment 1.



89 Earl Street, Narrogin
Correspondence to:
PO Box 1145, Narrogin WA 6312
T (08) 9890 0900
E enquiries@narrogin.wa.gov.au
W www.narrogin.wa.gov.au

COUNCIL POLICY MANUAL

(NOTE: Including Standards adopted under the Local Government Act 1995, but excluding policies adopted by the Council pursuant to the Planning and Development Act 2005 and former Shire of Narrogin Town Planning Scheme No. 2 and former Town of Narrogin Town Planning Scheme No. 2)

CURRENT AS AT 29 APRIL 2021

[REVIEW JUNE 2021 – TRACKED ALL CHANGES](#)



History Summary

Item	Date	Action	Description
1	26 April 2017	Revocation	Resolution of Council 0417.048 All previous policies, except – 1.3 - Elected Members – Recognition of Service
2	26 April 2017	Adoption	Resolution of Council 0417.048 All policies adopted
3	28 June 2017	Adoption	Resolution of Council 0617.081 1.10 - Related Parties Policy
4	27 September 2017	Amendment	Resolution of Council 0917.115 14.2 - Plant Equipment and Vehicle Replacement (now 12.10)
5	22 August 2018	New Policy	Resolution of Council 0818.080 14.3 - Asset Management Policy (now 12.11)
6	26 September 2018	New Policy	Resolution of Council 0918.095 3.7 - Investments and 3.8 - Transaction Cards policies
8	24 October 2018	New Policy	Resolution of Council 1018.101 15.3 – Street Trees (now 13.3)
9	26 November 2018	Edit	28/11/2018 – Editing to insert preface into front of Manual and note on front cover relating to TPS policies.
10	20 December 2018	New Policy	Resolution of Council 1218.133 3.9 – Complaints Management
11	24 July 2019	Major Biennial Review	Resolution of Council 0719.12
12	16 August 2019	Amendment	As per resolution 0719.012, the word "Trust" changed to 'Municipal' in Policy 10.1, paragraph 3.
13.	24 September 2019	Edit	Referencing form to be used in policy 1.10
14.	8 October 2019	Amendment	Addition to Notes section with Form FCEO041 to Policy 1.1
15.	8 October 2019	New Policy	Resolution of Council 0919.004 1.14 - Community Engagement Policy
16.	27 November 2019	New Policy	Resolution of Council 1119.016 2.9 - Annual Closure During Christmas Period
17.	25 February 2020	New Policy	Resolution of Council 0220.023 1.15 - Elected Member, Chief Executive Officer and Employee Attendance at Events Policy
18.	16 March 2020	Amendment	Administrative – Linked Customer Service Charter under heading of Forms and Templates into policy 3.9.
19.	23 June 2020	New Policy	Resolution of Council 0320.014 1.16 - Fraud and Corruption Prevention Policy
20.	23 June 2020	New Policy	Resolution of Council 0320.017 1.17 - Continuing Professional Development
21.	23 June 2020	New Policy	Resolution of Council 0420.005 6.1 - Itinerant Vendor Policy
22.	25 June 2020	Amendment	Resolution of Council 0520.017 Policy 3.1. - Purchasing

Item	Date	Action	Description
23.	29 July 2020	New Policy	Resolution of Council 0720.003 Policy 10.3 - Colour Palette and Sign Guide (Central Business Precinct).
24.	29 July 2020	New Policy	Resolution of Council 0720.012 Policy 3.12 - COVID 19 Financial Hardship
25.	24 September 2020	New Policy	Resolution of Council 0720.015 Policy 3.13 - Rating – Change in Predominant Use of Rural Land
26.	24 September 2020	New Policy	Resolution of Council 0820.003 Policy 11.4 - Public Art Contribution Policy
27.	24 September 2020	New Policy	Resolution of Council 0920.008 Policy 3.14 - Rating – Contiguous Land Use
28.	24 September 2020	Amendment	Resolution of Council 0419.002 Policy 5.2 - Bush Fire Brigades Management
29.	25 November 2020	Amendment	Resolution of Council – 1120.004 Policy 9.1 Occupational Safety & Health Policy
30.	5 February 2021	Amendment	Administrative edit to preface for purposes of recording policies requiring adoption, eg insertion of red text to alert author.
31.	25 February 2021	Amendment	Preface updated as a result of new Policies adopted at Council Meeting of 24/2/21.
32.	25 February 2021	New Policy	Resolution of Council 0221.016 Replacement of Policy 1.1 with new Code of Conduct for Council Members, Committee Members and Candidates for Local Government Elections.
33.	25 February 2021	New Policy (Standard)	Resolution of Council 0221.017 Inclusion of new mandatory minimum standards that cover the recruitment, selection, performance review and early termination of LG CEO – Policy 1.18.
34.	25 February 2021	Amendment	Resolution of Council 0221.018 Amended Policy 2.1 - Senior Employees and Acting Chief Executive Officer appointments.
35.	29 April 2021	Amendment	CEO Requested that notes be added to 3.10 Portable and Attractive Assets – link to SoN Artwork Collection in Smartsheet.
36.	29 April 2021	New Policy	Resolution of Council 0421.009 11.5 Advertising/Sponsorship signs – in Shire buildings and facilities.
37.	26 May 2021	Amended policy	Resolution _____ 3.14 Rating – Contiguous Land Use

Preface

The Policy Manual is the compiled decisions of Council to the Chief Executive Officer (CEO), employees and other officers, detailing how specific matters are to be administered, the standards to apply etc.

Council Policy is over-riden by –

- Commonwealth and State legislation and regulations,
- the Local Planning Schemes
- Local Laws
- Council resolutions
- Delegations

Council Policy overrides –

- Executive Instructions
- Local Government Guidelines –
 - o although are not decisions of Council, close observance is strongly recommended
- administrative directions/instructions

The decisions can be made at any time, and may be varied at Council's discretion. Council Policy is not binding on the Council, but is binding on employees and officers, unless discretion is stated. Council Policy is to be considered as Council's standing or permanent instructions.

The Local Government Act requires the development of only a few policies, otherwise all policies are at Council's sole discretion.

Policies, Codes or Standards of a local government required by the Local Government Act 1995 include:

- Adoption of an Attendance at Events Policy (S5.90A)
- Adoption of a Council Members [committee members and candidates](#) Code of Conduct (S5.104)
- Adoption of an Employees Code of Conduct (S5.51A) [to be made by the CEO](#)
- Adoption of Continuing Professional Development Policy for Elected Members (S5.128)
- Adoption of a Policy relating to employing a CEO or Acting CEO (S5.39A and B and C)
- Adoption of Regional Price Preference Policy (R24C Local Government (Functions and General) Regulations 1996)
- Adoption of a Policy that pays employees more than required by their contract or award (recognition of service / gratuity) (S5.50); and
- Adoption of a Standard for CEO recruitment, performance and termination (based on model) (S5.39B).

Other than the above, Policies are generally not required to be based on or in legislation, but can be a stand-alone instruction of Council. However, it cannot be inconsistent with legislation.

Within the Policy Manual is a detailed outline of –

- how actions and administrative decisions are to be made,
- when they are to be implemented or made,
- limitations and restrictions etc.

The Policy Statement is resolved by Council. All procedural or reference information, formatting and spelling errors may be amended or updated by the CEO.

Contents

INTRODUCTION	8
Section 1 - COUNCIL / GOVERNANCE	11
1.1 Code of Conduct	11
Policy Schedule 1.1 – Code of Conduct	12
1.2 Acknowledgement of Noongar People	19
1.3 Elected Members – Recognition of Service	20
1.4 Public Question Time – Management	22
Policy Schedule 1.4 – Public Question Time	23
1.5 Elected Members – Briefing Sessions	24
1.6 Recording of Council Meetings	26
1.7 Legal Representation for Elected Members and Employees	27
Policy Schedule 1.7 – Legal Costs Indemnification	28
1.8 Elected Members – Conference, Training, Travel and out of pocket Expenses	29
1.9 Elected Member Records – Capture and Management	31
1.10 Related Party Disclosures (AASB 124)	33
Policy Schedule 1.10 – Related Party Disclosures – Definitions	37
1.11 Common Seal	38
1.12 Internal Control	39
1.13 Legislative compliance	41
1.14 Community Engagement Policy	44
1.15 Elected Member and Chief Executive Officer Attendance at Events Policy	50
1.16 Fraud and Corruption Prevention	54
1.17 Continuing Professional Development	55
1.18 Standards for CEO Recruitment, Performance and Termination	57
Policy Schedule 1.18 Standards for CEO Recruitment, Performance and Termination	58
Section 2 - ADMINISTRATION / ORGANISATION	62
2.1 Senior Employees – Designation & Appointing Acting CEO	62
2.2 Acting / Relieving Staff Authority	63
2.3 Display of National and Other Flags	64
2.4 Amendments to Council Policy	65
2.5 Information & Communications Technology Usage	66
2.6 Social Media	67
2.7 Shire Logo	68
2.8 Enterprise Risk Management	69
Policy Schedule 2.8 – Risk Appetite	71
2.9 Annual Closure During Christmas Period	73
Section 3 - FINANCIAL MANAGEMENT	74
3.1 Purchasing	74
Policy Schedule 3.1(a) – Purchasing Principles	76
Policy Schedule 3.1(b) – Purchasing Thresholds and Requirements	77
Policy Schedule 3.1(c) – Regulatory Compliance	80
3.2 Purchasing – Regional Price Preference	82
Policy Schedule 3.2 – Regional Price Preference	83
3.3 Self-Supporting Loans	85
3.4 Ex-Gratia Payments	86

3.5	Rates – Prize Eligibility	87
3.6	Rating – Merger Parity Transition	88
3.7	Investments.....	90
3.8	Transaction Cards.....	93
3.9	Complaints Management	97
3.10	Portable and Attractive Assets.....	101
3.11	Significant Accounting Policies	104
3.12	COVID 19 Financial Hardship.....	105
3.13	Rating – Change in Predominant Use of Rural Land	108
3.14	Rating – Contiguous Land Use	109
Section 4 - ORDER / PUBLIC SAFETY		111
Section 5 - FIRE CONTROL		112
5.1	Bush Fire Brigades – Establishment.....	112
	Policy Schedule 5.1 – Bush Fire Brigade areas	113
5.2	Bush Fire Brigades – Management	114
5.3	Firebreaks and Fuel Hazard Reduction – Inspection & Prosecution	116
5.4	Harvest & Movement of Vehicles Bans	117
5.5	FCO Duties	118
5.6	Fire Fighting – Emergency plant hire	119
Section 6 - ENVIRONMENTAL HEALTH / FOOD		120
6.1	Itinerant Vendor Policy	120
Section 7 - COMMUNITY SERVICES.....		125
7.1	Narrogin Regional Homecare – Management	125
	Policy Schedule 7.1 – Narrogin Regional Homecare Procedures Manual	126
Section 8 - PERSONNEL		127
8.1	Disciplinary Action.....	129
8.2	Discrimination, Harassment and Bullying	130
8.3	Employee Performance and Development	131
8.4	Grievance.....	132
8.5	Higher Duties	133
8.6	Leave – Award Entitlements	134
8.7	Leave – Community Service	135
8.8	Leave – Long Service	137
8.9	Probationary Periods of Employment	138
8.10	Recruitment and Selection.....	139
8.11	Rostered Days Off	140
8.12	Secondary Employment.....	141
8.13	Training, Study and Education	142
8.14	Uniforms, PPE and Personal Presentation.....	144
8.15	Use of Fleet Vehicles – Work and Private Usage.....	145
8.16	Use of Private Vehicles – Work Purposes	146
8.17	Workplace Surveillance	147
8.18	Salary Sacrifice	148
8.19	Employees – Recognition of Service (Gratuity)	149
8.20	Employee Superannuation.....	151
8.21	Equal Employment Opportunity	152
Section 9 - OCCUPATIONAL SAFETY & HEALTH		154

9.1	Occupational Safety & Health Policy – Employees, Volunteers, Contractors, Visitors	154
9.2	Occupational Safety & Health – Executive Instructions	156
9.3	Drugs and Alcohol	157
9.4	Health and Wellbeing	161
9.5	Workplace Visitors – Management	164
9.6	Risk Management - Deleted	165
Section 10 - BUILDING / DEVELOPMENT		166
10.1	Kerb / Footpath Deposit – Adjoining Works	166
10.2	Shade Cloth Structures	167
10.3	Colour Palette and Sign Guide (Central Business Precinct)	168
Section 11 - PUBLIC FACILITIES		173
11.1	RW (Bob) Farr Memorial Library – User Rules – Deleted	173
11.2	Hire of Venues – General	174
	Policy Schedule 11.2(a) – Hire of Venues – Requirements to Hire	175
	Policy Schedule 11.2(b) – Hire of Venues etc – Conditions of Hire	177
11.3	Hire of Venues – Annual or Seasonal Use	179
11.4	Public Art Contribution Policy	180
11.5	Advertising / Sponsorship signs – in Shire buildings and facilities	183
Former Section 12 – Tourism replaced		189
Section 12 - TRANSPORT (renamed)		189
12.1	Standard Crossovers	189
12.2	Roads – Developer Subdivisions	191
12.3	Roads – Access to Lots / Locations without Road Frontage	193
12.4	Road Reserves – Stormwater Discharge	194
12.5	Road Reserves – Closure	196
12.6	Private Works	197
12.7	Road Making Materials – Non-Shire Controlled Land	198
12.8	Directional Street Signs – Non-commercial	199
12.9	After Hours Use of Depot, Plant, Vehicles, Equipment and Tools	200
12.10	Plant, Equipment and Vehicle Replacement	201
12.11	Asset Management	203
12.12	Restricted Access Vehicles on Shire Roads	207
	Policy Schedule 12.12(a) – Information for Application to Use Shire Roads	209
	Policy Schedule 12.12(b) – CA07 Conditions that may be applied	210
	Policy Schedule 12.12(c) – Components for Agreement to Use Shire Roads	211
	Policy Schedule 12.12(d) – Calculation of User Contributions	213
12.13	Number Plates – Local Authority Fundraiser Series	214
Section 13 - NATURAL RESOURCE MANAGEMENT		215
13.1	Road Reserves – Clearing	215
13.2	Road Reserves – Cutting Firewood	217
13.3	Street Trees	218
Former Section 14 – Plant / Equipment transferred to Section 12		221
Former Section 15 – Natural Resources renumbered as Section 13		221
Former Section 16 – Unclassified transferred to Section 12		221

INTRODUCTION

Statutory and Corporate context

The Council is responsible for functions and activities under numerous Acts and other legislation, many of which permit Council to delegate responsibilities and authority to various employees and officers, and to stipulate conditions, standards or methods of control and management.

This Council Policy Manual has been prepared to complement a range of obligations imposed by legislation including local laws, and various documents adopted by Council.

The order of priority for compliance is –

1. Federal and State legislation and regulations,
2. the Local Planning Scheme,
3. a specific resolution of Council,
4. Delegations Register – being specific authorisations resolved by Council, and having a statutory context under the Local Government Act,
5. Local Planning Policy – as it is made under the authority of the Local Planning Scheme, by resolution of Council,
6. Council Policy – being instructions resolved by Council on how particular matters are to be dealt with,
7. Executive Instruction – standing instructions or procedures issued by the CEO,
8. Administrative directions or instructions.

Although not decisions of Council, and therefore not a requirement of staff, consideration should be given to the following as being best practice –

- DLGRD Guidelines
- WALGA Councillors Manual, Practice Notes etc.

Unless specifically resolved that the instruction is to be included in the Policy Manual, it is considered that it is for a specific matter, and is not a general or on-going instruction.

There are some policies that have specific legislative provision, and these are noted in the individual policy.

IMPORTANT – Consequences of Breaching Council Policy

Where there is a breach of Council Policy –

- a) it may result in disciplinary action up to and including termination of employment,
- b) the Shire may also be obligated to refer a breach to an external agency where an employee may be held personally liable for their actions;
- c) the employee in breach may also be personally liable for their actions, such costs charged to the Shire or to repair as a result of the private/personal or unauthorised use.

Application – is to staff, not to community

Policy [generally](#) cannot be used to control or manage the general community – it is essentially an instruction to staff that in particular circumstances, a specific action or process is to be followed, for instance –

- Hire of facilities – if there is damage, then staff are to invoice the hirer or cancel their booking etc
- Caravan Park Rules – if a patron does not comply with these, staff are to take action
- HR / Personnel policies – outlines the circumstances in which actions are to be taken
- Crossovers – staff may approve if an application complies with requirements, or take action if a crossover does not comply.

A Policy generally cannot be applied directly to the community as they may not be aware of its adoption. The community has to have had the opportunity to be aware of the requirements imposed on them. [If a policy is to be applied to the community or to a specific applicant, there are legislative requirements that must be observed.](#)

However, policy may require staff to apply specific conditions to a licence, permit etc, and to provide a written copy of the conditions being applied. These conditions applied are then enforceable.

Advertising of a local law constitutes community wide notification, whether the person is aware of it or not. Accordingly, many policies expand on how a Local Law is to be interpreted or acted upon by staff.

Definitions

The LG Act has not defined the term "delegation" or "delegated power". However:

- s.5.16 refers to "... the exercise of any of its powers and duties ..."
- s.5.42 refers to "... the exercise of any of its powers or the discharge of any of its duties ..."

The term "policy" is not defined anywhere in the LG Act, however, Departmental guidelines refer to Council "acting through" the administration to fulfil requirements and obligations.

The following terms used in this document apply insofar as they are consistent with enabling legislation –

authority means the permission or requirement for Council, a Committee or a person to act in accordance with –

- the Local Government Act, Regulation or other legislation,
- a delegation made by Council,
- a Council Policy,
- a specific decision of Council, or
- an Executive Instruction.

delegation means the authority for a Committee, the CEO or other person to exercise a power, or discharge a duty, as conferred by absolute majority decision of Council under the provisions of the relevant legislation.

employee means a person employed by the Shire and is on the payroll, and does not include contractors or consultants

Council Policy is a standing instruction resolved by Council as to how a particular matter is to be implemented:

Executive Instruction is a standing instruction issued by the CEO as to how a particular matter is to be implemented.

instruction means the requirement for a staff member to act in accordance with a direction given by the Council, the CEO, senior employee or supervisor.

officer generally only to be used in the context of a formal authorisation, and may include an authorised employee

Guidelines No.17 – Delegations (Department of Local Government)

The Department of Local Government and Communities has published Guidelines for the formation of Delegations.

The Guidelines outline the concept of "delegation" and "acting through" in parts 3 and 4, particularly in paragraph 13 where it is stated –

... the key difference between a delegation and "acting through" is that a delegate exercises the delegated decision making function in his or her own right. The principal issue is that where a person has no discretion in carrying out a function, then that function may be undertaken through the "acting through" concept. Alternatively, where the decision allows for discretion on the part of the decision maker, then that function needs to be delegated for another person to have that authority.

In effect, "acting through" is an action that could reasonably be expected to be carried out as the result of a decision by Council (e.g. advertising of a tender), or as a function reasonably expected of the position that a person holds.

Not all matters which will be recorded in Policy are "acting through" matters. Similarly, not all "acting through" matters will be listed. Council Policy supported by Executive Instructions describe how that action or some other action is to be carried out.

Making, amending and revoking Council Policy

Administrative Policy [generally](#) requires approval by a simple majority of Council, and may be made, amended or revoked at any time by Council.

[A number of policies are required by legislation to be adopted or amended by absolute majority, and these are referenced in the Notes section of the relevant policy.](#)

Council may impose limitations on Policy or the functions delegated as they see fit.

Review of Council Policy

There is no required timetable for the review of policy, however, it is suggested that it should be done regularly to ensure that policies are relevant, current and understood.

To maintain the Policy Manual up to date, an administrative review should be reviewed at least once a year, and a report made to Council on matters needing amendment or inclusion.

It is suggested that detailed consideration of all policies be undertaken by Council at least once every two years.

Section 1 - COUNCIL / GOVERNANCE

1.1 Code of Conduct

Statutory context Sections of the Acts, Regulations and/or Local Laws that apply to this item include:
Local Government Act 1995
Local Government (Model Code of Conduct) Regulations 2021.

Corporate context

History Adopted 24 February 2021
Last reviewed [7 June 2021](#)

Policy Statement

1. The following Council Policy Schedule is adopted, and forms part of this Statement –
1.1– Code of Conduct for Council Members, Committee Members and Candidates
2. The Code of Conduct applies to Council Members, Committee Members and Candidates of Local Government Elections.

– End of Policy

Notes

Statutory requirement –

[The Local Government Act requires that the code may only be adopted or amended by absolute majority.](#)

Procedures

All Council Members, Committee Members and Candidates of LG Elections are provided with the Code of Conduct upon their appointment and /or induction.

Pursuant to Council resolution 0221.016, and the Local Government (Model Code of Conduct) Regulations 2021;

Clause 11 (3), Council has authorised the following persons to receive Division 3 complaints and withdrawals of same, relating to Council Members, Committee Members and Candidates (that become Council Members):

- i) The Shire President with respect to complaints made by anyone, excluding the Shire President;
- ii) The Deputy Shire President with respect to complaints made by the Shire President, excluding those made of the Deputy Shire President;
- iii) The Deputy Shire President with respect to complaints about the Shire President; and
- iv) A committee comprising all of the Council Members, excluding the Shire President and Deputy Shire President, with respect to complaints about the Deputy Shire President made by the Shire President.

Forms and Templates

A person making a complaint, alleging a breach against the Code is to submit the complaint on the form approved by the local government below.

[FCEO049 – Complaint about alleged Breach](#)

-- See over for Code of Conduct Policy Schedule --

Code of Conduct for Council Members, Committee Members and Candidates



Division 1 — Preliminary provisions

1. Citation

This is the *Shire of Narrogin* Code of Conduct for Council Members, Committee Members and Candidates.

2. Terms used

(1) In this code —

Act means the *Local Government Act 1995*;

candidate means a candidate for election as a council member;

complaint means a complaint made under clause 11(1);

publish includes to publish on a social media platform.

(2) Other terms used in this code that are also used in the Act have the same meaning as they have in the Act, unless the contrary intention appears.

Division 2 — General principles

3. Overview of Division

This Division sets out general principles to guide the behaviour of council members, committee members and candidates.

4. Personal integrity

(1) A council member, committee member or candidate should —

- (a) act with reasonable care and diligence; and
- (b) act with honesty and integrity; and
- (c) act lawfully; and
- (d) identify and appropriately manage any conflict of interest; and
- (e) avoid damage to the reputation of the local government.

(2) A council member or committee member should —

- (a) act in accordance with the trust placed in council members and committee members; and
- (b) participate in decision-making in an honest, fair, impartial and timely manner; and
- (c) actively seek out and engage in training and development opportunities to improve the performance of their role; and
- (d) attend and participate in briefings, workshops and training sessions provided or arranged by the local government in relation to the performance of their role.

5. Relationship with others

- (1) A council member, committee member or candidate should —
 - (a) treat others with respect, courtesy and fairness; and
 - (b) respect and value diversity in the community.
- (2) A council member or committee member should maintain and contribute to a harmonious, safe and productive working environment.

6. Accountability

- A council member or committee member should —
- (a) base decisions on relevant and factually correct information; and
 - (b) make decisions on merit, in the public interest and in accordance with statutory obligations and principles of good governance and procedural fairness; and
 - (c) read all agenda papers given to them in relation to council or committee meetings; and
 - (d) be open and accountable to, and represent, the community in the district.

Division 3 — Behaviour

7. Overview of Division

This Division sets out —

- (a) requirements relating to the behaviour of council members, committee members and candidates; and
- (b) the mechanism for dealing with alleged breaches of those requirements.

8. Personal integrity

- (1) A council member, committee member or candidate —
 - (a) must ensure that their use of social media and other forms of communication complies with this code; and
 - (b) must only publish material that is factually correct.
- (2) A council member or committee member —
 - (a) must not be impaired by alcohol or drugs in the performance of their official duties; and
 - (b) must comply with all policies, procedures and resolutions of the local government.

9. Relationship with others

- A council member, committee member or candidate —
- (a) must not bully or harass another person in any way; and
 - (b) must deal with the media in a positive and appropriate manner and in accordance with any relevant policy of the local government; and
 - (c) must not use offensive or derogatory language when referring to another person; and
 - (d) must not disparage the character of another council member, committee member or candidate or a local government employee in connection with the performance of their official duties; and
 - (e) must not impute dishonest or unethical motives to another council member, committee member or candidate or a local government employee in connection with the performance of their official duties.

10. Council or committee meetings

When attending a council or committee meeting, a council member, committee member or candidate —

- (a) must not act in an abusive or threatening manner towards another person; and
- (b) must not make a statement that the member or candidate knows, or could reasonably be expected to know, is false or misleading; and
- (c) must not repeatedly disrupt the meeting; and
- (d) must comply with any requirements of a local law of the local government relating to the procedures and conduct of council or committee meetings; and
- (e) must comply with any direction given by the person presiding at the meeting; and
- (f) must immediately cease to engage in any conduct that has been ruled out of order by the person presiding at the meeting.

11. Complaint about alleged breach

- (1) A person may make a complaint, in accordance with subclause (2), alleging a breach of a requirement set out in this Division.
- (2) A complaint must be made —
 - (a) in writing in [the form approved by the local government](#); and
 - (b) to a person authorised under subclause (3); and
 - (c) within 1 month after the occurrence of the alleged breach.
- (3) The local government must, in writing, authorise 1 or more persons to receive complaints and withdrawals of complaints.

12. Dealing with complaint

- (1) After considering a complaint, the local government must, unless it dismisses the complaint under clause 13 or the complaint is withdrawn under clause 14(1), make a finding as to whether the alleged breach the subject of the complaint has occurred.
- (2) Before making a finding in relation to the complaint, the local government must give the person to whom the complaint relates a reasonable opportunity to be heard.
- (3) A finding that the alleged breach has occurred must be based on evidence from which it may be concluded that it is more likely that the breach occurred than that it did not occur.
- (4) If the local government makes a finding that the alleged breach has occurred, the local government may —
 - (a) take no further action; or
 - (b) prepare and implement a plan to address the behaviour of the person to whom the complaint relates.
- (5) When preparing a plan under subclause (4)(b), the local government must consult with the person to whom the complaint relates.
- (6) A plan under subclause (4)(b) may include a requirement for the person to whom the complaint relates to do 1 or more of the following —
 - (a) engage in mediation;
 - (b) undertake counselling;
 - (c) undertake training;
 - (d) take other action the local government considers appropriate.

- (7) If the local government makes a finding in relation to the complaint, the local government must give the complainant, and the person to whom the complaint relates, written notice of —
- (a) its finding and the reasons for its finding; and
 - (b) if its finding is that the alleged breach has occurred — its decision under subclause (4).

13. Dismissal of complaint

- (1) The local government must dismiss a complaint if it is satisfied that —
- (a) the behaviour to which the complaint relates occurred at a council or committee meeting; and
 - (b) either —
 - (i) the behaviour was dealt with by the person presiding at the meeting; or
 - (ii) the person responsible for the behaviour has taken remedial action in accordance with a local law of the local government that deals with meeting procedures.
- (2) If the local government dismisses a complaint, the local government must give the complainant, and the person to whom the complaint relates, written notice of its decision and the reasons for its decision.

14. Withdrawal of complaint

- (1) A complainant may withdraw their complaint at any time before the local government makes a finding in relation to the complaint.
- (2) The withdrawal of a complaint must be —
- (a) in writing; and
 - (b) given to a person authorised under clause 11(3).

15. Other provisions about complaints

- (1) A complaint about an alleged breach by a candidate cannot be dealt with by the local government unless the candidate has been elected as a council member.
- (2) The procedure for dealing with complaints may be determined by the local government to the extent that it is not provided for in this Division.

Division 4 — Rules of conduct

Notes for this Division:

1. Under section 5.105(1) of the Act a council member commits a minor breach if the council member contravenes a rule of conduct. This extends to the contravention of a rule of conduct that occurred when the council member was a candidate.
2. A minor breach is dealt with by a standards panel under section 5.110 of the Act.

16. Overview of Division

- (1) This Division sets out rules of conduct for council members and candidates.
- (2) A reference in this Division to a council member includes a council member when acting as a committee member.

17. Misuse of local government resources

- (1) In this clause —

electoral purpose means the purpose of persuading electors to vote in a particular way at an election, referendum or other poll held under the Act, the *Electoral Act 1907* or the *Commonwealth Electoral Act 1918*;

resources of a local government includes —

- (a) local government property; and
 - (b) services provided, or paid for, by a local government.
- (2) A council member must not, directly or indirectly, use the resources of a local government for an electoral purpose or other purpose unless authorised under the Act, or by the local government or the CEO, to use the resources for that purpose.

18. Securing personal advantage or disadvantaging others

- (1) A council member must not make improper use of their office —
- (a) to gain, directly or indirectly, an advantage for the council member or any other person; or
 - (b) to cause detriment to the local government or any other person.
- (2) Subclause (1) does not apply to conduct that contravenes section 5.93 of the Act or *The Criminal Code* section 83.

19. Prohibition against involvement in administration

- (1) A council member must not undertake a task that contributes to the administration of the local government unless authorised by the local government or the CEO to undertake that task.
- (2) Subclause (1) does not apply to anything that a council member does as part of the deliberations at a council or committee meeting.

20. Relationship with local government employees

- (1) In this clause —
- local government employee** means a person —
- (a) employed by a local government under section 5.36(1) of the Act; or
 - (b) engaged by a local government under a contract for services.
- (2) A council member or candidate must not —
- (a) direct or attempt to direct a local government employee to do or not to do anything in their capacity as a local government employee; or
 - (b) attempt to influence, by means of a threat or the promise of a reward, the conduct of a local government employee in their capacity as a local government employee; or
 - (c) act in an abusive or threatening manner towards a local government employee.
- (3) Subclause (2)(a) does not apply to anything that a council member does as part of the deliberations at a council or committee meeting.
- (4) If a council member or candidate, in their capacity as a council member or candidate, is attending a council or committee meeting or other organised event (for example, a briefing or workshop), the council member or candidate must not orally, in writing or by any other means —
- (a) make a statement that a local government employee is incompetent or dishonest; or
 - (b) use an offensive or objectionable expression when referring to a local government employee.
- (5) Subclause (4)(a) does not apply to conduct that is unlawful under *The Criminal Code* Chapter XXXV.

21. Disclosure of information

- (1) In this clause —
- closed meeting* means a council or committee meeting, or a part of a council or committee meeting, that is closed to members of the public under section 5.23(2) of the Act;
- confidential document* means a document marked by the CEO, or by a person authorised by the CEO, to clearly show that the information in the document is not to be disclosed;
- document* includes a part of a document;
- non-confidential document* means a document that is not a confidential document.
- (2) A council member must not disclose information that the council member —
- derived from a confidential document; or
 - acquired at a closed meeting other than information derived from a non-confidential document.
- (3) Subclause (2) does not prevent a council member from disclosing information —
- at a closed meeting; or
 - to the extent specified by the council and subject to such other conditions as the council determines; or
 - that is already in the public domain; or
 - to an officer of the Department; or
 - to the Minister; or
 - to a legal practitioner for the purpose of obtaining legal advice; or
 - if the disclosure is required or permitted by law.

22. Disclosure of interests

- (1) In this clause —
- interest* —
- means an interest that could, or could reasonably be perceived to, adversely affect the impartiality of the person having the interest; and
 - includes an interest arising from kinship, friendship or membership of an association.
- (2) A council member who has an interest in any matter to be discussed at a council or committee meeting attended by the council member must disclose the nature of the interest —
- in a written notice given to the CEO before the meeting; or
 - at the meeting immediately before the matter is discussed.
- (3) Subclause (2) does not apply to an interest referred to in section 5.60 of the Act.
- (4) Subclause (2) does not apply if a council member fails to disclose an interest because the council member did not know —
- that they had an interest in the matter; or
 - that the matter in which they had an interest would be discussed at the meeting and the council member disclosed the interest as soon as possible after the discussion began.
- (5) If, under subclause (2)(a), a council member discloses an interest in a written notice given to the CEO before a meeting, then —
- before the meeting the CEO must cause the notice to be given to the person who is to preside at the meeting; and

- (b) at the meeting the person presiding must bring the notice and its contents to the attention of the persons present immediately before any matter to which the disclosure relates is discussed.
 - (6) Subclause (7) applies in relation to an interest if —
 - (a) under subclause (2)(b) or (4)(b) the interest is disclosed at a meeting; or
 - (b) under subclause (5)(b) notice of the interest is brought to the attention of the persons present at a meeting.
 - (7) The nature of the interest must be recorded in the minutes of the meeting.
- 23. Compliance with plan requirement**
- If a plan under clause 12(4)(b) in relation to a council member includes a requirement referred to in clause 12(6), the council member must comply with the requirement.
-

1.2 Acknowledgement of Noongar People

Statutory context None

Corporate context None

History Adopted 26 April 2017
Last reviewed 24 July 2019
[Last reviewed 7 June 2021](#)

Policy Statement

1. A Welcome to Country is to be arranged with a local Noongar Elder to recognise the traditional custodians of the area, for official major Shire of Narrogin events, including but not limited to –
 - a) events celebrating Aboriginal and Torres Strait Islander people and culture such as the official opening of NAIDOC Week,
 - b) Australia Day Citizenship Ceremonies.
2. An Acknowledgement of the Noongar People is to be read aloud at these events by the official representative of the Shire, and at other events where considered appropriate.
3. An Acknowledgment of the Noongar People is to be placed by the Shire of Narrogin in appropriate written forms, including but not limited to –
 - a) Strategic Community Plan,
 - b) Corporate Business Plan,
 - c) Shire of Narrogin website.
4. The following statement is the official Acknowledgement of Noongar people by the Shire of Narrogin –

The Shire of Narrogin acknowledges the Noongar people as traditional custodians of this land and their continuing connection to land and community. We pay our respect to them, to their culture and to their Elders past and present.

– End of Policy

Notes

1.3 Elected Members – Recognition of Service

Statutory context	Local Government Act 1995 – <ul style="list-style-type: none">- s.5.60 – when a person has an interest- s.5.60A – financial interest- s.5.69 – Minister may allow members disclosing interests to participate etc. in meetings- s.5.100A – gifts to elected members may only be made in prescribed circumstances Local Government (Administration) Regulations 1996 – <ul style="list-style-type: none">- r.34AC – gifts to council members, when permitted etc.<ul style="list-style-type: none">(1) at least one 4 year term must be completed(2) maximum gift of \$100 per year of service to maximum of \$1,000
--------------------------	---

Corporate context None

History
Adopted 11 October 2016
Last reviewed 24 July 2019
[Last reviewed 7 June 2021](#)

Policy Statement

1. The CEO is to arrange a suitable gift for departing elected members, to the value permitted by the *Local Government (Administration) Regulations 1996* s.34AC, on the basis of –
 - a) \$50.00 per year for each Elected Member,
 - b) an additional \$25.00 per year for each year of service as Deputy President / Mayor,
 - c) an additional \$50.00 per year for each year of service as President / Mayor,
2. Multiple terms of service as a member of Council are to be considered individually according to each period, and not cumulatively.
3. Each departing elected member shall also receive an appropriate plaque or certificate of service.
4. Presentation of the gift and plaque or certificate will generally be made at the final meeting being attended by the elected member, or at a suitable function.
5. Where qualifying, application for a Certificate of Appreciation from the Minister is to be made through the Department of Local Government.

– End of Policy

Notes

Statutory requirement –

Prior to adoption, amendment or revocation to clauses 1, 2 or 3 of this Policy, elected members must –

- **declare a financial interest in accordance with the Local Government Act, and**
- **receive written permission of the Minister for Local Government to participate and vote.**

This Policy is a Financial Interest as defined by the Local Government Act s.5.60 and 5.60A. Exemption from the Minister under s.5.69 is therefore required prior to any amendment, alteration or revocation of the Policy whatsoever.

Although elected members are able to claim meeting fees, travel etc as of right, it is considered appropriate that there be some recognition from the Shire on behalf of the community, for their commitment to the district. Where qualifying, enquiries should also be made through the Department of Local Government and Communities to obtain a Certificate of Appreciation from the Minister

1.4 Public Question Time – Management

- Statutory context**
- Local Government Act 1995 –
 - s.5.24 – requirement for public question time

 - Local Government (Administration) Regulations 1996 –
 - r.5 – meetings where public question time is required
 - r.6 – minimum time for public question time
 - r.7 – procedure for public question time

 - Shire of Narrogin Meeting Procedures Local Law 2016 –
 - cl.6.7 – Other procedures for public question time
 - (1) questioner to state name and address
 - (2) question may be taken on notice
 - (3) if on notice, response to be in writing and a summary in next agenda
 - (4) any interest is to be declared if question is directed to a relevant person
 - (5) two minutes to submit question or questions, unless extended
 - (6) all members of the public to ask their questions before additional questions
 - (7) where submitted in writing, the presiding member may direct it is to be considered as correspondence
 - (8) circumstances in which the presiding member may direct no response is to be given – same question, a statement, offensive or defamatory
 - (9) presiding member may extend public question time, but is not obliged to
 - (10) summary of response to question to be in minutes

Corporate context None

History

Adopted	26 July 2016
Last reviewed	24 July 2019
Last reviewed	7 June 2021

Policy Statement

1. The following Policy Schedules are adopted, and form part of this Statement –
 - 1.4 – Procedure for Public Question Time

2. The Procedures for Public Question Time apply to –
 - a) Ordinary and Special Council meetings,
 - b) Every meeting of Council committees which have a delegated power or duty.

– End of Policy

Notes

Without this Policy, the only controls available to the Presiding Member of a meeting are the provisions of the Act, Regulations and Local Law, all of which allow wide discretion, but offer limited guidance as to processes.

Policy Schedule 1.4 – Public Question Time

PROCEDURE FOR PUBLIC QUESTION TIME

The *Local Government Act 1995* requires that a minimum of 15 minutes be provided at council meetings for public question time. Public question time is early in the meeting as required by the Act. This allows questions to be asked before business is dealt with and also smooth running of the business part of the meeting. The procedure for asking a question is outlined below.

Presenting a question

1. Questions should be addressed to the Presiding Member, and submitted in writing to the Chief Executive Officer by 4.00pm the business day prior to the meeting.
2. Priority will be given to those questions relating to a matter on the Agenda before the meeting. General questions will only be addressed if time permits.
3. The length of question, including any background information, should not exceed 150 words.
4. Questions are limited to 2 per person, and with a total time limit of 2 minutes per speaker. Multiple parts to a question are considered separate questions.
5. Questions are to be directed to the Presiding Member, not to any other person.
6. Questions must be related to issues pertaining to the Shire.
7. Question regarding personal affairs, opinions, information or perceptions not relating directly to Shire business will be refused.
8. Retain your own copy of the question/s to be read aloud at the meeting.
9. No late documentation or item is to be brought into the meeting for distribution without prior arrangement with the CEO.

Managing the questions

10. The CEO is to compile the same or similar questions submitted with notice, and provide a single response.
11. A question without notice at the meeting is to be written on the form available at the meeting so that the exact wording of the question is recorded in the minutes of the meeting. Staff will be made available to assist in wording the question if desired.
12. A timer may be activated at the beginning of each person's time period and the Presiding Member will require questioners to conclude after 2 minutes.
13. Those asking questions are to state their name, address and the item number to which they are referring, and then read the question. Staff will have prepared brief notes to enable an informed response to be given at the meeting.
14. When specifically requested, questioner's details may be kept private.
15. Questions without notice or multiple parts to a question will be answered in the order they are asked to a maximum of 2.
16. Should time permit, after all present have had an opportunity to ask a question, additional questions may be considered.
17. Where a question raises a significant issue not addressed in the staff report, and which cannot be adequately responded to, the meeting will need to consider whether the item should be held over or referred back for further consideration. In making this decision, the meeting will take account of statutory deadlines and other implications if appropriate.

Responding to the questions

18. The order in which questions are to be addressed is –
 - a) questions with notice relating to matters within that meeting's agenda;
 - b) questions with notice relating to other matters;
 - c) questions without notice relating to matters within that meeting's agenda; then
 - d) questions without notice relating to other matters.
19. Matters considered confidential under section 5.23 of the Act will not be addressed other than to advise of such.
20. Written questions submitted by a person not present at the meeting may be declined, and dealt with as correspondence.
21. Responses will be provided in reasonable detail, but in order to permit as many questions as possible, will be concise and to the point. Should greater detail be required, this should be notified to the Shire after the meeting.
22. Questions without notice will only be responded to at the meeting if they are simple. Otherwise they will be taken on notice and will be answered in writing after the meeting and the response included in the agenda of the next council meeting.
23. The meeting will not debate nor discuss the question raised with the questioner. Discussion or debate directly with an elected member or employee, or within the gallery is not permitted.

PLEASE NOTE Members of the public should note that no action should be taken on any item discussed at a council meeting prior to written advice on the resolution of council being received.

– End of Schedule

1.5 Elected Members – Briefing Sessions

Statutory context Local Government Act 1995

Corporate context None

History
Adopted 26 April 2017
Last reviewed 24 July 2019
[Last reviewed 7 June 2021](#)

Policy Statement

1. Briefing Sessions will be held to exchange information between elected members, senior staff, management staff and committees –
 - a) prior to the last Ordinary Council meeting of the month, or
 - b) when called by the President or CEO, as necessary.
2. Briefing Sessions are closed to the general public.
3. The purpose of Briefing Sessions is to –
 - a) provide an opportunity for elected members to request information, ask questions or make comment on specific issues, or on issues in general,
 - b) discuss conceptual issues as considered appropriate by elected members or staff,
 - c) disseminate information from staff to elected members,
 - d) coordinate questions from elected members to staff.
4. Briefing session Information Paper –
 - a) the CEO is to prepare an Information Paper for each briefing session
 - b) the briefing session Information Paper is to be distributed with the Ordinary Council Meeting Agenda, or as able for irregular briefing sessions.
5. Financial, proximity and impartiality interests –
 - a) Elected members, employees, consultants and other participants shall disclose their interests in matters to be discussed
 - b) Interests are to be disclosed in accordance with the provisions of the Act and associated regulations at the time information is provided or discussion commences on an issue.
6. Conduct of Briefing Session –
 - a) the President or other person nominated by the President is to be the Presiding Member for Briefing Session, or in the President's absence another elected member.
 - b) All questions and discussions are to be directed through the Presiding Member and there will be no debate style discussion.
 - c) Being outside the statutory decision making framework, elected members at a Briefing Session must not vote, indicate their voting intentions, make or imply any collective or collaborative decision is to be made, other than the CEO may agree to take an action that is of an administrative nature
 - d) Items listed on the current Council Meeting Agenda may be clarified on matters of procedure or fact, but are not to be debated or resolved/agreed in any way;
 - e) Proposals under a Planning Scheme are not to be discussed.
 - f) Any additional written information not included with the Council Meeting Agenda is only to be distributed to the meeting at the discretion of the Presiding Member.

– End of Policy

Notes

DLGC Operational Guidelines No.5 – Council Forum Guideline is not mandatory but close adherence is recommended.

1.6 Recording of Council Meetings

Statutory context Local Government Act 1995
State Records Act 2000

Corporate context None

History Adopted 26 April 2017
Amended 24 July 2019
[Last reviewed 7 June 2021](#)

Policy Statement

1. Ordinary and Special Meetings of Council may be digitally recorded, consistent with the objectives of the Local Government Act section 1.3(2)(c), which promotes greater accountability of local governments to their communities.
2. Notice advising members of the public of electronic recording of the meeting is to be given by –
 - a) clear signage displayed at each entry to the meeting,
 - b) disclosure to be made in the Agenda for the meeting.
3. Recording is to cease during the period that Council has resolved to close the meeting to members of the public in accordance with section 5.23 of the Local Government Act 1995.
4. Access to the recordings is limited to the CEO and person required to assist in the preparation of the minutes. The recordings are to be used for verifying the accuracy of the minutes, and are not available to elected members, other staff members or members of the public.

– End of Policy

Notes

1.7 Legal Representation for Elected Members and Employees

Statutory context Local Government Act 1995

Corporate context None

History Adopted 26 April 2017
Last reviewed 24 July 2019
[Last reviewed 7 June 2021](#)

Policy Statement

1. The following Council Policy Schedule is adopted, and forms part of this Statement –
1.7 – Legal Costs Indemnification
2. When there is a need for the provision of urgent legal advice before an application can be considered by Council, the amount determined in accordance with Schedule 1.7 clause 3(e) where the CEO may give authorisation is \$10,000.

– End of Policy

Notes

Policy Schedule 1.7 – Legal Costs Indemnification

1. Introduction

This policy is designed to protect the interests of Council members and employees (including past members and former employees) where they become involved in civil legal proceedings because of their official functions. In most situations the Shire may assist the individual in meeting reasonable expenses and any liabilities incurred in relation to those proceedings.

It is necessary to determine that assistance with legal costs and other liabilities is justified for the good government of the district.

2. General Principles

The Shire may provide financial assistance to members and employees in connection with the performance of their duties provided that the member or employee has acted reasonably and has not acted illegally, dishonestly, against the interests of the Shire or otherwise in bad faith.

The Shire may provide assistance in the following types of legal proceedings –

- a) proceedings brought by members and employees to enable them to carry out their local government functions (eg. where a member or employee seeks a restraining order against a person using threatening behaviour);
- b) proceedings brought against members or employees (this could be in relation to a decision of Council or an employee which aggrieves another person (eg. refusing a development application) or where the conduct of a member or employee in carrying out his or her functions is considered detrimental to the person (eg: defending defamation actions); and
- c) statutory or other inquiries where representation of members or employees is justified.

The Shire will not support any defamation actions seeking the payment of damages for individual members or employees in regard to comments or criticisms levelled at their conduct in their respective roles. Members or employees are not prevented, however, from taking their own private action. Further, the Shire may seek its own advice on any aspect relating to such comments and criticisms of relevance to it.

The legal services under this policy will usually be provided by the Shire's solicitors. Where this is not appropriate for practical reasons or because of a conflict of interest then the service may be provided by other solicitors approved by the Shire.

3. Applications for Financial Assistance

- a) Subject to item (e), decisions as to financial assistance under this policy are to be made by the Council.
- b) A member or employee requesting financial support for legal services under this policy is to make an application in writing, in advance if possible, to the Council providing full details of the circumstances of the matter and the legal services required.
- c) An application is to be accompanied by an assessment of the request and a recommendation prepared by the CEO.
- d) A member or employee requesting financial support for legal services, or any other person who might have a financial interest in the matter, must ensure compliance with the financial interest provisions of the Local Government Act 1995.
- e) Where there is a need for the provision of urgent legal services before an application can be considered by Council, the CEO may give an authorisation to the value specified by Council.
- f) Where it is the CEO who is seeking urgent financial support for legal services the Council shall deal with the application.
- g) Any application is to be subject to an enforceable agreement to repay expenses incurred by the Shire, either –
 - In full but not exceeding the extent recovered by a member in accordance with 4(a) below, or
 - In full where 4(2) applies.

4. Repayment of Assistance

1. Any amount recovered by a member or employee in proceedings, whether for costs or damages, will be off set against any moneys paid or payable by the Shire.
2. Assistance will be withdrawn where the Council determines, upon legal advice, that a person has acted unreasonably, illegally, dishonestly, against the interests of the Shire or otherwise in bad faith; or where information from the person is shown to have been false or misleading.
3. Where assistance is so withdrawn, the person who obtained financial support is to repay any moneys already provided. The Shire may take action to recover any such moneys in a court of competent jurisdiction.

– End of Schedule

1.8 Elected Members – Conference, Training, Travel and out of pocket Expenses

Statutory context Local Government Act 1995
Local Government (Administration) Regulations 1996 –
- r.30 – Meeting attendance fees

Corporate context Policy 8.13 – Training, Study and Education

History Adopted 26 April 2017
Amended 24 July 2019
[Last reviewed 7 June 2021](#)

Policy Statement

1. The Shire will meet all reasonable expenses of members incurred whilst attending authorised conferences, seminars and training courses and during other absences from the district on any business authorised by Council or the Chief Executive Officer.
2. Such expenses may include –
 - accommodation,
 - meals,
 - refreshments,
 - travel,
 - other appropriate out-of-pocket expenses subject to budget allocations.
3. Eligible conferences, training, meetings etc
Elected members are to be paid travel costs for the use of private vehicles at the rates determined by the Salaries and Allowance Tribunal Determination each year for any travel to and from Council whilst attending any of the following, as provided by the Regulations r.30 –
 - a) Council meetings (ordinary and special)
 - b) Meetings of Council appointed committees
 - c) Annual and Special Meetings of Electors
 - d) Officially called Civic Receptions
 - e) Visits by Ministers of the Crown
 - f) Council authorised meetings with Government agencies
 - g) Other Council called meetings of Councillors and staff
 - h) Meetings where the elected member is representing the Shire of Narrogin.
4. Accommodation
Expenses automatically met by Council are limited to accommodation in single/twin or double room, registration fees, meals associated with registration, parking and breakfasts for elected members only.
5. Travel
Unless otherwise authorised by Council, travel expenses will only be paid where –
 - a) the elected member is the appointed delegate to the organisation,
 - b) to an appointed deputy delegate, where the delegate is unable to attend, and the deputy is performing functions consistent with the principles of section 5.11A(3) and (4) of the Act.
6. Other expenses
Unless otherwise authorised by Council or the Chief Executive Officer, meals, non-alcoholic refreshments, parking, taxi or other out of pocket expenses will be reimbursed to –
 - a) persons authorised to attend by Council,

- b) delegate appointed by Council to the meeting or organisation,
- c) deputy delegate appointed by Council, only where attending in the place of the appointed delegate.

7. Accompanying person

Only at the WALGA Annual Convention, or similar event where the elected member's partner is reasonably expected to attend, will the reasonable additional costs incurred by a partner accompanying an elected member at that event, such as breakfasts, attending the official conference dinner, official sundowners, or Shire President or CEO convened dinners, be met by the Shire. All other partner costs, such as lunches, partner tours or evening meals not convened with the Shire President or CEO will be met or reimbursed by the elected member or employee.

– End of Policy

Notes

1.9 Elected Member Records – Capture and Management

Statutory context State Records Act 2000
Freedom of Information Act 1992
Local Government Act 1995

Corporate context None

History Adopted 26 April 2017
Amended 24 July 2019
[Last reviewed 7 June 2021](#)

Policy Statement

1. Each elected member is responsible for determining which records are required for capture and management, and submission of the record to the CEO, for storage.
2. The Shire as an organisation, in meeting its obligations to facilitate the capture and management of elected member records will –
 - provide a collection point readily accessible to each elected member to deposit the required materials
 - materials collected will be separated according to elected member and financial year of deposit
 - for electronic records (emails, digital photos etc), a CD suitable for backup of all electronic records will be provided at least once per year,
 - the CD then to be deposited with other required materials,
 - where a copy of the record is to be retained by the elected member, photocopying or other duplicate as necessary, will be provided without charge.
3. Access to the records created may be required, and is to be facilitated by the CEO –
 - as permitted under various legislation such as the Local Government Act, the Freedom of Information Act etc,
 - by order of an authorised body such as the Standards Panel or a Court of law etc,
 - by a representative an authorised body such as the Ombudsman or Crime and Corruption Commission etc.

– End of Policy

Notes

State Records Office policy imposes the obligations on elected members and the organisation under the State Records Act, as advised on 30 July 2009 –

In relation to the recordkeeping requirements of local government elected members, records must be created and kept which properly and adequately record the performance of member functions arising from their participation in the decision making processes of Council and Committees of Council.

This requirement should be met through the creation and retention of records of meetings of Council and Committees of Council of local government and other communications and transactions of elected members which constitute evidence affecting the accountability of the Council and the discharge of its business.

Local governments must ensure that appropriate practices are established to facilitate the ease of capture and management of elected members' records up to and including the decision making processes of Council.

In effect, any form of record which may affect accountability or contribute to a decision or action made as an elected member must be retained. These records may be –

- physical – a letter, a handwritten note, a photo someone sends to an elected member in explanation / complaint, an agenda where you have made notes on various items, etc
- electronic – an email or document sent as an attachment to an email, digital photo, an e-file that is sent for review or comment
- audio – message left on your answering machine, although this is likely to be unusual, since rarely are many details left in a message, but it is a record.

The records are not only those you receive, but also those that you create, such as –

- a note of a conversation where someone asked you to pursue a particular matter,
- a letter that you write in the capacity of elected member,
- an email you send as an elected member

The records only need to be relating to those "*affecting the accountability of the Council and the discharge of its business ... up to and including the decision making processes of Council*". It is the elected members decision and judgement as to what extent this applies, *and it is suggested that this not be further defined.*

The principles of relevance and ephemerality apply, for example –

- a note to remind you to phone a person is ephemeral, but notes of the conversation may not be,
- a copy of an agenda that has no notes made is irrelevant, as the document can be reproduced by the Shire at any time,
- a promotional brochure or conference information is not relevant

1.10 Related Party Disclosures (AASB 124)

Statutory context Local Government (Financial Management) Regulations 1996 -

- r.4 – AAS to be complied with and has priority over Regulations
- r.5 – annual budget, annual financial report and other financial reporting to be in accordance with AAS
- Sch.2 Form 1 – CEO required to certify annual financial reports complied in accordance with AAS

Local Government (Audit) Regulations 1996 –

- r.9 – audit is to be performed in accordance with AAS

Australian Accounting Standard 124 – Related Party Disclosures

Corporate context Annual Report Requirements

History

Adopted	28 June 2017
Amended	24 July 2019
Last reviewed	7 June 2021

Policy Statement

1. Policy Schedules adopted

The following Council Policy Schedules are adopted, and form part of this Statement –

1.10 – Related Party Disclosures – Definitions

2. Application

This Related Party Disclosures Policy applies to –

- a) Related Parties of Council,
- b) Key Management Personnel.

3. Disclosure requirement

- (a) The disclosure requirements apply to the existence of relationships regardless of whether a transaction has occurred or not.
- (b) Each financial year, the Shire must make an informed judgement as to who is a related party and what transactions need to be considered, when determining if disclosure is required.

4. Key Management Personnel (KMP)

In accordance with AASB 124, KMP are –

- All elected members
- CEO
- Executive Manager –
 - o Corporate & Community Services
 - o Development & Regulatory Services
 - o Technical & Rural Services
- Manager –
 - o Finance
 - o Operations
 - o Community Care Services
 - o Library Services
 - o Community Leisure and Culture

5. Related Party – Council

- (a) Related entities to Council are those where the Shire of Narrogin has significant control or influence, which is deemed to be a greater than 20% –
- financial interest in the organisation,
 - voting rights in the organisation.
- (b) Unless otherwise excluded, the administration will be required to assess all transactions made with these persons or entities.

6. Related Party – KMP

- a) Related parties of the KMP are close family members of the KMP.
- b) For the AASB 124, close family members could include extended family members (such as, parents, siblings, grandparents, uncles/aunts or cousins) if they could be expected to influence, or be influenced by, the KMP in their dealings with the Shire.
- c) Related entities to the KMP or close family members are those where the person has control, joint control or influence, which is deemed to be greater than 20% –
- financial interest in the organisation
 - voting rights in the organisation.
- d) Unless otherwise excluded, the administration will be required to assess all transactions made with these persons or entities.

7. Related Party Transactions (RPT)

- (a) A related party transaction is a transfer of resources services or obligations between the Shire (reporting entity) and the related party, regardless of whether a price is charged.
- (b) For the purposes of determining whether a related party transaction has occurred, the following transactions or provisions of services have been identified as meeting this criterion –
- (i) payments to elected members;
 - (ii) employee compensation whether it is for KMP or close family member of KMP.
 - (iii) lease agreements for housing rental (whether for a Shire owned property or property sub-leased by the Shire through a real estate agent)
 - (iv) lease agreements as lessee or lessor, for commercial properties or other properties;
 - (v) monetary and non-monetary transactions between the Shire and any business or associated entity owned or controlled by the related party (including family) in exchange for goods and/or services provided by/to the Shire (trading arrangement).
 - (vi) loan arrangements between related entities or KMP;
 - (vii) contracts and agreements for construction, consultancy or services
 - (viii) purchases or sales of goods; property and other assets;
 - (ix) rendering or receiving of services; or goods;
 - (x) transfers under licence agreements; or finance arrangements (example, loans);
 - (xi) provision of guarantees (given or received);
 - (xii) commitments to do something if an event occurs, or does not occur, in the future;
 - (xiii) settlement of liabilities on behalf of Council or by the Shire on behalf of that related party;
 - (xiv) use of Shire owned facilities and public open spaces, if a fee is normally charged and the KMP are not.

8. Ordinary Citizen Transactions (OCT)

- a) OCT are where there is no special treatment or consideration of either party and are deemed to be any transaction that a member of the public would receive in the usual course of business, and includes but is not limited to –
- (i) payment of rates and charges imposed by Budget resolution, fines and penalties etc.
 - (ii) payment of application or development fees imposed by Council and applying to any applicant
 - (iii) use of Council facilities, whether use of the facility incurs a fee or not, and includes Recreation Centre, Civic Centre, library, parks, ovals, reserves, waste facility and public open spaces
- b) OCT incorporates transactions resulting from delivery of Public Service Obligations and includes but is not limited to –

- (i) attending Shire of Narrogin functions that are open to the public
 - (ii) attending events that are open to the public
- (c) All Ordinary Citizen Transactions identified within this policy are unlikely to influence the conclusions that those reading the Shire's financial statements would make.

9. Materiality

For guidance, materiality is generally deemed to apply where –

- Where an RPT can be expressed in financial terms
 - o Single transaction – greater than \$300
 - o Cumulative transactions – greater than \$1,500
- Where an RPT cannot be expressed in financial terms –
 - o reasonable person test – would an ordinary person consider that pressure has been applied or influence exerted

10. Related Party Notification

- a) KMP must submit to the CEO a Related Party Declaration, notifying of any existing or potential related party relationship between Council and either themselves, their close family members or entities controlled or jointly controlled by them or any of their close family members.
- b) Related Party Declarations are to be submitted –
 - (i) within 30 days of commencement;
 - (ii) annually, prior to 31 August;
- c) Related Party Declarations are to be updated where –
 - (i) any new or potential related party transaction that is required or likely to be required to be disclosed in Council's financial statements; or
 - (ii) any change to a previously notified related party transaction.

11. Related Party Transaction Notification

- a) A related party transaction is a transfer of resources, services or obligations between the Shire (reporting entity) and the related party, regardless of whether a price is charged.
- b) KMP must submit to the CEO a Related Party Transaction Notification, notifying of any transaction between Council and either themselves, their close family members or entities controlled or jointly controlled by them or any of their close family members.
- c) Related Party Transaction Notifications are to be submitted –
 - (i) at minimum – within 30 days of the end of each financial year;
 - (ii) recommended – at Council meeting each month, and
 - (iii) when leaving the Shire as an elected member or cessation of employment.

12. Confidentiality

- (a) All information contained in a disclosure return, will be treated in confidence.
- (b) Generally, related party disclosures in the annual financial reports are reported in aggregate and individuals not specifically identified.
- (c) Notwithstanding, management is required to exercise judgement in determining the level of detail to be disclosed based on the nature of a transaction or collective transactions and materiality. Individuals may be specifically identified, if the disclosure requirements of AASB 124 so demands.

13. Discretionary capacity of the CEO

Where a matter is not covered by this policy, the CEO is authorised to make a determination, and may seek such advice as is necessary in order to do so.

– End of Policy

Notes

Abbreviations –

AASB – Australian Accounting Standards Board
KMP – Key Management Personnel
OCT – Ordinary Citizen Transaction
RPT – Related Party Transaction

The objective of the AASB is to ensure that an entity's financial statements contain disclosures necessary to draw attention to the possibility that its financial position and profit or loss may have been affected by the existence of related parties and transactions.

The disclosure requirements apply to the existence of relationships regardless of whether a transaction has occurred or not. For each financial year, the Shire must make an informed judgement as to who is a related party and what transactions need to be considered, when determining if disclosure is required.

Effective beginning 1 July 2016 the Shire must disclose in the Annual Report certain related party relationships and transactions together with information associated with those transactions in its Financial Statements, to comply with Australian Accounting Standard 124 Related Party Disclosures.

If there is a related party transaction with the Shire applicable to a reporting financial year, the AASB 124 requires the Shire to disclose in the financial statements the nature of the related party relationship and information about the transaction, including outstanding balances and commitments associated with the transaction. Disclosure in the financial statements may be in the aggregate and/or made separately, depending on the materiality of the transaction.

For more information about the Shire's disclosure requirements under the AASB 124, please refer to <http://www.aasb.gov.au>

Forms

Form FCEO039 Related Parties Declaration to be completed by KMPs to make the notification.

Policy Schedule 1.10 – Related Party Disclosures – Definitions

ALBT or arm's length business transaction means a transaction where the terms between parties are reasonable in the circumstances of the transaction that would result from –

- (a) neither party bearing the other any special duty or obligation; and
- (b) the parties being unrelated and uninfluenced by the other, and
- (c) each party having acted in its own interest

associate means relation to an entity (the first entity), an entity over which the first entity has significant influence.

close members of the family of a person means relation to a key management person, family members who may be expected to influence, or be influenced by, that key management person in their dealings with the Shire and include –

- (a) that person's children and spouse or domestic partner;
- (b) children of that person's spouse or domestic partner; and
- (c) dependants of that person or that person's spouse or domestic partner.

control means the ability to direct the business' activities of an entity through rights or exposure to returns from its involvement with the entity.

entity can include a body corporate, a partnership or a trust, incorporated association, or unincorporated group or body or non-profit association.

financial benefit includes giving a financial benefit indirectly through an interposed entity, making an informal, oral or non-binding agreement to give the benefit, and giving a benefit that does not involve paying money.

Examples of "giving a financial benefit" to a Related Party include but are not limited to the following –

- (a) Giving or providing the Related Party finance or property.
- (b) Buying an asset from or selling an asset to the Related Party.
- (c) Leasing an asset from or to the Related Party.
- (d) Supplying services to or receiving services from the Related Party.
- (e) Issuing securities or granting an option to the Related Party.
- (f) Taking up or releasing an obligation of the Related Party.

joint control is the contractually agreed sharing of control of an arrangement, which exists only when decisions about the relevant activities require the unanimous consent of 2 or more parties sharing control.

joint venture is an arrangement of which 2 or more parties have joint control and have right to the net assets of the arrangement.

KMP or key management personnel or Key management person are those person(s) having authority and responsibility for planning, directing and controlling the activities of Council.

KMP compensation all forms of consideration paid, payable, or provided in exchange for services provided.

material is the assessment of whether the transaction, either individually or in aggregate with other transactions, by omitting it or misstating it could influence decisions that users make on the basis of an entity's financial statements. For this policy, it is not considered appropriate to set either a dollar value or a percentage value to determine materiality.

OCT or ordinary citizen transaction are transactions that an ordinary citizen would undertake with Council, which is undertaken on arm's length terms and in the ordinary course of carrying out Shire's functions and activities.

related party is a person or entity that is related to the Shire or KMP pursuant to the definition contained in the AASB 124 –

- (a) an entity that is controlled, jointly controlled or significantly influenced by the Shire or KMP;
- (b) close family members of the KMP; or
- (c) an entity controlled, jointly controlled or significantly influenced by a close family member of the KMP.

RPT or related party transaction means a transfer of resources, services or obligations between the Shire and a related party, regardless of whether a price is charged.

significant means likely to influence the decisions that users of the Shire's financial statements make having regard to both the extent (value and frequency) of the transactions, and that the transactions have occurred between the Shire and related party outside a public service provider/ taxpayer relationship.

remuneration or remuneration package and includes any money, consideration or benefit received or receivable by the person but excludes reimbursement of out-of-pocket expenses, including any amount received or receivable from an RPT.

– End of Schedule

1.11 Common Seal

Statutory context

Local Government Act 1995 –

s.2.5(2) – the local government is a body corporate with perpetual succession and a common seal

s.9.49A – Execution of documents

s.9.49 – Documents, how authenticated

Corporate context

Delegations Register –

2.1 Common Seal – Execution of documents

History

Adopted 24 July 2019

[Last reviewed 7 June 2021](#)

Policy Statement

1. The common seal of the Shire is –



2. Local Government Act 1995 section 9.49A –

(2) *The common seal of a local government is not to be affixed to any document except as authorised by the local government.*

(3) *The common seal of the local government is to be affixed to a document in the presence of —*

(a) the mayor or president; and

(b) the chief executive officer or a senior employee authorised by the chief executive officer, each of whom is to sign the document to attest that the common seal was so affixed.

Procedures

Common Seal Register

Forms and Templates

Nil

– End of Policy

Notes

1.12 Internal Control

Statutory context

All legislation, regulations and local laws

Corporate context

[Policy Manual –](#)

[3.10 – Portable and Attractive Assets](#)

[12.11 – Asset Management](#)

Deleted: None ¶

History

Adopted 24 July 2019

[Reviewed 7 June 2021](#)

Policy Statement

The Internal Controls Policy serves as evidence of Council's commitment to proper and effective internal controls and their significance to the organisation.

This policy provides a basis for establishing documented internal controls that are implemented based on risk management policies and standards.

The policy ensures that Council meets its obligations under the Local Government Act 1995, related Regulations and other legislation.

The policy will aid the organisation to address the risks as outlined under the objectives.

1. The purpose of this policy is to assist the Shire to carry out its activities in an efficient and effective manner in order to achieve its strategic objectives, to ensure adherence to policies, to safeguard the Shire's assets, and to secure (as far as possible) the accuracy and reliability of Shire financial records.
2. This policy applies to all aspects of the Shire of Narrogin operations.
3. This policy documents Council's commitment to appropriate and effective internal controls and their importance to the organisation.
4. This policy provides a framework for the establishment of documented internal controls that are implemented based on risk management policies and principles.
5. The policy will assist the organisation in addressing the risk of; material misstatement of financial information, fraud and corruption, misappropriation of funds and loss of physical assets and ensure that Council meets its obligation under the *Local Government Act 1995*, associated Regulations and other legislation.
6. Internal Control –
Systems of policies and procedures that safeguard assets, ensure accurate and reliable financial reporting, promote compliance with laws and regulations and achieve effective and efficient operations. These systems not only relate to accounting and reporting but also include communication and organisational processes both internally and externally, staff management and error handling.
7. Principles –
 - a) A risk based approach to address and reduce the risk of loss caused by fraud, error or misstatement.
 - b) Protection of the Shire of Narrogin's assets – people, property, reputation, financial sustainability and information.
 - c) On-going audit and identification of system gaps and improvement of internal controls at the Shire of Narrogin.
8. Roles and Responsibilities –

- a) An appropriate and effective internal control framework is the responsibility of all employees.
 - b) All employees are accountable for implementing systems, controls, processes and procedures in their own area of responsibility and will play a part in the internal control framework in differing degrees.
 - c) The Audit Committee and Council are responsible for mandating that a strong internal control framework is implemented to ensure the good governance of the organisation.
 - d) The Chief Executive Officer will report at least three yearly to the Audit Committee and Council on the review and improvement to Council's internal control framework.
9. Monitoring, Reviewing and Reporting –
A monitoring and reporting process/system will be implemented which will provide at least three yearly reports to management, the Audit Committee and Council on the status of Risk Management, Internal Controls and Legislative Compliance within the Shire and which will identify the need for specific areas for review.

In accordance with Regulation 17 of the *Local Government (Audit) Regulations 1996*, the Chief Executive Officer is required to report on a review of the above three areas every three years. This is in addition to the three-yearly review required by Regulation 5(2)(c) of the *Local Government (Financial Management) Regulations 1996* which also includes a review of the Shire's financial internal controls.

Procedures

Forms and Templates

Nil

– End of Policy

Notes

1.13 Legislative compliance

Statutory context

All legislation, regulations and local laws

Corporate context

None

History

Adopted 24 July 2019

[Last reviewed 7 June 2021](#)

Policy Statement

A fundamental principle of good public administration is that public officials comply with both the letter and the spirit of the law.

The Shire of Narrogin has an obligation to ensure that legislative requirements are complied with. The community and those working at the Shire have an expectation that the Council will comply with applicable legislation and the Council should take all appropriate measures to ensure that that expectation is met.

Regulation 14 of the Local Government (Audit) Regulations 1996 requires local governments to carry out a compliance audit for the period 1 January to 31 December in each year. The compliance audit is structured by the Department of Local Government, Sporting and Cultural Industries and relates to key provisions of the Local Government Act 1995.

Regulation 17 of the Local Government (Audit) Regulations 1996 also requires a review of the appropriateness and effectiveness of systems and procedures in relation to legislative compliance at least once every three financial years and a report to the Audit Committee on the results of that review.

1. The Shire will have appropriate processes and structures in place to ensure that legislative requirements are achievable and are integrated into the operations of the local government.
2. The processes and structures will aim to –
 - a) Develop and maintain a system for identifying the legislation that applies to the Shire's activities.
 - b) Assign responsibilities for ensuring that legislation and regulatory obligations are fully implemented.
 - c) Provide training for relevant employees, elected members, volunteers and other relevant people in the legislative requirements that affect them.
 - d) Provide people with the resources to identify and remain up-to-date with new legislation.
 - e) Establish a mechanism for reporting non-compliance.
 - f) Review accidents, incidents and other situations where there may have been non-compliance.
 - g) Review audit reports, incident reports, complaints and other information to assess how the systems of compliance can be improved.
3. Roles and Responsibilities
 - a) Elected members and committee members –
Elected members and committee members have a responsibility to be aware and abide by legislation applicable to their role.
 - b) Senior management –
Senior management should ensure that directions relating to compliance are clear and unequivocal and that legal requirements which apply to each activity for which they are responsible are identified. Senior Management should have systems in place to ensure that all staff are given the opportunity to be kept fully informed, briefed and/or trained about key legal requirements relative to their work within the financial capacity to do so.
 - c) Employees –
 - i) Employees have a duty to seek information on legislative requirements applicable to their area of work and to comply with the legislation.

- ii) Employees shall report through their supervisors to Senior Management any areas of non-compliance that they become aware of.
4. Implementation of Legislation
The Shire will have procedures in place to ensure that when legislation changes, steps are taken to ensure that future actions comply with the amended legislation.
5. Legislative Compliance Procedures
- a) Identifying Current Legislation –
The Shire accesses electronic up to date versions of legislation through the Department of Justice Parliamentary Counsel's Office website at www.legislation.wa.gov.au. Direct access to this site is provided from the Shire's networked computers.
 - b) Identifying New or Amended Legislation –
 - i) Western Australian Government Gazette
The Government Gazette publishes all new or amended legislation applicable to Western Australia. Copies of Government Gazettes are able to be downloaded from the State Law Publisher website at slp.wa.gov.au. It is incumbent on the CEO and Senior Staff to determine whether any gazetted changes to legislation need to be incorporated into processes.
 - ii) Department of Local Government, Sporting and Cultural Industries –
The Shire receives regular circulars from the Department on any new or amended legislation. Such advice is received through the Shire's Records section and is distributed to the CEO and relevant Shire officers for implementation.
 - iii) Department of Planning, Lands and Heritage (DPLH) –
The Shire receives Planning Bulletins from DPLH on any new or amended legislation. Such advice is received through the Shire's Records section and is distributed to the relevant Shire officers for implementation.
 - iv) Western Australian Local Government Association (WALGA) –
The Shire receives regular circulars from WALGA and these circulars highlight changes in legislation applicable to local governments.
 - c) Obtaining advice on Legislative Provisions
The Shire will obtain advice on matters of legislation and compliance where this is necessary. Contact can be made with the Department of Local Government, Sporting and Cultural Industries, WALGA or the relevant initiating government department for advice.
 - d) Informing Council of legislative change
 - i) If appropriate the CEO will, on receipt of advice of legislative amendments, advise the Council on new or amended legislation.
 - ii) The Council's format for all its reports to Council meetings provides that all reports shall have a section headed 'Statutory implications' which shall detail the sections of any Act, Regulation or other legislation that is relevant.
6. Review of Incidents and Complaints of Non-compliance
The CEO shall review all incidents and complaints of non-compliance. Such reviews will assess compliance with legislation, standards, policies and procedures that are applicable.
7. Reporting of Non-compliance
- a) All instances of non-compliance shall be reported immediately to the supervising Executive Manager.
 - b) The Executive Manager shall determine the appropriate response and then report the matter to the CEO.
 - c) The CEO may investigate any reports of significant non-compliance and if necessary report the non-compliance to the Council and/or the relevant government department.
 - d) The CEO will also take the necessary steps to improve compliance systems.

Procedures

Compliance Calendar

Forms and Templates

Nil

– End of Policy

Notes

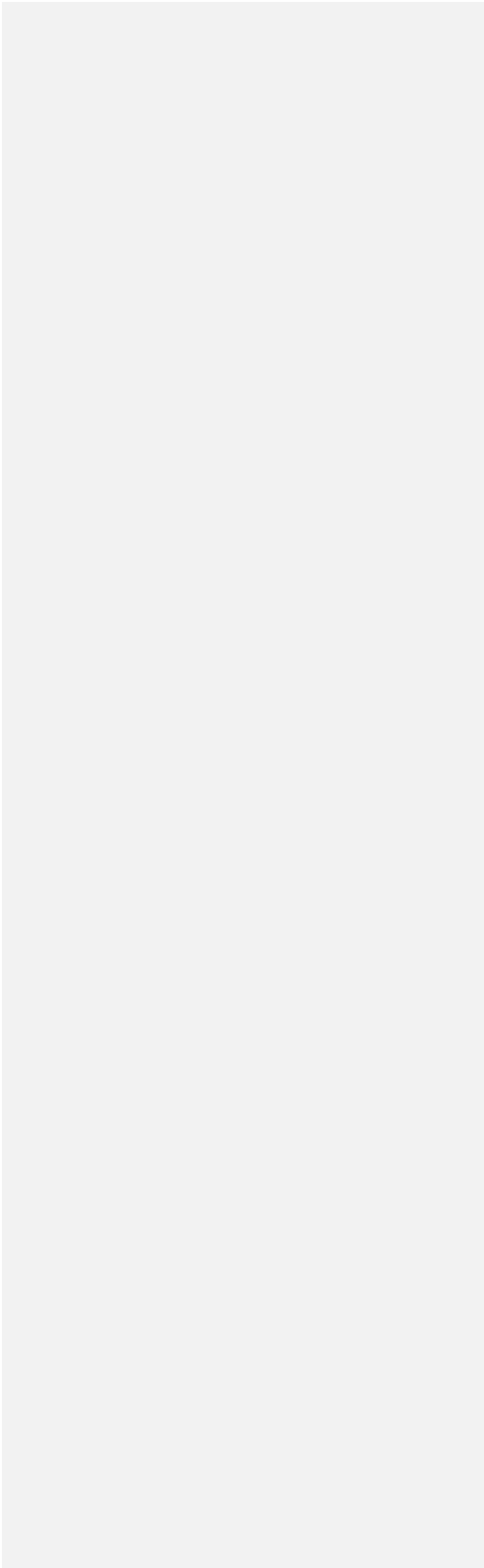

1.14 Community Engagement Policy

Statutory context

Local Government Act 1995 –
s.2.7 – adoption of policies
Integrated Planning and Reporting Guide and Framework

Corporate context Nil

History Adopted 25 September 2019
[Last reviewed 7 June 2021](#)

Policy statement

This policy outlines the purpose, principles and approach to community engagement to be taken by the Shire of Narrogin when engaging communities and stakeholders.

The policy will be applied by all employees and consultants appointed by the Shire when engaging those affected by and interested in decisions to be made by the Shire.

1. Purpose

The Shire of Narrogin is committed to providing opportunities for all members of the community to participate in civic decision-making processes.

The Shire recognises that the community is a source of knowledge and expertise, and this can be harnessed to help find solutions to local issues as well as complex Shire challenges.

Community engagement is a key part of our commitment to be a transparent and responsive organisation. Our objective is to make better decisions by giving a voice to communities and stakeholders on matters and topics that are of interest and important to them and to develop and encourage a culture which respects and welcomes community input.

2. Principles

The Shire of Narrogin's approach to community engagement is guided by the following principles:

2.1 We clearly communicate why we are engaging and the community's role in the engagement.

From the outset, we articulate the purpose of our engagement and what will happen as a result of any information gathered. We explain what level of influence the community, stakeholders and Council have on the decision to be made, and any associated limitations or constraints. We consider the requirements for each project and its level of potential impact on the community to determine the required level and timing of engagement. We provide all information necessary so participants can make informed choices.

2.2 We carefully consider who to engage.

Before we begin engaging, we identify communities and stakeholders who are directly involved, or likely to be affected by the project. On major projects that set a direction or define a position for the Shire, we encourage broad community participation to ensure that a diverse range of views and ideas are expressed and considered. We also consider barriers that prevent or deter people from participating in engagement activities and consider ways to minimise them.

2.3 We explain the process.

We aim to be transparent, and make our decision-making process clear. We do this by explaining upfront the process to be undertaken, identifying where there is opportunity for the community and stakeholders to have input, and where the decision-points are.

Where possible, we build on the outcomes of previous engagement. If the engagement crosses over with a previous engagement process, we explain the outcomes, identify how they relate to the current process and why a new process is required.

2.4 We carefully consider how to engage and ensure our processes, venues and information are accessible.

We recognise people engage with civic life in different ways depending on a number of factors, such as age, background and ability. We aim to be responsive to this broad spectrum of needs, and ensure there are multiple engagement methods in various settings, to achieve appropriate community participation.

We ensure our engagement is accessible by providing information in clear and easy to understand formats, or is available in alternative formats on request. Our engagement events and venues are designed to be accessible whenever practical and achievable.

2.5 We design our engagement to be engaging.

The Shire of Narrogin is working to continuously improve how we engage, and design approaches that are creative, relevant and engaging. We are open to new and innovative engagement methodologies, and we are working on ways to tailor our approach to draw people into the process and maximise the reach and impact of our engagement.

2.6 We complement our engagement with high quality communication.

We provide clear, comprehensive and accessible information, written in plain English, to stakeholders throughout the engagement process. Information about our engagement is available at Have Your Say on our website (<https://www.narrogin.wa.gov.au/have-your-say.aspx>) and through the Shire's usual communication channels.

2.7 We acknowledge contributions made during the engagement process and let participants know how their feedback was used in our decision-making.

We are transparent with the community about how their participation was considered, by reporting back what we heard from contributors and how their input has been incorporated in decision making. We share the results of engagement through Have Your Say - (<https://www.narrogin.wa.gov.au/have-your-say.aspx>)

We also advise contributors when the matter is to be considered by Council so they may attend Ordinary Council Meetings if they wish.

3. Approach

3.1 When we engage

The Shire will engage with the community when:

- Council resolves formally to engage.
- A decision or plan will substantially impact the community and there is some part of the decision or plan that is negotiable.
- Stakeholders or the community have expressed an interest, or could be interested in a decision or plan where there is a range of potential outcomes.
- Community input can enhance decision-making, project outcomes or future opportunities.
- There is legislation, policy or an agreement requiring community engagement or consultation.

3.2 How we engage

The level of engagement will vary depending on the nature and complexity of the project or decision and will be guided by the Shire of Narrogin community engagement principles as set out above in Section 2 of this Policy.

Consideration is given to matters like community and stakeholder interest, political sensitivity, opportunities for partnerships, the level of impact, legislative requirements, time and resource and budget constraints. These considerations will guide how and when in the life of a project or decision community engagement may offer the greatest benefit.

Quality community engagement is well planned and executed, inclusive and accessible to all members of the community.

At times Council will engage the community on issues that are of importance or interest to a specific part of the community. In this instance, engagement will be targeted towards this group.

The Shire's engagement approach has four stages to ensure we deliver a consistent approach to engagement activities. This includes: a process of planning (developing an engagement plan); doing (preparing and engaging); reporting (analysing information and providing updates on the engagement) and evaluating (both the process and outcomes).

The purpose of the engagement and the type of input that will assist with the decision to be made, is reflected in the way community engagement is planned and reported. We carefully consider aspects of both qualitative input (such as trends and thoughts) and quantitative input (such as number of participants) when designing engagement methods and reporting back what we heard.

The following matrix is used to assist in determining the most suitable approach, relative to the likely 'level of impact' of a project, plan, service or action. As highlighted by this matrix, there are four levels of engagement: Inform, Consult, Involve, and Collaborate. More than one level of engagement is generally required, as there is likely to be movement back and forth through the different levels as the engagement is implemented, except in the case of projects or issues with only a low level of impact of a localised nature or if there is a statutory requirement to consult (see 3.4).

Expected level of impact	Criteria (one or more of the following)	Engagement approach generally taken	Level of engagement generally required	Examples of engagement methods the Shire may use
High – Shire wide	High level of impact on all or a large part of the Shire of Narrogin.	Early engagement with community and stakeholders.	Inform	Mail drop
		Involves a broad range of stakeholders and community members.	Consult	Media Releases
	Any significant impact on attributes that are considered to be of high value to the whole of the Shire, such as the natural environment or heritage.	Utilises a variety of engagement methods to give people who want to contribute, the opportunity to do so.	Involve	Narrogin Narrative
		Updates are provided to interested stakeholders and local community.	Collaborate	Website
	Likely high level of interest across the Shire.	Engagement plan developed in collaboration with the relevant departments and approved by the Chief Executive Officer.		Email
	Potential high impact on state or regional			Social Media
			Direct contact with critical stakeholders	
			Focus groups	

	strategies or directions.	Budget allocated to deliver community engagement. Process is evaluated to assess the quality and overall effectiveness of the engagement and assist the Shire's commitment to continually improve our engagement practice.		Workshops Working group Surveys Online tools on Have Your Say Face to face at engagement events Pop ups at community events and spaces Feedback and submission forms
High – Local	High level of impact on a local area, small community or user group(s) of a specific facility or service. Significant change to any facility or service to the local community. Potential for a high degree of community interest at the local level.	May range from seeking comment on a proposal to involving the community and stakeholders in discussion on proposed options. Comprehensive information is made available to the community to enable informed input. Uses a combination of face to face and online engagement methods to encourage broad participation at different levels. Feedback is collated and made available to all stakeholders. Updates are provided to interested stakeholders and local community.	Inform Consult Involve	Mail drop Media Releases Narrogin Narrative Surveys Online tools on Have Your Say Direct contact with critical stakeholders Face to face at engagement events Pop ups at community events and spaces Feedback and submission forms
Low – Shire wide	Lower level of impact across the Shire. Level of interest among various communities or stakeholder groups.	Approach may range from seeking comment on a proposal to involving the community and stakeholders in discussion and debate on proposed options. Ensures informed input through making comprehensive information available to the community.	Inform Consult Involve	Mail drop Media Releases Narrogin Narrative

	Potential for some, although not significant, impact on state or regional strategies or directions.	Uses a combination of face to face and online engagement methods to encourage broad participation at different levels. Feedback is collated and made available to all stakeholders. Updates are provided to interested stakeholders and local community.		Website Email Social Media Surveys Online tools on Have Your Say Face to face at engagement events Pop ups at community events and spaces Feedback and submission forms
Low - Local	Lower level of impact on a local area, small community or user group of a specific facility or service. Only a small change to a facility or service at the local level. Low interest at the local or user group level.	Approach consists of advising the community or stakeholders of a situation or proposal or informing of a decision or direction. Communication strategy that provides high quality, accessible information to those affected by and interested in the change or decision. Communication channels relevant to the target audience are used.	Inform	Mail drop Media Releases Narrogin Narrative Website Email Signage Social media Advertising

3.3 When it is not effective or appropriate to engage

It is neither effective nor appropriate for the Shire to engage when:

- A final decision has already been made by council or another agency.
- Council cannot influence a decision by another agency or party.
- The decision to be made concerns a minor operational matter with minimal impact on the community or stakeholders.
- Implementing a project or decision that has already been subject to engagement.
- There is insufficient time due to legislative or legal constraints, or urgent safety issues to be addressed.

In these events, the Shire will inform stakeholders why the decision has been made.

3.4 Statutory engagement

In some instances, the Shire of Narrogin is legally required to consult with the community. In these cases, the Shire will treat the prescribed level of community engagement as the minimum standard.

The most common instance of this is in relation to development applications and other planning proposals. For planning proposals, the Shire relies on its policies, adopted under the Planning and Development Act 2005, for guidance in regard to consultation and this will continue to be the basis on which the Shire engages with the community on planning matters.

Delivery of community engagement beyond legally required levels will depend on the decision to be made (or project or service to be delivered), the community's interest to participate, the need for Council to understand the community's view, and the opportunity for the community to influence the decision.

3.5 Holiday periods and other seasonal times

The Shire will not commence an engagement process between the last Council meeting of the calendar year and the first Council meeting of the new-year, unless there is a legal requirement, Council direction or other unavoidable necessity to do so.

An additional 14 days will be added to any engagement period that falls between 15 December and 15 January and 7 days before and 7 days after Easter Sunday.

The Shire will be cognisant of not commencing an engagement process where the primary identified stakeholders and communities would seasonally, or culturally, be less likely to make comment.

Definitions and abbreviations

Engagement – The practice of actively bringing community voices into decisions that affect or interest them, using a range of methods.

Consultation – Seeking and receiving feedback or opinion, usually on a proposed plan or decision, e.g. seeking comment on a draft policy or concept.

Community – A general term for individuals and groups of people not part of an organised structure or group. They may be a community based on geography, or interest, or both, e.g. residents of Highbury, young people interested in skateboarding. The community is not restricted to ratepayers or residents of the Shire of Narrogin.

Stakeholders – People who are organised under the banner of a defined group or organisation, often providing representation to a broader group, e.g. Narrogin Chamber of Commerce, a local school or sporting group.

Engagement tools/methods – The things we use to activate community input, e.g. an invite for public comment, a workshop, an online survey, a community meeting.

Level of engagement – Refers to any one of five levels of engagement (inform, consult, involve, collaborate, empower) defined by the International Association of Public Participation (IAP2) Public Participation Spectrum to describe the community's role in any engagement programme. A complete description of the IAP2 Public Participation Spectrum can be found online at www.iap2.org.

Procedures

Forms and Templates

– End of Policy

Notes

1.15 Elected Member and Chief Executive Officer Attendance at Events Policy

Statutory context Local Government Act 1995 –
- [s.5.51A – Code of conduct for employees required to be prepared and implemented by CEO](#)
- Section 5.90A – requirement to prepare and adopt a policy [for Council members and the CEO](#)

Corporate context Council Policy Manual –
- 1.1 Code of Conduct
- 1.8 Elected Members – Conference, Training, Travel and out of pocket Expenses
- 8.13 Training, Study and Education

[Code of Conduct – Employees](#)

History Adopted 25 February 2020
[Last reviewed 7 June 2021](#)

Policy Statement

Objective

The Shire of Narrogin is required under the Local Government Act 1995 to adopt a policy on attendance at events for Elected Members and the Chief Executive Officer.

This policy applies to Elected Members, the Chief Executive Officer and all employees of the Shire of Narrogin (the Shire) in their capacity as an Elected Member or employee of the Shire and where they may receive free or discounted tickets or invitations to attend events to represent the Shire to fulfil their leadership roles in the community, generally, from a third party.

Attendance at an event, in accordance with this policy, will exclude a gift recipient from the requirement to disclose a potential conflict of interest if the ticket is above \$300 (inclusive of GST) and the donor has a matter before Council. Any gift received that is \$300 or less (either one gift or cumulative over 12 months from the same donor) also does not need to be disclosed as an interest.

Notations

- If an Elected Member receives a ticket in their name, in their role as an Elected Member, of \$300 or greater value, they are still required to comply with normal gift disclosure requirements.
- Whilst the law permits gifts greater than \$300 to be accepted by the Chief Executive Officer (but not other employees), in their role with the Shire, the Chief Executive Officer and all other employees, by operation of this Policy, are prohibited from accepting any gift greater than \$300, unless from the Shire as the organiser of the event, or as a gift pursuant to Section 5.50 of the Local Government Act 1995 (gratuity on termination).
- If the Chief Executive Officer or an employee receives a ticket in their name, in their role as an employee, of between \$50 and \$300, they are required to comply with normal gift disclosure requirements and the Code of Conduct re notifiable and prohibited gifts.
- An event does not include training, which is dealt with separately via Policies 1.8 Elected Members – Conference, Training, Travel and out of pocket Expenses or 8.13 Training, Study and Education.
- Nothing in this Policy shall be construed as diminishing the role of the Chief Executive Officer in attending or approving attendance at activities or events by other employees, that in the opinion of the CEO, are

Deleted: ,

Deleted: and Employee

Deleted: ¶

Local Government (Administration) Regulations 1996 – ¶
- r.34B – required code of conduct contents about gifts to employees ¶
¶

appropriate, relevant and beneficial to the Shire of Narrogin and its employees as long as it does not involve gifted or discounted attendance fees.

Definitions

District: is defined as the Wheatbelt Region of Western Australia.

Elected Members: includes the Shire President and all Councillors.

Shire: is the local government of the Shire of Narrogin.

In accordance with Section 5.90A of the Local Government Act 1995, an event is defined as a:

- Concert
- Conference
- Function
- Sporting event
- Occasions prescribed by the Local Government (Administration) Regulations 1996.

Acronyms

- CEO - Chief Executive Officer
- GST - Goods & Services Tax
- LGIS - Local Government Insurance Services
- WALGA - Western Australian Local Government Association

1. Permitted Events

All Elected Members, the Chief Executive Officer and employees with the approval of the CEO or their respective Executive Manager, are entitled to attend permitted events to assist represent the Shire of Narrogin.

If there is a fee associated with a permitted event, the fee, including the attendance of a partner, and if deemed necessary, travel and accommodation, may be paid for by the Shire out of the Shire's budget by way of reimbursement, unless the event is a conference which is dealt with under clause 4 of this policy.

If there are more Elected Members than tickets provided then the Shire President shall allocate the tickets.

Note well: Donated or Discounted individual tickets and any associated hospitality with a discount / donated estimated or face value above \$500 (inclusive of GST and if relevant, travel) provided to the Shire are to be referred to Council for determination.

The following events are permitted subject to the provisions of this policy:

- a. Advocacy, lobbying or Members of Parliament or Ministerial briefings (Elected Members, the Chief Executive Officer and Executive Management only);
- b. Meetings of clubs or organisations within the Shire of Narrogin;
- c. Any free event held within the Shire of Narrogin;
- d. Australian or West Australian Local Government events;
- e. Events hosted by Clubs or Not for Profit Organisations within the Shire of Narrogin to which the Shire President, Elected Member, Chief Executive Officer or employee has been officially invited;
- f. Shire hosted ceremonies and functions;
- g. Shire hosted events with employees;
- h. Shire run tournaments or events;
- i. Shire sponsored functions or events;
- j. Community art exhibitions within the Shire of Narrogin or District;
- k. Cultural events/festivals within the Shire of Narrogin or District;
- l. Events run by a Local, State or Federal Government;
- m. Events run by schools and universities within the Shire of Narrogin;

- n. Major professional bodies associated with local government at a local, state and federal level;
- o. Opening or launch of an event or facility within the Shire of Narrogin or District;
- p. Recognition of Service event's within the Shire of Narrogin or District;
- q. RSL events within the Shire of Narrogin or District;
- r. Events run by WALGA, LGIS or a recognised and incorporated WA based local government professional association;
- s. ARTS Narrogin events; and
- t. Where Shire President, Elected Member or Chief Executive Officer representation has been formally requested.

2. Approval Process

Where an invitation is received to an event that is not listed as permitted and not prohibited or requiring Council approval, it may be submitted for approval prior to the event for approval as follows:

- Events for the Shire President may be approved by the Deputy Shire President;
- Events for Councillors may be approved by the Shire President;
- Events for the Chief Executive Officer may be approved by the Shire President; and
- Events for employees may be approved by the Chief Executive Officer or their respective Executive Manager.

Considerations for approval of the event include:

- Any justification provided by the applicant when the event is submitted for approval.
- The benefit to the Shire of the person attending.
- Alignment to the Shire's Strategic Objectives.
- The number of Shire representatives already approved to attend.

3. Other Matters

- If the event is a free event to the public then no action is required.
- If the event is ticketed and the Elected Member, Chief Executive Officer or employee pays the full ticketed price and does not seek reimbursement, then no action is required.
- If the event is ticketed and the Elected Member, Chief Executive Officer or employee pays a discounted rate, or is provided with a free ticket(s), with a discount value, then the recipient must disclose receipt of the tickets (and any other associated hospitality) within 10 days to the Chief Executive Officer (or President if the CEO) if the discount or free value is greater than \$50 for employees, other than the Chief Executive Officer, and greater than \$300 for Elected Members and the CEO.

4. Conference Registration, Bookings, Payment and Expenses

Shall be dealt with in accordance with Council Policies and relevant employment contracts:

- 1.8 Elected Members – Conference, Training, Travel and out of pocket Expenses
- 8.13 Training, Study and Education (for employees and the Chief Executive Officer)

6. Dispute Resolution

All disputes regarding the approval of attendance at events are to be resolved by the Shire President in relation to Elected Members and the Chief Executive Officer and the CEO in relation to other employees.

PROCEDURES

Organisations that desire attendance at an event by a particular person(s), such as the President, Deputy President, Elected Member, Chief Executive Officer or particular officer of the Shire, should clearly indicate that on the offer, together what is expected of that individual, should they be available, and whether the invite / offer or ticket is transferable to another Shire representative.

Free or discounted Invitations / Offers or Tickets that are provided to the Shire without denotation as to who they are for, are provided to the Chief Executive Officer and attendance determined by the Chief Executive Officer in liaison with the Shire President, based on relative benefit to the organisation in attending the event, the overall cost in attending the event, inclusive of travel or accommodation, availability of representatives, and the expected role of the relevant Elected Member or employee.

Forms and Templates

[FCEO0016 Declaration of Gifts/Contributions to Travel](#) Form is required to be completed and lodged within 10 days, if the gift of free or discounted attendance is provided in their name due to or as part of their role with the Shire of Narrogin as follows:

- If the gift is provided to the Elected Member and the discount or free value is over \$300, inclusive of GST, with the Chief Executive Officer;
- If the gift is provided to the Chief Executive Officer and the discount or free value is over \$300, inclusive of GST with the Shire President; and
- If the gift is provided to an employee, other than the Chief Executive Officer, and the discount or free value is over \$50, inclusive of GST, with the Chief Executive Officer.

– End of Policy

Notes

Statutory requirement –

The Local Government Act requires that the code may only be adopted or amended by absolute majority.

Deleted: Nil

1.16 Fraud and Corruption Prevention

Statutory context Local Government (Audit) Regulations 1996 –
- r.17 – CEO to review certain systems and procedures

Local Government (Financial Management) Regulations 1996 –
- r.5 – CEO's duties as to financial management

Corporate context Council Policy Manual –
- [1.1 – Code of Conduct](#)
- [8.1 – Disciplinary Action](#)

[Code of Conduct – Employees](#)

Shire of Narrogin Fraud and Corruption Prevention Plan

History Adopted 24 March 2020
[Last reviewed 7 June 2021](#)

Policy Statement

1. All Elected Members and employees have a key responsibility to safeguard against damage and loss through fraud, corruption or misconduct and have an obligation to support efforts to reduce associated risk by behaving with integrity and professionalism in undertaking their duties.
2. The Shire expects its elected members and employees to act in compliance with the Codes of Conduct and behave ethically and honestly when performing their functions and during their interactions with each other, the community and all stakeholders of the Shire.
3. All suspected instances of fraudulent or corrupt conduct are to be thoroughly investigated and the appropriate reporting, disciplinary, prosecution and recovery actions initiated.
4. The Chief Executive Officer is to ensure that a Fraud and Corruption Prevention Plan is developed, reviewed by the Audit Committee, and adopted by Council at least once every two years.

Forms and Templates

Nil

– End of Policy

Notes

1.17 Continuing Professional Development

Statutory context Local Government Act 1995, Sec 5.127 and Sec 5.128

Corporate context

History Adopted 24 March 2020
[Last reviewed 7 June 2021](#)

Objective

To ensure that Elected Members of the Shire of Narrogin receive appropriate information and training to enable them to understand and undertake their responsibilities and obligations.

Policy Statement

The Shire of Narrogin recognises the importance of providing Elected Members with the knowledge and resources that will enable them to fulfil their role in accordance with statutory compliance and community expectations and make educated and informed decisions.

Pursuant to the Local Government Act 1995, Elected Members must complete Council Member Essentials which incorporates the following training units:

- a) Understanding Local Government;
- b) Conflicts of Interest;
- c) Serving on Council;
- d) Meeting Procedures and Debating; and
- e) Understanding Financial Report and Budgets.

Council's preferred provider for the training is WALGA (WA Local Government Association).

All units and associated costs will be paid for by the Shire and must be completed by 30 June in the year immediately following the elected Member's election. The training is valid for a period of five years.

Additionally, the Shire will publish, on the Shire's website, training undertaken by all Elected Members within one month after the end of the financial year pursuant to Local Government Act 1995.

It is Council's preference that the training is undertaken via the eLearning method which is the more cost efficient form of delivery. It is acknowledged however that there may be Elected Members who prefer to receive training face-to-face and/or opportunities to attend training which is being delivered in the region or in the Perth metropolitan area.

Procedures

Considerations for approval of the training or professional development activity include:

- The costs of attendance including registration, travel and accommodation, if required;
- The Budget provisions allowed and the uncommitted or unspent funds remaining;
- Any justification provided by the applicant when the training is submitted for approval;
- The benefits to the Shire of the person attending;
- Identified skills gaps of elected members both individually and has a collective;
- Alignment to the Shire's Strategic Objectives; and
- The number of Shire representatives already approved to attend.

Consideration of attendance at training or professional development courses, other than the online Council Member Essentials, which are deemed to be approved, are to be assessed as follows:

- Events for the Shire President must be approved by the Deputy Shire President, in conjunction with the CEO; and
- Events for Councillors must be approved by either the Council or the Shire President, in conjunction with the CEO.

Note well: any expenditure commitments associated with training or professional development must be performed by and authorised through the CEO.

Forms and Templates

Nil

– End of Policy

Notes

Statutory requirement –

[The Local Government Act requires that the policy may only be adopted or amended by absolute majority.](#)

A copy of this Policy (S 5.128) and the Annual Report of Elected Members training (S 5.127) undertaken for the preceding financial year is available here:

<https://www.narrogin.wa.gov.au/your-shire/your-council/elected-members-training.aspx>

1.18 Standards for CEO Recruitment, Performance and Termination

Statutory context Local Government Act 1995, Section 5.39B;
Local Government (Administration) Amendment Regulations 2021; and
Local Government (Administration) Regulations 1996.

Corporate context

History Adopted 24 February 2021
Last reviewed

Statutory requirement –

The Local Government Act requires that the standards may only be adopted or amended by absolute majority.

-- See over --

Adopted Standards for CEO Recruitment, Performance and Termination



Schedule 2 — Model standards for CEO recruitment, performance and termination [Local Government Act 1995 S5.39A & Local Government (Administration) Regulations 1996 R18FA].

1. Citation

These are the Shire of Narrogin Standards for CEO Recruitment, Performance and Termination.

2. Terms used

(1) In these standards —

Act means the Local Government Act 1995;

additional performance criteria means performance criteria agreed by the local government and the CEO under clause 16(1)(b);

applicant means a person who submits an application to the local government for the position of CEO;

CEO means the local government's Chief Executive Officer;

contract of employment means the written contract, as referred to in section 5.39 of the Act, that governs the employment of the CEO;

contractual performance criteria means the performance criteria specified in the CEO's contract of employment as referred to in section 5.39(3)(b) of the Act;

job description form means the job description form for the position of CEO approved by the local government under clause 5(2);

local government means the [insert name of local government];

selection criteria means the selection criteria for the position of Chief Executive Officer determined by the local government under clause 5(1) and set out in the job description form;

selection panel means the selection panel established by the local government under clause 8 for the employment of a person in the position of CEO.

(2) Other terms used in these standards that are also used in the Act have the same meaning as they have in the Act, unless the contrary intention appears.

Division 2 — Standards for recruitment of CEOs

3. Overview of Division

This Division sets out standards to be observed by the local government in relation to the recruitment of CEOs.

4. Application of Division

(1) Except as provided in subclause (2), this Division applies to any recruitment and selection process carried out by the local government for the employment of a person in the position of CEO.

(2) This Division does not apply —

(a) if it is proposed that the position of CEO be filled by a person in a class prescribed for the purposes of section 5.36(5A) of the Act; or

(b) in relation to a renewal of the CEO's contract of employment, except in the circumstances referred to in clause 13(2).

5. Determination of selection criteria and approval of job description form

(1) The local government must determine the selection criteria for the position of CEO, based on the local government's consideration of the knowledge, experience, qualifications and skills necessary to effectively perform the duties and responsibilities of the position of CEO of the local government.

(2) The local government must, by resolution of an absolute majority of the council, approve a job description form for the position of Chief Executive Officer which sets out —

(a) the duties and responsibilities of the position; and

(b) the selection criteria for the position determined in accordance with subclause (1).

6. Advertising requirements

(1) If the position of CEO is vacant, the local government must ensure it complies with section 5.36(4) of the Act and the Local Government (Administration) Regulations 1996 regulation 18A.

(2) If clause 13 applies, the local government must advertise the position of CEO in the manner referred to in the Local Government (Administration) Regulations 1996 regulation 18A as if the position was vacant.

7. Job description form to be made available by local government

If a person requests the local government to provide to the person a copy of the job description form, the local government must —

(a) inform the person of the website address referred to in the

Local Government (Administration) Regulations 1996 regulation 18A(2)(da); or

(b) if the person advises the local government that the person is unable to access that website address —

(i) email a copy of the job description form to an email address provided by the person; or

(ii) mail a copy of the job description form to a postal address provided by the person.

8. Establishment of selection panel for employment of CEO

(1) In this clause —

independent person means a person other than any of the following —

(a) a council member;

(b) an employee of the local government;

(c) a human resources consultant engaged by the local government.

(2) The local government must establish a selection panel to conduct the recruitment and selection process for the employment of a person in the position of CEO.

(3) The selection panel must comprise —

(a) council members (the number of which must be determined by the local government); and

(b) at least 1 independent person.

9. Recommendation by selection panel

(1) Each applicant's knowledge, experience, qualifications and skills must be assessed against the selection criteria by or on behalf of the selection panel.

(2) Following the assessment referred to in subclause (1), the selection panel must provide to the local government —

(a) a summary of the selection panel's assessment of each applicant; and

(b) unless subclause (3) applies, the selection panel's recommendation as to which applicant or applicants are suitable to be employed in the position of CEO.

(3) If the selection panel considers that none of the applicants are suitable to be employed in the position of CEO, the selection panel must recommend to the local government —

(a) that a new recruitment and selection process for the position be carried out in accordance with these standards; and

(b) the changes (if any) that the selection panel considers should be made to the duties and responsibilities of the position or the selection criteria.

(4) The selection panel must act under subclauses (1), (2) and (3) —

(a) in an impartial and transparent manner; and

(b) in accordance with the principles set out in section 5.40 of the Act.

(5) The selection panel must not recommend an applicant to the local government under subclause (2)(b) unless the selection panel has —

(a) assessed the applicant as having demonstrated that the applicant's knowledge, experience, qualifications and skills meet the selection criteria; and

(b) verified any academic, or other tertiary level, qualifications the applicant claims to hold; and

(c) whether by contacting referees provided by the applicant or making any other inquiries the selection panel considers appropriate, verified the applicant's character, work history, skills, performance and any other claims made by the applicant.

(6) The local government must have regard to, but is not bound to accept, a recommendation made by the selection panel under this clause.

10. Application of cl. 5 where new process carried out

(1) This clause applies if the local government accepts a recommendation by the selection panel under clause 9(3)(a) that a new recruitment and selection process for the position of CEO be carried out in accordance with these standards.

(2) Unless the local government considers that changes should be made to the duties and responsibilities of the position or the selection criteria —

(a) clause 5 does not apply to the new recruitment and selection process; and

(b) the job description form previously approved by the local government under clause 5(2) is the job description form for the purposes of the new recruitment and selection process.

11. Offer of employment in position of CEO

Before making an applicant an offer of employment in the position of CEO, the local government must, by resolution of an absolute majority of the council, approve —

(a) the making of the offer of employment to the applicant; and

(b) the proposed terms of the contract of employment to be entered into by the local government and the applicant.

12. Variations to proposed terms of contract of employment

(1) This clause applies if an applicant who is made an offer of employment in the position of CEO under clause 11 negotiates with the local government a contract of employment (the negotiated contract) containing terms different to the proposed terms approved by the local government under clause 11(b).

(2) Before entering into the negotiated contract with the applicant, the local government must, by resolution of an absolute majority of the council, approve the terms of the negotiated contract.

13. Recruitment to be undertaken on expiry of certain CEO contracts

(1) In this clause —

commencement day means the day on which the Local Government (Administration) Amendment Regulations 2021 regulation 6 comes into operation.

(2) This clause applies if —

(a) upon the expiry of the contract of employment of the person (the incumbent CEO) who holds the position of CEO —

(i) the incumbent CEO will have held the position for a period of 10 or more consecutive years, whether that period commenced before, on or after commencement day; and
(ii) a period of 10 or more consecutive years has elapsed since a recruitment and selection process for the position was carried out, whether that process was carried out before, on or after commencement day; and
(b) the incumbent CEO has notified the local government that they wish to have their contract of employment renewed upon its expiry.

(3) Before the expiry of the incumbent CEO's contract of employment, the local government must carry out a recruitment and selection process in accordance with these standards to select a person to be employed in the position of CEO after the expiry of the incumbent CEO's contract of employment.

(4) This clause does not prevent the incumbent CEO's contract of employment from being renewed upon its expiry if the incumbent CEO is selected in the recruitment and selection process referred to in subclause (3) to be employed in the position of CEO.

14. Confidentiality of information

The local government must ensure that information provided to, or obtained by, the local government in the course of a recruitment and selection process for the position of CEO is not disclosed, or made use of, except for the purpose of, or in connection with, that recruitment and selection process.

Division 3 — Standards for review of performance of CEOs

15. Overview of Division

This Division sets out standards to be observed by the local government in relation to the review of the performance of CEOs.

16. Performance review process to be agreed between local government and CEO

(1) The local government and the CEO must agree on —
(a) the process by which the CEO's performance will be reviewed; and
(b) any performance criteria to be met by the CEO that are in addition to the contractual performance criteria.
(2) Without limiting subclause (1), the process agreed under subclause (1)(a) must be consistent with clauses 17, 18 and 19.
(3) The matters referred to in subclause (1) must be set out in a written document.

17. Carrying out a performance review

(1) A review of the performance of the CEO by the local government must be carried out in an impartial and transparent manner.
(2) The local government must —

(a) collect evidence regarding the CEO's performance in respect of the contractual performance criteria and any additional performance criteria in a thorough and comprehensive manner; and

(b) review the CEO's performance against the contractual performance criteria and any additional performance criteria, based on that evidence.

18. Endorsement of performance review by local government

Following a review of the performance of the CEO, the local government must, by resolution of an absolute majority of the council, endorse the review.

19. CEO to be notified of results of performance review

After the local government has endorsed a review of the performance of the CEO under clause 18, the local government must inform the CEO in writing of —

(a) the results of the review; and
(b) if the review identifies any issues about the performance of the CEO — how the local government proposes to address and manage those issues.

Division 4 — Standards for termination of employment of CEOs

20. Overview of Division

This Division sets out standards to be observed by the local government in relation to the termination of the employment of CEOs.

21. General principles applying to any termination

(1) The local government must make decisions relating to the termination of the employment of a CEO in an impartial and transparent manner.
(2) The local government must accord a CEO procedural fairness in relation to the process for the termination of the CEO's employment, including —
(a) informing the CEO of the CEO's rights, entitlements and responsibilities in relation to the termination process; and
(b) notifying the CEO of any allegations against the CEO; and
(c) giving the CEO a reasonable opportunity to respond to the allegations; and
(d) genuinely considering any response given by the CEO in response to the allegations.

22. Additional principles applying to termination for performance-related reasons

(1) This clause applies if the local government proposes to terminate the employment of a CEO for reasons related to the CEO's performance.
(2) The local government must not terminate the CEO's employment unless the local government has —
(a) in the course of carrying out the review of the CEO's performance referred to in subclause (3) or any other review of the CEO's performance, identified any issues (the performance issues) related to the performance of the CEO; and
(b) informed the CEO of the performance issues; and

(c) given the CEO a reasonable opportunity to address, and implement a plan to remedy, the performance issues; and

(d) determined that the CEO has not remedied the performance issues to the satisfaction of the local government.

(3) The local government must not terminate the CEO's employment unless the local government has, within the preceding 12-month period, reviewed the performance of the CEO under section 5.38(1) of the Act.

23. Decision to terminate

Any decision by the local government to terminate the employment of a CEO must be made by resolution of an absolute majority of the council.

24. Notice of termination of employment

(1) If the local government terminates the employment of a CEO, the local government must give the CEO notice in writing of the termination.

(2) The notice must set out the local government's reasons for terminating the employment of the CEO.

- End of Schedule

A copy of these Standards is to be placed on the local government's official website, pursuant to Section 5.39B(6) of the Local Government Act 1995.

Section 2 - ADMINISTRATION / ORGANISATION

2.1 Senior Employees – Designation & Appointing Acting CEO

Statutory context Local Government Act 1995 –

- s.5.37 – senior employee or class of employee may be designated
- Local Government Act 1995, Section 5.39C and 5.36 (2); and
- Local Government (Administration) Amendment Regulations 2021.

Corporate context Delegation 1.2 – Acting CEO (Appointment)

History

Adopted	26 April 2017
Last reviewed	24 July 2019
Amended	24 February 2021
Last reviewed	7 June 2021

Policy Statement

Pursuant to Section 5.37 of the Local Government Act 1995, the following employees are designated as senior employees –

- a) Executive Manager, Corporate and Community Service;
- b) Executive Manager, Development and Regulatory Services; and
- c) Executive Manager, Technical and Rural Services.

For the purposes of Section 5.36 (2) of the Local Government Act 1995, the Council has determined that employees that are appointed in one of the above positions are suitably qualified to be appointed as Acting CEO by the CEO, from time to time, when the CEO is on periods of leave, subject to the following condition:

1. The CEO is not an interim CEO or Acting in the position;
2. The term of appointment is not longer than 20 working days consecutive;
3. That the employee's employment conditions are not varied other than the employee is entitled at the CEO's discretion, no greater than the salary equivalent to that of the CEO during the Acting period.

In the case of the unavailability of the CEO due to an emergency, the Executive Manager Corporate & Community Services is automatically appointed as the Acting CEO for up to 2 weeks from commencement, and continuation is then subject to determination by the Council.

All other interim, Acting or CEO appointments to be referred to Council".

– End of Policy

Notes

Statutory requirement –

[The Local Government Act requires that matters relating to the appointment of a temporary or acting CEO may only be adopted or amended by absolute majority.](#)

CEO is a designated senior employee under the Act. There is no requirement to have designated employees other than for the purpose of automatic appointment as Acting Chief Executive Officer. Most requirements placed on designated employees are already covered by s.5.74 – to declare gifts and to make primary / annual declarations if making direct report to Council or exercising delegated authority.

2.2 Acting / Relieving Staff Authority

Statutory context	Local Government Act 1995
Corporate context	Delegation 1.2 – Acting CEO – Appointment Policy 8.5 – Higher Duties Executive Instructions – - 8.5 – Higher Duties
History	Adopted 26 April 2017 Last reviewed 24 July 2019 Last reviewed 7 June 2021

Policy Statement

1. To ensure that acting and relieving staff have clear authority to fulfil the requirements of the position, a person acting or relieving in a position, however temporarily and of whatever duration, is authorised to exercise all duties, powers and responsibilities assigned to that position, whether a delegation, policy, direction or accepted practice, subject only to any limitations that may be imposed by the CEO.
2. Acting or relieving staff are to be aware that their tenure is temporary, and to take into account when making decisions, the likely views and preferences of the permanent appointee.

– End of Policy

Notes

[Refer Policy 2.1 for matters relating to temporary or acting CEO.](#)

Deleted: ¶
Notes –¶
Appointment as Acting CEO is subject to either –¶
specific decision of Council as per the Local Government Act,
or ¶
Delegation 1.2 Acting CEO – Appointment.¶

2.3 Display of National and Other Flags

Statutory context Flags Act 1953 (Commonwealth)

Corporate context None

History Adopted 26 April 2017
Last reviewed 24 July 2019
[Last reviewed 7 June 2021](#)

Policy Statement

1. The Shire recognises the significance of certain flags connected to its governance responsibilities and will utilise Council flagpoles to fly such flags.
2. The flags that are to be flown each working day are the –
 - a) Australian National flag,
 - b) Australian Aboriginal flag, and
 - c) Shire of Narrogin flag.
3. The Western Australian State flag and any other flag/s approved by Council or CEO may be flown on appropriate occasions.
4. Flags flown in response to Council's governance responsibilities will be flown in accordance with the relevant legislation and protocols in force at the time.
5. Order of precedence of flags –
 - (1) Australian National flag,
 - (2) National flags of other nations;
 - (3) State and Territory flags,
 - (4) Other flags prescribed by the Flags Act 1953 (Commonwealth)–
 - (a) Australian Aboriginal flag and the Torres Strait Islander flag in either order
 - (b) Australian Defence Force Ensign
 - (c) Australian White Ensign
 - (d) Royal Australian Air Force Ensign,
 - (5) Ensigns and pennants –
 - (a) Local Government,
 - (b) Commonwealth, State and Territory agencies,
 - (c) Non-Government organisations,
 - (6) Banners:
6. Flags should not be flown with any other flag on the same flagpole

– End of Policy

Notes

Refer – Department of the Prime Minister and Cabinet

<https://www.dpmc.gov.au/government/australian-national-flag/australian-national-flag-protocols>

<https://www.dpmc.gov.au/resource-centre/government/australian-flags-booklet-part-two>

(5 January 2017)

2.4 Amendments to Council Policy

Statutory context

[Local Government Act – 2.7\(2\)\(b\) – a role of Council is to determine the local government's policies.](#)

Deleted: None

Corporate context None

History

Adopted	26 April 2017
Last reviewed	24 July 2019
Last reviewed	7 June 2021

Policy Statement

1. The CEO is to maintain the official copy of the Council Policy Manual, updated as soon as possible after each authorised resolution of Council.
2. Additions, deletions or alterations to Council Policy Statements shall only be made by specific Council resolution stating –
 - a) stating the current Council Policy number if an amendment or deletion,
 - b) the proposed policy number to clearly indicate functional area if a new Council Policy, and
 - c) proposed wording and justification for the amendment, deletion or adoption.

– End of Policy

Notes

The purpose of policy documents is to enable the effective and efficient management of Council resources and to assist staff and Council achieve an equitable decision making process. Written policies also enable the community to be aware of the reasoning behind administrative and Council decisions, and to be familiar with the philosophy behind individual decisions.

If it is not in the Council Policy Manual, it may be usual practice, but it is not Council Policy. Unless it is specifically stated that the authority is to be included in the Policy Manual, it is to be considered that the authority to act, is for a specific matter and is not general or on-going.

2.5 Information & Communications Technology Usage

WALGA Workplace Relations, November 2016 – amended

Statutory context Local Government Act 1995

Corporate context

Policy 2.6 – Social Media Use
Policy 8.1 – Disciplinary Action

[Code of Conduct – Employees](#)

Executive Instructions –

- 2.1 – Information & Communications Technology Usage
- 2.2 – Social Media

History

Adopted	26 April 2017
Last reviewed	24 July 2019
Last reviewed	7 June 2021

Deleted: Policy 1.1 – Code of Conduct

Policy Statement

1. The CEO is to prepare and maintain a detailed Executive Instruction regarding this matter, which is to include but is not limited to –
 - a) employees, consultants or contractors entitled to have access to ICT,
 - b) general use of ICT resources,
 - c) unacceptable use,
 - d) security and proprietary information,
 - e) system and network activities,
 - f) email activities,
 - g) remote access,
 - h) provision of mobile phones and information/communication devices,
 - i) Department of Transport licencing,
 - j) consequences of breach of the Executive Instructions.

– End of Policy

Notes

2.6 Social Media

WALGA Workplace Relations, November 2016 – amended

Statutory context Local Government Act 1995

Corporate context ▼

Policy 2.5 – Information and Communications Technology Usage
Policy 8.1 – Disciplinary Action
Policy 8.2 – Discrimination, Bullying and Harassment

[Code of Conduct – Employees](#)

Executive Instructions –

- 2.1 – Information & Communications Technology Usage
- 2.2 – Social Media

History
Adopted 26 April 2017
Last reviewed 24 July 2019
[Last reviewed 7 June 2021](#)

Policy Statement

1. The CEO is to prepare and maintain a detailed Executive Instruction regarding this matter, which is to include but is not limited to –
 - a) application to all employees, volunteers and contractors,
 - b) use of social media for Shire purposes to be specifically authorised by CEO, or by persons authorised by CEO,
 - c) limitations on private use of Shire corporate sites,
 - d) use of any site to comment on Shire related matters, in particular if such comment is considered to be bullying, harassing or derogatory in nature, or which damages the Shire reputation, will make the employee liable to disciplinary action,
 - e) consequences of breach of the Executive Instruction.

– End of Policy

Notes

Deleted: Policy 1.1 – Code of Conduct

2.7 Shire Logo

Statutory context	Copyright Intellectual property
Corporate context	Shire of Narrogin Corporate Style Guide
History	Adopted 26 April 2017 Last reviewed 24 July 2019 Last reviewed 7 June 2021

Policy Statement

1. The CEO is to prepare and maintain a Style Guide regarding this matter, which is to include but is not limited to –
 - a) use of adopted logo, colours, fonts etc
 - b) formatting etc
2. The primary logo of the Shire is –
3. The logo should be used –
 - a) on all Shire publications, letterheads, promotional materials etc
 - b) where the Shire has provided sponsorship or support for a program, activity or advertisement – e.g. Homecare program, sporting or community event.
4. Private use of the logo is not permitted unless –
 - a) the approval of the CEO has been obtained, and
 - b) there is an identifiable benefit to the Shire or community through acknowledgement of support or promotion of the area.
5. Approval for private use of the logo may be withdrawn at any if the use is considered to be inappropriate.
6. Permitted variations to the logo are –
 - a) use of separate panels within an overall design/program,
 - b) text in an alternative position,
 - c) tag line colour may vary in order to be more visible,
 - d) tag line may be swapped out for a facility, department or section name, e.g. RW (Bob) Farr Memorial Library, Narrogin Homecare etc
 - e) to be approved by CEO before use.



– End of Policy

Notes

2.8 Enterprise Risk Management

Statutory context	Occupational Safety and Health Act 1984
	Local Government (Audit) Regulations 1996
	- reg.17 – CEO to review risk management and report to Audit Committee
Corporate context	Council Committees and Reference Groups, Establishment and Terms of Reference – Audit Committee
History	Adopted 26 April 2017
	Amended 24 July 2019
	Last reviewed 7 June 2021

Policy Statement

1. Purpose
The Shire of Narrogin (“the Shire”) Risk Management Policy documents the commitment and objectives regarding managing uncertainty that may impact the Shire’s strategies, goals or objectives.
2. Policy Schedules adopted
The following Council Policy Schedules are adopted, and forms part of this Statement –
2.8 – Risk Appetite
3. Policy
 - a) It is the Shire’s Policy to achieve best practice (aligned with AS/NZS ISO 31000:2018 Risk management), in the management of all risks that may affect the Shire, its customers, people, assets, functions, objectives, operations or members of the public.
 - b) Risk Management will form part of the Strategic, Operational, Project and Line Management responsibilities and where possible, be incorporated within the Shire’s Integrated Planning Framework.
 - c) The Shire’s Executive Management Team will determine and communicate the Risk Management Policy, Objectives and Procedures, as well as direct and monitor implementation, practice and performance.
 - d) Every employee, elected member, volunteer and contractor within the Shire is recognised as having a role in risk management.
 - e) Consultants may be retained at times to advise and assist in the risk management process or management of specific risks or categories of risk.
4. Definitions:
Risk means the effect of uncertainty on objectives.
Note 1: An effect is a deviation from the expected – positive or negative.
Note 2: Objectives can have different aspects (such as financial, health and safety and environmental goals) and can apply at different levels (such as strategic, organisation-wide, project, product or process).
Definition (from AS/NZS ISO 31000:2018)
Risk Management means coordinated activities to direct and control an organisation with regard to risk.
Risk Management Process means the systematic application of management policies, procedures and practices to the activities of communicating, consulting, establishing the context, and identifying, analysing, evaluating, treating, monitoring and reviewing risk.
Risk Management Framework means the set of components that provide the foundations and organisational arrangements for designing, implementing, monitoring, reviewing and continually improving risk management throughout the organisation.
5. Risk Management Objectives
The adoption of consistent risk management processes within a comprehensive framework will help deliver on the objectives and benefits below:
 - Optimise the achievement of our vision, experiences, strategies, goals and objectives.

- Provide transparent and formal oversight of the risk and control environment to enable effective decision making.
 - Enhance risk versus return within our risk appetite.
 - Embed appropriate and effective controls to mitigate risk.
 - Achieve effective corporate governance and adherence to relevant statutory, regulatory and compliance obligations.
 - Enhance organisational resilience.
 - Identify and provide for the continuity of critical operations.
6. Risk Appetite
- a) The Shire has defined its tolerance to risk, its risk appetite, through the development and endorsement of the Shire's Risk Assessment and Acceptance Criteria. The criteria are included within the Risk Management Procedures and are subject to ongoing review in conjunction with this policy.
 - b) All organisational risks to be reported at a corporate level are to be assessed according to the Shire's Risk Assessment and Acceptance Criteria to allow consistency and informed decision making. For operational requirements such as projects or to satisfy external stakeholder requirements, alternative risk assessment criteria may be utilised, however these cannot exceed the organisation's appetite and are to be noted within the individual risk assessment and approved by a member of the Executive Management Team.
7. Roles, Responsibilities & Accountabilities
- a) Council's role is to –
 - review and approve the Shire's Risk Management Policy and Risk Assessment & Acceptance Criteria,
 - determine the organisation's appetite for risk,
 - establish and maintain an Audit Committee in terms of the Local Government Act.
 - b) The CEO is responsible for the allocation of roles, responsibilities and accountabilities, which are documented in the Risk Management Procedures (Operational Document).
8. Monitor & Review
- a) The Shire will implement and integrate a monitor and review process to report on the achievement of the Risk Management Objectives, the management of individual risks and the ongoing identification of issues and trends.
 - b) This policy will be kept under review by the Shire's Executive Management Team and will be formally reviewed by Council biennially.

– End of Policy

Notes

Policy Schedule 2.8 – Risk Appetite

MEASURES OF CONSEQUENCE

RATING	PEOPLE	INTERRUPTION TO SERVICE	REPUTATION (Social / Community)	COMPLIANCE	PROPERTY (Plant, Equipment, Buildings)	NATURAL ENVIRONMENT	FINANCIAL IMPACT	PROJECT	
								TIME	COST
Insignificant (1)	No injuries or illness	No material service interruption Less than 1 hour	Unsubstantiated, localised low impact on community trust, low profile or no media item.	No noticeable regulatory or statutory impact	Inconsequential damage.	Contained, reversible impact managed by on site response	Less than \$1,000	Exceeds deadline by 5% of project timeline	Exceeds project budget by 5%
Minor (2)	First Aid Treatment	Short term temporary interruption – backlog cleared < 1 day	Substantiated, localised impact on community trust or low media item	Some temporary non compliances	Localised damage rectified by routine internal procedures	Contained, reversible impact managed by internal response	\$10,001 - \$25,000	Exceeds deadline by 10% of project timeline	Exceeds project budget by 15%
Moderate (3)	Medical treatment / Lost time injury >10 Days	Medium term temporary interruption – backlog cleared by additional resources < 1 week	Substantiated, public embarrassment, moderate impact on community trust or moderate media profile	Short term non-compliance but with significant regulatory requirements imposed	Localised damage requiring external resources to rectify	Contained, reversible impact managed by external agencies	\$25,001 - \$100,000	Exceeds deadline by 15% of project timeline	Exceeds project budget by 25%
Major (4)	Lost time injury >30 Days / temporary disability	Prolonged interruption of services – additional resources; performance affected < 1 month	Substantiated, public embarrassment, widespread high impact on community trust, high media profile, third party actions	Non-compliance results in termination of services or imposed penalties to Shire/Officers	Significant damage requiring internal & external resources to rectify	Uncontained, reversible impact managed by a coordinated response from external agencies	\$100,001 – \$500,000	Exceeds deadline by 20% of project timeline	Exceeds project budget by 35%
Extreme (5)	Fatality, permanent disability	Indeterminate prolonged interruption of services non- performance > 1 month	Substantiated, public embarrassment, widespread loss of community trust, high widespread multiple media profile, third party actions	Non-compliance results in litigation, criminal charges or significant damages or penalties to Shire/Officers	Extensive damage requiring prolonged period of restitution. Complete loss of plant, equipment & building	Uncontained, irreversible impact	More than \$500,000	Exceeds deadline by 25% of project timeline	Exceeds project budget by 45%

MEASURES OF LIKELIHOOD

Level	Rating	Description	Frequency
5	Almost Certain	The event is expected to occur in most circumstances	More than once per year
4	Likely	The event will probably occur in most circumstances	At least once per year
3	Possible	The event should occur at some time	At least once in 3 years
2	Unlikely	The event could occur at some time	At least once in 10 years
1	Rare	The event may only occur in exceptional circumstances	Less than once in 15 years

RISK MATRIX

Consequence		Insignificant	Minor	Moderate	Major	Extreme
Likelihood		1	2	3	4	5
Almost Certain	5	Moderate (5)	High (10)	High (15)	Extreme (20)	Extreme (25)
Likely	4	Low (4)	Moderate (8)	High (12)	High (16)	Extreme (20)
Possible	3	Low (3)	Moderate (6)	Moderate (9)	High (12)	High (15)
Unlikely	2	Low (2)	Low (4)	Moderate (6)	Moderate (8)	High (10)
Rare	1	Low (1)	Low (2)	Low (3)	Low (4)	Moderate (5)

– End of Schedule

2.9 Annual Closure During Christmas Period

Statutory context	Nil
Corporate context	8.6 Leave – Award Entitlements.
History	Adopted 27 November 2019 Last reviewed 7 June 2021

Policy Statement

That the Administration Office, Works Depot, RW (Bob) Farr Memorial Library and Jessie House/Homecare Office operating dates during the Christmas period be closed at the end of normal business hours on Christmas Eve and reopen the day following New Year's Day, subject to the Chief Executive Officer ensuring that an emergency contact list is maintained for senior officers and key personnel and the closures being widely advertised prior.

Procedures

Advertising

At the beginning of December each year, an advertising plan be coordinated by the CEO's Office to widely advertise the closure periods for:

- Administration Office
- Works Depot
- RW (Bob) Farr Memorial Library
- Jessie House/Homecare.

Consider in the advertising plan, the closure dates of the Waste Management Facility and if there are alterations to kerbside rubbish collections during the Christmas/New Year period.

Processing of Leave

Staff are to apply for their required amount of leave utilising any accrued RDOs first and then any accrued Annual Leave. Employees with insufficient paid leave will be expected to take time off without pay.

Forms and Templates

FCEO001 Advertising Communications Plan Form

FCCS001 Application for Leave Form

– End of Policy

Notes

Section 3 - FINANCIAL MANAGEMENT

3.1 Purchasing

- Statutory context** Local Government (Functions and General) Regulations 1996 –
- r.11A – purchasing policy required, and matters to be addressed
- Corporate context** Delegation 3.1 – Tenders – power to set specifications, criteria, call, accept, vary
- Policy Manual –
- Policy 3.8 – Transaction Cards

[Code of Conduct – Employees](#)

- Executive Instructions –
- 3.1 – Purchasing – Documentation
- 3.3 – Credit (Transaction) cards

History

Adopted	26 April 2017
Amended	24 July 2019
Amended	26 May 2020
Amended	23 June 2021

Policy Statement

1. The following Council Policy Schedules are adopted, and form part of this Statement –
 - 3.1(a) – Purchasing Principles
 - 3.1(b) – Purchasing Thresholds
 - 3.1(c) – Regulatory Compliance
2. Where the goods or services are to be accessed from the WA Local Government Association Preferred Supplier Panel or State Government Common Use Agreement, compliance with Policy Schedule 3.1(b) Purchasing Thresholds, clause 1 is required.
3. Proposals for consultancies, works and services etc, to be provided on Shire managed sites are also to be assessed in accordance with –
 - Policy 9.1 OSH – Employees, Volunteers, Contractor and Visitors.
 - Executive Instructions issued by the CEO
 - OSH Contractor Handbook or associated documents.
4. A quotation is to be obtained and a purchase order is required to be issued, except for –
 - reimbursement of expenses incurred by a councillor or employee on approved Shire business, where receipts are provided or a statutory declaration is made
 - o eg: parking fees, taxi fares etc
 - non-contracted or non-contestable utilities (e.g. electricity, water, telephone),
 - regular or statutory expenses of a periodic nature (e.g. rates & taxes, insurance, licenses, superannuation, etc),
 - employee/elected member allowances.
 - other payments as determined by the CEO in Executive Instruction.

Examples include –

- YMCA WA for payments for employee memberships per Council Policy
 - Credit Card purchases below \$1,500
 - All freight companies for delivery fees
 - Petty cash purchases
 - Store card purchases
 - Fuel card purchases
 - Regional Risk Coordinator Scheme by Local Government Insurance Services
 - Security and on-going alarm monitoring services.
5. A procurement is exempt from the need to obtain quotations and issue of a purchase order where a standing account has been established, as determined by the CEO in Executive Instruction.
6. Insufficient quotations received
Where the required number of quotations have been sought from suppliers capable of meeting the requirements, but an insufficient number of quotations have been received, a quote may nevertheless be accepted if satisfied with all other aspects of the proposed purchase –
- a) where the purchase is \$15,000 or more – by the CEO.
 - b) where the purchase is less than \$15,000 ex GST – by the CEO or relevant Executive Manager.
7. Exceptional Circumstances
- a) Under exceptional circumstances, where goods or services need to be purchased urgently and there is insufficient time to obtain quotations, the CEO may permit the required purchase, notwithstanding the thresholds and requirements of Schedule 3.1(b), subject to the purchase being less than \$250,000 ex GST. Unique value for money circumstances that preclude obtaining quotes must exist, such as –
 - it is opportunistic such as eliminating otherwise applicable costs, in the opinion of the CEO,
 - it enhances operational efficiency,
 - mitigates against risk etc. or
 - it is appropriate in the opinion of the CEO for continuity of previous works, services, or design.
 - b) Procurement under exceptional circumstances must be approved in advance by the CEO.
 - c) Schedule 3.1(b) Purchasing Thresholds and Requirements is suspended during a state of emergency declared in accordance with Emergency Management Act 2005, subject to –
 - (i) purchases are to be for goods or services required for the purposes of addressing a need arising from the hazard, or from the impact or consequences of the hazard, to which the state of emergency relates,
 - (ii) purchases of \$50,000 or over are to be approved by the CEO,
 - (iii) purchases of \$7,500 to less than \$50,000 are to be approved by the CEO or relevant Executive Manager.
8. Purchase of road making materials (fill, rock, gravel, water etc) from a landowner is exempt from the requirement to obtain quotes.
9. Any variations or extensions of contracts awarded are to be dealt with in accordance with Delegation 3.2 Contracts – Variations.
10. This Policy applies to all purchasing and procurement activity, and is not limited to tendering.

– End of Policy

Notes

Approved purchasing limits assigned to employees are determined by the CEO.

Clause 7(c) is consistent with the Local Government (Functions and General) Regulations 1996 r.11(1A) and (3)(b)

Policy Schedule 3.1(a) – Purchasing Principles

The object of the Purchasing Framework is to –

- obtain quality goods and services that are judged to deliver the best value-for-money or be the most advantageous,
- provide compliance with the Local Government Act, 1995 and the Functions and General Regulations,
- deliver a best practice approach and procedures to internal purchasing for the Shire,
- ensure consistency for all purchasing activities that integrates within all the Shire operational areas.

1. Ethics & Integrity

All officers and employees of the Shire shall observe the highest standards of ethics and integrity in undertaking purchasing activity and act in an honest and professional manner that supports the standing of the Shire.

The following principles, standards and behaviours must be observed and enforced through all stages of the purchasing process to ensure fair and equitable treatment of all parties –

- full accountability shall be taken for all purchasing decisions and the efficient, effective and proper expenditure of public monies based on achieving value for money,
- all purchasing practices shall comply with relevant legislation, regulations, and requirements consistent with the Shire policies and [Code of Conduct for Employees](#),
- purchasing is to be on a competitive basis in which all suppliers are treated impartially, honestly and consistently,
- all processes, evaluations and decisions shall be transparent, free from bias and fully documented in accordance with applicable policies and audit requirements,
- any actual or perceived conflicts of interest are to be identified, disclosed and appropriately managed,
- any information provided to the Shire by a supplier shall be treated as commercial-in-confidence until such time as the purchase decision is made, and is not be released unless authorised by the supplier or relevant legislation, and
- consideration must be given to any Local Price Preference Policy adopted by Council.

Deleted: code of conduct

2. Value for Money

Value for money is an overarching principle recognised by the Regulations, that allows the best possible outcome to be achieved for the Shire. Compliance with the specification is more important than obtaining the lowest price, particularly taking into account user requirements, quality standards, sustainability, life cycle costing, and service benchmarks.

What constitutes “value for money” or “most advantageous” considerations are to be itemised and detailed as part of evaluation.

An evaluation of the best value for money outcome for any purchasing should consider –

- all relevant whole-of-life costs and benefits (for goods) and whole of contract life costs (for services) including transaction costs associated with acquisition, delivery, distribution, as well as other costs such as but not limited to holding costs, consumables, deployment, maintenance and disposal,
- the technical merits of the goods or services being offered in terms of compliance with specifications, contractual terms and conditions and any relevant methods of assuring quality,
- financial viability and capacity to supply without risk of default. (Competency of the prospective suppliers in terms of managerial and technical capabilities and compliance history),
- a strong element of competition in the allocation of orders or the awarding of contracts. This is achieved by obtaining a sufficient number of competitive quotations wherever practicable,
- continuity of supply or service, and particularly timeliness of any warranty service, emergency or maintenance/repair response, familiarity with works/conditions etc
- where a new or start up business makes a submission, the anticipated longevity of the business, its relevance to the region and if goods or service previously not available in the region.

Where a higher priced conforming offer is recommended, there should be clear benefits over lower priced conforming offers.

3. Sustainable Procurement

Sustainable procurement is defined as the procurement of goods and services that have less environmental and social impacts than competing products and services, and considerations must be balanced against value for money outcomes.

– End of Schedule

Policy Schedule 3.1(b) – Purchasing Thresholds and Requirements

1. Purchasing Thresholds

The value of a purchase is not limited to the financial year when the purchase was initiated, but may be over several financial years depending on the procurement or type of contract.

Records – where required or obtained, the following are to be attached to the purchase order –

- a) Note of verbal specification and submission
- b) Specification required, assessment criteria set, summary of submissions, evaluation made

General purchasing thresholds –

Exemption from requirement to obtain quotations and issue a purchase order is contained in clause 4 and 5 of the Policy Statement.

Anticipated Value of Purchase Excl. GST	Requirement	Documentation
Less than \$2,000	Quotations not required for items of minor recurrent nature, such as groceries, stationery, hardware, mechanical, reticulation consumables etc Employee must be satisfied that the price is competitive	None
\$2,000 to less than \$7,500	Seek at least two verbal quotations Written quotations recommended but not required	Required – - Note of quotations sought - Note of verbal quotations received Recommended – - Written quotations received
\$7,500 to less than \$15,000	Seek at least two written quotations	Required – - Notes of quotations sought - Written quotations
\$15,000 to less than \$50,000	Seek at least three written quotations	Required – - Notes of quotations sought - Written quotations received Recommended – - Written specifications - Assessment criteria - Evaluation panel
\$50,000 to less than \$250,000	Seek at least three written quotations containing price and specification of goods and services	Required – - Notes of quotations sought - Written specification - Written assessment criteria - Written quotations received - Evaluation panel
\$250,000 and above	Conduct a public tender process or WALGA Preferred Supplier / State Government Common Use Agreement Refer to Council for decision unless prior delegation to CEO	Required – - Written specification - Written assessment criteria - Written quotations received - Evaluation panel

WALGA Preferred Supplier or State Government Common Use Agreement thresholds –

Less than \$250,000	As per General threshold	As per General Thresholds
\$250,000 and above	Seek at least three written quotations containing price and specification of goods and services. Refer to Council for decision unless prior delegation to CEO	Required – <ul style="list-style-type: none"> - Notes of quotations sought - Written specification - Written assessment criteria - Written quotations received - Evaluation panel

Notes –

1. Any work done under warranty / guarantee is not considered to be a purchasing activity, but is a part of the original contract / agreement to purchase. Any purchase order issued for warranty / guarantee work is to note this on the purchase order.
2. Any work done outside of warranty / guarantee, even if it may affect warrant / guarantee, is a purchasing activity. Management of that risk is an administrative task, and may be a factor in a “value for money” consideration.

Where it is considered beneficial, tenders may be called in lieu of seeking quotations for purchases under the \$250,000 threshold (excluding GST). If a decision is made to seek public tenders for contracts of less than \$250,000, a Request for Tender process that entails all the procedures for tendering outlined in this policy must be followed in full.

WALGA Preferred Supplier or State Government Common Use Agreement

Policy 3.1 Purchasing Framework adopted by Council stipulates –

Where the goods or services are to be accessed from the WA Local Government Association Preferred Supplier Panel or State Government Common Use Agreement, compliance with Policy Schedule 3.1(b) Purchasing Thresholds, clause 1 is required.

2. Quotations / Submissions

The general principles relating to written quotations / submission are –

- An appropriately detailed specification should communicate requirement(s) in a clear, concise and logical fashion.
- The request for written quotation should include as a minimum:
 - o written specification
 - o assessment criteria to be applied
 - o price schedule
 - o conditions of responding
 - o validity period of offer
- Invitations to quote should be issued simultaneously to ensure that all parties receive an equal opportunity to respond.
- Offer to all prospective suppliers at the same time any new information that is likely to change the requirements.
- Responses should be assessed for compliance, then against the selection criteria, and then value for money and all evaluations documented.
- Respondents should be advised in writing as soon as possible after the final determination is made and approved.

The Local Government Purchasing and Tender Guide produced by the Western Australian Local Government Association (WALGA) should be consulted for further details and guidance.

If it is not possible to get written quotations, a supplier’s verbal “decline to quote” will be sufficient, and is required to be noted with details of date, and name of person who declined.

3. Specifications, Assessment Criteria and Evaluation

Applies to all procurements as determined by the thresholds in clause 1 –

- a) Where a specification is provided or required by clause 1 – What is required to be in the specification may include –
 - Details, format and request to be appropriate to the procurement
 - How many / how much,
 - what size / power etc,
 - how fitted out,

- standard / quality required,
 - type of construction,
 - where the work / product is to be delivered etc
- b) If a written specification has been issued the assessment criteria is to be included in the written specification.
- c) In any event, assessment criteria are to be determined prior to evaluation – How the submission is to be assessed and scored, and may include –
- Details and record to be appropriate to the procurement
 - Local provider or external
 - Standard of work, quality of item
 - Reliability, service, warranty
 - References
 - Price etc
- d) After close of submission period, evaluation is to be made based on the following– How the submission was actually assessed and scored –
- To what extent was each specification met,
 - How does submission measure against each criteria
 - Which score provides best value for money

Where required and prior to submissions being requested, the specifications for the procurement and the assessment criteria for determining the procurement are to be determined in writing –

- for quotations – by the purchasing employee, and approved by the relevant Executive Manager within their approved purchasing limits, otherwise by the CEO
- for tenders – by the purchasing employee, approved by the relevant Executive Manager, and authorised by the CEO under delegated power.

If required or appropriate, any Evaluation Panel is to be established prior to the request for submissions being with a mix of skills and experience relevant to the nature of the purchase. The Panel is to assess the submissions against the specifications set, the assessment criteria, value for money, local price preference and any other relevant matter.

– End of Schedule

Policy Schedule 3.1(c) – Regulatory Compliance

1. Tender Exemption

In some instances public tenders or quotation procedures are not required, regardless of the value of expenditure. The permitted exemptions are stipulated in the Local Government (Functions and General) Regulations 1996 r.11.

2. Sole Source of Supply (Monopoly Suppliers)

- a) Procurement from only one private sector source of supply, (i.e. manufacturer, supplier or agency) is permitted without the need to call competitive quotations provided that –
 - there must genuinely be only one source of supply
 - every endeavour to find alternative sources has been made,
 - written confirmation of this must be kept on file for later audit.
- b) The application of provision “sole source of supply” should only occur in very few cases and procurement experience indicates that generally more than one supplier is able to provide the requirements.
- c) Purchase orders issued to a sole supplier are to be signed –
 - where the purchase is \$10,000 or more – by the CEO.
 - where the purchase is less than \$10,000 ex GST – by the CEO or relevant Executive Manager.

3. Anti-Avoidance

The Shire shall not enter two or more contracts of a similar nature for the purpose of splitting the value of the contracts to take the value of consideration below the level of \$250,000, thereby avoiding the need to publicly tender.

4. Tender Criteria

- a) The CEO under delegated power shall, before tenders are publicly invited, determine in writing the criteria for deciding which tender should be accepted.

5. Receiving and Opening Tenders

- a) All tenders must be clearly marked, sealed and placed in the locked tender box until the official opening.
- b) When lodgement of tenders by email is permitted, the email is to be sent to a separate email inbox that remains unused until the close of the tender period.
- c) When tenders are opened there must be at least two employees present, or one local government employee and at least one person authorised by the CEO.

6. Tender Evaluation

- a) Evaluation is to be recorded against the specifications set and assessment criteria established. Reasons for the decision are to be recorded.
- b) Where required by Schedule 3.1(b) an evaluation panel will be established and include a mix of skills and experience relevant to the nature of the purchase.

7. Tender Acceptance

Unless authorised by Council, and delegation of acceptance has been made to a specific Committee or the CEO, all tenders and procurement over \$250,000 are to be presented to Council for decision.

8. Records Management

- a) All records associated with the procurement process must be recorded and retained. For a tender process this includes –
 - Tender documentation, including specifications and assessment criteria,
 - Internal documentation,
 - Evaluation documentation,
 - Enquiry and response documentation,
 - Notification and award documentation.
- b) For a direct purchasing process this includes –
 - Quotation documentation, including any specification and assessment criteria
 - Internal documentation, such as evaluation etc
 - Purchase orders issued and requisitions.

- c) Record retention shall be in accordance with the minimum requirements of the State Records Act, and the Shire's internal records management policy.

– End of Schedule

3.2 Purchasing – Regional Price Preference

Statutory context Local Government (Functions and General) Regulations 1996 –

- r.24B – terms used
- r.24C – authority to adopt a policy
- r.24D – maximum % discount and maximum \$ value of discount permitted
- r.24E – once prepared, Statewide notice is required, submissions invited, and if significant changes made, further Statewide notice
- r.24F – Policy can't be adopted until after Statewide notice of adoption, and specified matters must be in the policy, and the policy must be included in tender specifications

Corporate context Delegation 3.1 – Tenders – authority to set specifications, criteria, call, accept, vary
Delegation 3.2 – Contracts - Variations

[Code of Conduct – Employees](#)

Executive Instructions –

- 3.1 – Purchasing – Documentation
- 3.3 – Credit (Transaction) cards

History

Adopted	26 April 2017
Last reviewed	24 July 2019
Last reviewed	7 June 2021

Policy Statement

1. The following Council Policy Schedules are adopted, and form part of this Statement –
 - Policy Schedule 3.2 – Regional Price Preference.
2. The Regional Price Preference applies to providers and suppliers –
 - a) established within the preference region,
 - b) based outside the preference region.
3. This Policy applies to all purchasing and procurement activity, and is not limited to tendering.

– End of Policy

Notes

Statutory requirement –

The Functions & General Regulations require –

- **Statewide notice of proposed policy, amendment or revocation,**
- **public comment period of 4 weeks,**
- **submissions considered prior to adoption, and**
- **Statewide notice of adoption.**

Advertised on 22 August 2019 (West Australian & Narrogin Observer)

Policy Schedule 3.2 – Regional Price Preference

1. Definitions

price preference is the application of a discount to the price when comparing submitted prices only, so as to give a marginal advantage to a regional offer, and does not refer to the price that is to be accepted.

preference region is specified as the geographical area which comprises the whole of the Shires of Narrogin, Cuballing, Wickepin, Williams, Wagin and West Arthur.

regional tenderer as defined under the *Local Government (Functions and General) Regulations 1996 s 24B(2)* as a supplier that has been operating a business continuously out of premises within the region for at least 6 months and submits a tender for the supply of goods and/or services.

start up businesses means a business of less than 10 employees, which has commenced within the preceding 6 months prior to closing date of tender, or would be established specifically for the purposes of the tender.

regional content preference is the incentive for businesses/contractors outside the region to purchase goods, services and construction from within the region, but excludes travel and accommodation costs.

tenderer includes a new or start up business where the owner or provider has been resident of the region for at least 6 months.

2. Preference principles

The Shire will encourage local industry to do business with the Shire by providing incentive through the adoption of a regional price preference advantage in conjunction with standard evaluation considerations, and as part of usual procurement consideration.

The price preference will apply to suppliers who are based in, and operate from the preference region in relation to all purchasing by the Shire for the supply of goods and services and construction (building) services, unless specifically stated otherwise, providing they are competitive in regard to specification, service, delivery and price.

3. Start-up Businesses

Where a new or start up business having less than 10 employees makes a submission, the anticipated longevity of the business, its relevance to the region and if goods or service previously not available in the region, are to constitute a component of "value for money" or "most advantageous" considerations as per Function and General Regulations r.24D(3). Reasons are to be itemised, and detailed as part of the "value for money" evaluation in accordance with Policy Sch.3.1(a) – Purchasing Principles.

4. Regional business preference

This preference enables businesses/contractors within the preference area to claim a price preference for their whole bid, regardless of the origin of the labour or materials, as all labour and materials are deemed to be regional content.

The following levels of preference are to be applied to whole of contract for all purchasing under this provision –

Reduction % to be applied to whole of purchase	Contract for	Maximum reduction value per purchase
10%	Goods or services	\$30,000
5%	Construction (incl. building and roadworks etc) services	\$50,000

To qualify as a local business/contractor, a supplier must meet the following conditions –

- a) A permanent business location in the preference region for at least six (6) months. *Local Government (Functions and General) Regulations 1996* states that the 6 month calculation is based on the period prior to when the tender closes.
- b) Have permanent staff based in the preference region
- c) Management and delivery of the majority of the quotation / contract will be carried out from their business location in the preference region.

The price of the bids from the local businesses/contractors will be reduced / discounted for evaluation purposes only, by the percentage to the maximum value set out in this clause.

5. Regional Content Preference

Some businesses / contractors may be based outside the preference region, but utilise significant resources based in the preference region. This preference provides an incentive for businesses / contractors outside the preference region to purchase goods, services and construction from within the preference region.

The preference applies to the value of the goods, materials or services that are purchased from within the preference region, and are referred to as *Regional Content*.

The following levels of preference are to be applied to the portion of the proposal claimed / identified as the Regional Content portion of the contract for all purchasing under this policy –

Reduction % to be applied to Regional Content only of purchase	Contract for	Maximum reduction value per purchase
10%	Goods or services	\$30,000
5%	Construction (incl. building and roadworks etc) services	\$50,000

Regional content limitations for suppliers based outside the preference region are –

- a) some or all of the goods, materials or services are to be supplied from regional sources. The preference only applies to that part of the tender or quote that has been supplied from regional sources, which needs to be specified in the submission.
- b) businesses outside of the preference region who claim that they will use regional business in the delivery of the contract outcomes
 - must stipulate who the regional provider will be and the value of the regional content, and
 - will be required as part of the contract conditions, to demonstrate that they have actually used the regional provider.

The price of the bids from the businesses/contractors using preference region content will be reduced for evaluation purposes and for that component of the bid only, by the amounts set out in above.

6. Scope

It should be noted that price is only one factor to be considered when the Shire assesses submissions. Accordingly, a regional submission where price is within the preference is not guaranteed of procurement, as the submission must also meet other relevant criteria, as per Policy 3.1 – Purchasing Framework.

– End of Schedule

3.3 Self-Supporting Loans

Statutory context Local Government Act 1995 –
- s.6.20 – Power to borrow
- s.6.21 – Restrictions on borrowing

Local Government (Financial Management) Regulations 1996
- r.20 – When local public notice not required for exercise of power to borrow

Corporate context None

History Adopted 26 April 2017
Last reviewed 24 July 2019
[Last reviewed 7 June 2021](#)

Policy Statement

1. A request to Council to raise a self-supporting loan will be considered only from community or not for profit organisations.
2. Each request will be considered on its merits, and the organisation may be asked to provide guarantors or other acceptable security.
3. In the event of Council agreeing to make funds available on a self-supporting basis, Council reserves the right to control and/or to carry out any of the following –
 - a) the preparation of plans and specifications for the proposed work,
 - b) the calling of tenders for the proposed work,
 - c) the preparation of the contract documents,
 - d) the letting of the contract,
 - e) sole supervision of the project,
 - f) sole authorisation of expenditure of funds for the project.

– End of Policy

Notes

3.4 Ex-Gratia Payments

Statutory context	None
Corporate context	Delegation 3.12 – Ex-gratia payments
History	Adopted 26 April 2017 Last reviewed 24 July 2019 Last reviewed 7 June 2021

Policy Statement

1. The Shire exercises a predisposition against making ex-gratia payments.
2. All claims are to be referred to the Shire's insurers.
3. Exceptional circumstances may be referred to Council for consideration, noting that such a referral does not constitute likelihood of Council agreement.
4. When referring to Council, the report is to advise –
 - of all attempts to claim insurance, if applicable,
 - circumstances outside of the Shire or claimant's control, that may contribute to consideration of the claim.
5. Should Council agree to make an ex-gratia payment, the claimant is to be –
 - a) made an offer in writing,
 - b) advised –
 - the offer is without prejudice
 - does not constitute a precedent
 - does not imply admission of liability
 - c) required to confirm that no further claim will be made on the Shire in relation to the matter.
6. Only once (5) above is fully completed is payment to be made.

– End of Policy

Notes

3.5 Rates – Prize Eligibility

Statutory context Local Government Act 1995

Corporate context None

History

Adopted	26 April 2017
Amended	24 July 2019
<u>Amended</u>	<u>23 June 2021</u>

Policy Statement

1. In order to qualify for rates incentive prize, payment of rates must be processed prior to close of business hours on the due date.
2. Entry to the prize draw will not be allowed after this time and date in any circumstances.
3. The monetary value of the rates incentive prizes offered are to be determined in the relevant Budget.
4. The prizes are to be drawn by the elected head of Council within 2 weeks of the due date.

5. Those not eligible to participate, are –
a) Key Management Personnel as defined in Policy 1.10 Related Party Disclosures; and
b) State or Commonwealth Government agencies.

– End of Policy

Notes

Deleted: Key Management Personnel as defined in Policy 1.10 Related Party Disclosures are not

Deleted: CEO Note: For next policy manual review, add in Part V the ineligibility of State or Commonwealth Government agencies.¶

3.6 Rating – Merger Parity Transition

Statutory context	Local Government Act 1995
Corporate context	Memorandum of Understanding – former Shire and Former Town of Narrogin
History	Adopted 26 April 2017 Last reviewed 7 June 2021

Policy Statement

1. Memorandum of Understanding

Council confirms the agreement of the Memorandum of Understanding made between the former Shire of Narrogin and former Town of Narrogin and signed in March 2015, and applying from the 2016/17 Budget as follows –

4.16 Rating – Parity Factor

It is agreed that to achieve parity of rating within the GRV and UV individual categories that –

- a) Calculation of the “parity factor” will be on the basis of a fixed base-line year of 2015/2016 using the principles outlined in the Proposed Merger Report of February 2014.
- b) The “parity factor” is to be applied to each rate category over an appropriate period, so that –
 - Equity in the New Entity is achieved for the GRV category, and
 - “Parity factor” for the UV category is calculated with the Shire of Wagin as the selected comparative Shire, and updated from the 2015/2016 Budgets.
- c) After application of the “parity factor”, the “natural increase” that is generally consistent across all rates categories and type be applied only to the extent necessary to meet budget requirements.
- d) The parity factor does not necessarily mean equality of rate in \$, but what is considered to be a reasonable and appropriate level considering access to amenities, facilities used and services provided.
- e) A Joint Merger Policy is to be prepared for the calculation of parity factor increase for each rate category and is to take into account that –
 - The % rates quoted on the Report and below are referenced to the Comparison Year, and are to be considered as indicative,
 - The % rate referenced to the Base Line Year is to provide for the annual cumulative effect over the period phased in.
- f) The concepts of “parity factor” and “natural increase” are to be used as the methodology to calculate a cumulative rate in \$ for each individual prescribed attribute/zoning for which a differential rate/\$ is to apply, and not implemented as a two tier differential rate in \$.

Report Comparison Year 2013-2014		Base-Line Year 2015/2016
Annual Parity Factor Over 10 Years		Annual Parity Factor Over 10 Years
3.9%	UV – Rate in \$	To be re-calculated and inserted once 2015/2016 Budgets adopted by – - Shire of Narrogin - Town of Narrogin - Shire of Wagin
7.8%	UV – Minimum	
10.5%	GRV – Rate in \$	
7.8%	GRV – Minimum	
3.3%	GRV – Rural Townsite Minimum	

4.17 Rating – Unimproved Values

- a) Unimproved rates should be increased –
 - Annually, by the parity factor as calculated for Base Line Year in 4.16 above,

- The factor as calculated at that date, together with any natural increase annually, is intended to be applied equally over a period of 10 years.
- b) The parity factor is set from the 2015/2016 calculation and is not designed to achieve the same rate in \$ with the Shire of Wagin either annually or at the end of the 10 year period.

4.18 Rating – Gross Rental Values

- a) Differential rating provisions will be utilised to phase in and maintain, an equitable level of rating across the New Entity.
- b) As a new Local Planning Scheme will apply the same zoning to land in the Shire as in the Town, Governor’s Orders should include the capacity for differential rating on the basis of location in the former Shire or former Town, should the New Entity choose to exercise this option.
- c) It is agreed that the provisions of the Financial Management Regulation r.52A(2) should be used for the five years permitted to achieve 50% of the calculated “parity gap”.
- d) Subject to any Governor’s Order issues pursuant to clause 4.16(1), it is further agreed that following the 5 year period permitted by Financial Management Regulation r.52A(2), the differential rating provisions in the Act should be used for a further 5 year period to address the remainder of the “parity gap”.
- e) The intent of differential rating of GRV properties is to phase in rate increases of similarly zoned land –
 - Annually, by the parity factor as calculated for Base Line Year in 4.16 above,
 - The factor as calculated at that date, together with any natural increase annually, is intended to be applied equally over a period of 10 years,

2. Parity Factors

Parity factors calculated in May 2016 for properties in the former Shire of Narrogin, in accordance with the MOU and used for differential rating in 2016/2017 Budget –

Annual Parity Factor - Compounding % Increase	2015/2016 Rate/\$	2015/2016 Target Rate/\$	Total Parity % Increase	Years for phase in	Annual Increase Compounding %
Unimproved Value	0.005500	0.007545	37.2%	10	3.21%
Minimum	590.00	1,006.00	70.5%	10	5.48%
Gross Rental Value	0.051500	0.10057	95.3%	10	6.92%
Minimum	590.00	1,006.00	70.5%	10	5.48%
Minimum – Rural Townsite (75%)	590.00	754.50	27.9%	10	2.49%

– End of Policy

Notes

Memorandum of Understanding

The MOU signed in March 2015 formed the foundation of the agreement between the former Shire and the former Town. A critically important component of that agreement was the process for achieving rating equitability between the two former local governments, as outlined above.

Parity Factor

As per the MOU, the parity factor was recalculated on the basis of the 2015/2016 rate increases of the relevant local government, and incorporated into the calculation of the differential rating proposal put to the Town of Narrogin Council on 10 May 2016, advertised in accordance with the Governor’s Order and subsequently adopted.

Note – 2015/16 Unimproved Value Target Rate/\$ is that of Shire of Wagin as per MOU

3.7 Investments

- Statutory context** *Local Government Act 1995* –
- s.6.5(a) – Chief Executive Officer duty to ensure that proper accounts and records of the transactions and affairs are kept in accordance with regulations.
 - s.6.9(2) – interest on monies held in Trust is to be applied to the purpose of the monies held
 - s.6.14 – money held in trust may be invested under *Trustees Act 1962* Part III

- Local Government (Financial Management) Regulations 1996* –
- r.8 – money from different accounts may be placed in a common investment
 - r.19 – control procedures for investments required
 - r.19C – restrictions on investments prohibited –
 - o deposits with institutions not authorised
 - o fixed term of more than 12 months
 - o bonds not guaranteed by Commonwealth State or Territory
 - o bonds with maturity term more than 3 years
 - o foreign currency

- Banking Act 1959 (Commonwealth)*
- s.5 – definition of *authorised deposit taking institution*
 - s.9(3) – authority to carry on a banking business

- Trustees Act 1962* –
- Part III - Investments

Western Australian Treasury Corporation Act 1986

Corporate context Delegation 3.10 – Investments

History

Adopted	26 September 2018
Amended	24 July 2019
Last reviewed	7 June 2021

Policy Statement

1. Approval to invest

Surplus funds to immediate requirements may be deposited into an authorised institution, in accordance with *Local Government (Financial Management) Regulations 1996* r.8, 19 and 19C.

2. Prudent Person Standard

The investment will be managed with the care, diligence and skill that a prudent person would exercise. Employees are to manage the investment portfolios to safeguard the portfolios in accordance with the spirit of this Policy, and not for speculative purposes.

3. Ethics and Conflicts of Interests

Employees shall refrain from personal activities that would conflict with the proper execution and management of the local government's investment portfolio. The Department of Local Government Sporting and Cultural Industries Guidelines No.1 "*Disclosure of Interests Affecting Impartiality*" and No.21 "*Disclosure of Financial Interests in Returns*" provide guidance for recognising and disclosing any conflict of interest. Any independent advisors are required to disclose any actual or perceived conflicts of interest.

4. Approved Investments

Investments may only be made with authorised institutions as follows –

- a) an authorised deposit-taking institution as defined in the *Banking Act 1959* (Commonwealth) section 5 with a Standard & Poor's (or its equivalent) credit rating of BBB or higher; or
- b) the Western Australian Treasury Corporation established by the *Western Australian Treasury Corporation Act 1986*.
- c) bonds that are guaranteed by the Commonwealth or a State or Territory and which have a term not exceeding three years.

5. Prohibited Investments

Investments which are not allowed are as follows –

- deposits with an institution except an authorised deposit-taking institution in accordance with the *Banking Act 1959*;
- deposits for a fixed term of more than 12 months;
- stand-alone securities issued that have underlying futures, options, forward contracts and swaps of any kind; or
- are in a foreign currency.

6. Professional Advice

The Shire may from time to time retain the services of suitably qualified investment professionals to provide assistance in investment strategy formulation, portfolio implementation and monitoring.

Any such independent advisor must be approved by Council and licensed by the Australian Securities and Investment Commission. The advisor must be an independent person who has no actual or potential conflict of interest in relation to investment products being recommended and is free to choose the most appropriate product within the terms and conditions of this investment policy.

Any independent advisor engaged by the Shire is required to provide written confirmation that they do not have any actual or potential conflicts of interest in relation to the investment they are recommending or reviewing, including that they are not receiving any commissions or other benefits in relation to the investments being recommended or reviewed.

7. Investment Funds

All cash and investments held by the Shire are placed in common investments in accordance with *Local Government (Financial Management) Regulation 1996* Regulation 8.

8. Risk Management Guidelines

Investments are restricted to bank investments only. The term of the investment will be based on forward cash flow requirements to ensure investment return on available surplus funds.

All investments obtained must comply with three key criteria relating to –

- Portfolio Credit Framework limit overall credit exposure of the portfolio
- Counterparty Credit Framework: limit exposure to individual counterparties/institution; and
- Term to Maturity Framework: limits based upon maturity of securities.

Portfolio Credit Framework

To control the credit quality on the investment portfolio, the following credit framework limits the percentage of the portfolio exposed to any particular credit rating category.

S&P Long Term Rating	S&P Short Term Rating	Direct Investment Maximum
AAA	A-1+	100%
AA	A-1+	100%

A	A-1	60%
BBB	A-2	20%

If any of the investments within the portfolio are subject to a credit rating downgrade such that the portfolio credit percentage are no longer compliant with the Investment Policy, the investment will be diverted as soon as practicable.

Counterparty Credit Framework

Exposure to an individual counterparty/institution will be restricted by its credit rating so that single entity exposure is limited, as detailed in the table below –

S&P Long Term Rating	S&P Short Term Rating	Direct Investment Maximum
AAA	A-1+	50%
AA	A-1+	50%
A	A-1	20%
BBB	A-2	10%

If any of the investments within the portfolio are subject to a credit rating downgrade such that the portfolio credit percentage are no longer compliant with the Investment Policy, the investment will be diverted as soon as practicable

Term to Maturity Framework

The investment portfolio is to be invested within the following maturity constraints –

Investment type	Term to Maturity
Authorised Deposit-taking Institution Deposits	< 12 months
State/Commonwealth Government Bonds	< 3 years

9. Reporting and Review

A monthly report on the investment portfolio is to be made to the Council, listing for each investment the institution, amount, term to maturity, maturity date, amount interest rate, and % of total portfolio represented by the individual investment. A summary of the composition of the investment portfolio by credit rating and institution will also be included.

– End of Policy -

Notes

The Local Government Act requires that money invested under the Trustees Act comply with the Regulations.

3.8 Transaction Cards

Statutory context

Local Government Act 1995 –

- s.6.5(a) – Chief Executive Officer duty to ensure that proper accounts and records of the transactions and affairs are kept in accordance with regulations.

Local Government (Financial Management) Regulations 1996 –

- r.5, the Chief Executive Officer's duties to ensure efficient systems and procedures are established for the proper authorisation of incurring of liabilities and the making of payments.
- r.11(1)(a) and (2) – requirement to develop procedures that ensure effective security for the authorisation and payment of accounts and for the authorised use of payment methods, including transaction cards.

Corporate context

Policy 3.1 – Purchasing Framework

[Code of Conduct – Employees](#)

Executive Instruction 3.3 – Transaction Card Procedures

History

Adopted 26 September 2018

Amended 24 July 2019

[Amended 23 June 2021](#)

Policy Statement

All cardholders must have the authority of the Chief Executive Officer to commit Council to expenditure.

1. Definitions

Cardholder means an employee who has been authorised by the Chief Executive Officer to incur expenditure by means of a transaction card.

Transaction Card means a card facility (which may include; credit, debit, store, parking, cab-charge and fuel cards) approved for use in lieu of cash transactions, to incur expenditure for goods and services for the purposes of the Shire of Narrogin business activities only in accordance with relevant Shire policies.

2. Determining When Transaction Card Facilities are Appropriate

- Transaction Card facilities may be implemented and maintained where the card facility provides benefit to the Shire of Narrogin operations by ensuring –
 - goods and services can be obtained in a timely and efficient manner to meet the business needs of the Shire;
 - financial management and accounting standards are met; and
 - purchasing and payment functions are secure, efficient and effective.
- Transaction card facility providers will only be acceptable where, in the opinion of the Chief Executive Officer, they –
 - provide appropriate and sufficient statement, administration and acquittal controls that enable the Shire to sufficiently administer the facility; and
 - provide the Shire with protection and indemnification from fraudulent unauthorised transactions.

3. Management Oversight

The Chief Executive Officer shall determine and implement systems and procedures that are adequate to ensure –

- assessment and selection of transaction card facilities suitable to the efficient and effective operations of the Shire;
- authorisation and appointment of suitably eligible cardholders;
- cardholder duties and responsibilities are documented; and
- cardholders provided with training; and
- monitoring and auditing of transactional card activities is planned and reported.

4. Reporting

The Chief Executive Officer will ensure that acquitted transaction statements for each transaction card facility are provided to Council as part of the monthly financial reporting regime.

5. Misuse, Misconduct and Fraudulent Use

- a) Any alleged misuse of transaction cards will be investigated, and may be subject to disciplinary procedures.
- b) Where there is reasonable suspicion of misconduct or fraudulent activity arising from transaction card facilities the matter will be reported to the appropriate regulatory agency, subject to the requirements of the *Public Sector Management Act 1994* and the *Corruption, Crime and Misconduct Act 2003*.

6. Principles for usage – Allowable transactions

- a) Transaction card facilities may only be used where –
 - i) the expenditure is directly arising from a Shire operational business activity for which there is an Annual Budget provision;
 - ii) the expenditure is in accordance with legislation, the Shire Purchasing Policy, Code of Conduct [for Employees](#) and any conditions or limitations applicable to the individual Cardholder.
 - iii) the procurement of the required goods or services is impractical or inefficient if undertaken via a purchase order or is not able to be obtained other than by a transaction card;
 - iv) supplier surcharges (fees) on transactions are minimised and only allowable where the alternative method of obtaining the supply (i.e. by purchase order) is more onerous, not cost effective or there is no alternative mode of supply.
 - v) hospitality expenditure may only occur when it is in accordance with any Shire Hospitality Policy or is undertaken with the express permission of the Chief Executive Officer.
 - vi) official travel, accommodation and related expenses may only occur in accordance with Shire policies and procedures;
 - vii) a sufficient record of each transaction is obtained and retained in the local government record.
- b) Allowable transaction modes include –
 - i) in-person and over the counter retail purchases;
 - ii) telephone or facsimile purchasing;
 - iii) mail order purchasing and subscriptions;
 - iv) internet purchasing.

7. Principles for usage – Prohibited transactions

- a) The Shire prohibits the use of transaction card facilities for –
 - i) cash advances;
 - ii) incurring expenses which are personal or private (i.e. any expenditure which is not an approved local government activity);
 - iii) making deposits onto the card, whether to offset misuse or otherwise;
 - iv) incurring capital expenditure;
 - v) incurring expenditure for goods or services which are subject to a current supplier contract;
 - vi) incurring expenses which are not in accordance with legislation, the Shire's Purchasing Policy, the Annual Budget and / or the conditions or limitations relevant to the individual cardholder;
 - vii) expenses for which another transaction card is the approved facility – eg.: a corporate credit card is not to be used for purchasing fuel or oil, as the fuel card is the approved facility for that purpose;
 - viii) splitting expenditure to avoid compliance with the Purchasing Policy or to negate limits or conditions applicable to the Cardholder; and
 - ix) incurring expenses for the primary purpose of obtaining personal advantage through the transaction (i.e. membership or loyalty rewards).
- b) For clarity, elected members are prohibited from using Shire transaction cards as the *Local Government Act 1995* does not provide authority for an elected member to incur liabilities on behalf of the local government. The Act limits local governments to only paying elected member allowances and reimbursing elected member expenses.

8. Cardholder duty of care and responsible use obligations

- a) A cardholder is required to –
 - i) keep the transaction card and access information in a safe manner; protected from improper use or loss.
 - ii) only use the transaction card for allowable purposes and not for prohibited purposes.
 - iii) obtain, create and retain local government records that evidence transactions.

- iv) acquit the reconciliation of transaction card usage in the required format and within required timeframes. The onus is on the cardholder to provide sufficient detail for each transaction to avoid any potential perception that a transaction may be of a personal nature.
 - v) return the transaction card to the Shire before termination of employment, inclusive of reconciliation records.
 - vi) reimburse the Shire the full value of any unauthorised, prohibited or insufficiently reconciled expenditure.
 - vii) Comply with all cardholder responsibilities as outlined by the card provider.
- b) Benefits obtained through use of a transaction card (i.e. membership or loyalty rewards) are the property of the Shire and may only be used for Shire business purposes. Such benefits must be relinquished by the cardholder to the Shire. Under no circumstances may such benefits be retained as a personal benefit.
9. Transaction evidence
- a) A sufficient transaction record must include the following minimum information – p
- i) invoice and / or receipt that includes; the date, company name, address, ABN, amount and any GST amount included;
 - ii) where an invoice and / or receipt cannot be obtained, the cardholder must provide a signed statement, detailing the nature of the expense and sufficient information to satisfy the requirements of subclause (i) above.
 - iii) approval of the expense in (ii) above is to be referred to the Chief Executive Officer for a decision.
- b) Where a transaction card is used to incur an expense for hospitality, the transaction record must include for the purposes of Fringe Benefits Tax calculations and probity –
- i) the number of persons entertained;
 - ii) the names of any employees in that number; and
 - iii) the purpose of providing the entertainment or hospitality.
10. Card Reconciliation Procedures
- a) Card statement accounts will be issued to the relevant cardholder who will, within 7 days, acquit the transactions on the account.
 - b) Transactions will be supported by a GST invoice stating the type of goods purchased, amount of goods purchased and the price paid for the goods. The receipt shall meet the requirements of the *Goods and Services Tax Act 1999* to enable a GST rebate to be applied.
 - c) Transactions shall be accompanied by a job number for costing purposes.
 - d) Should approval of expenses be refused by the Chief Executive Officer recovery of the expense shall be met by the cardholder.
 - e) The cardholder shall sign and date the card statement with supporting documentation attached stating all expenditure is of a business nature.
11. Disputed Transactions
- a) The Shire is responsible for paying all accounts on the monthly card statement and the bank processes a direct debit from Council's operating bank account for such.
 - b) When a Cardholder believes that charges are incorrect they should first contact the supplier to determine the causes of the discrepancy and if necessary the Creditors Officer will notify the bank in writing.
 - c) Any amounts in dispute must be highlighted on the copy of the Cardholders statement and a copy of the written notification to the bank attached.
12. Cancelled Cards
- Cancellation of a Card may be necessary where the –
- a) cardholder changes job function within the local government;
 - b) cardholder terminates employment with local government;
 - c) the employment of the Cardholder is terminated;
 - d) card is no longer required;

- e) cardholder has not adhered to set procedures;
- f) misuse of the Card; or
- g) other sufficient reason in the opinion of the CEO.

13. Review of Card Use

All receipts and documentation will be reviewed and any expenses that do not appear to represent fair and reasonable business expenses shall be referred to the Chief Executive Officer for a decision.

14. Procedures for Lost, Stolen and Damaged Cards

- a) The cardholder must formally advise the Executive Manager Corporate & Community Services of the loss or theft without delay.
- b) The loss or theft of a transaction card must be reported to the card provider as a matter of priority.
- c) Advice of a damaged card is to be provided to the Executive Manager Corporate & Community Services who will arrange a replacement.

15. Additional Cardholders

- a) The Chief Executive Officer is the primary cardholder for the Shire and may authorise additional cardholders within the Shire's approved total credit limit.
- b) Individual transaction card limits are as approved by the CEO.

16. Cardholder Agreement

- a) The Cardholder Agreement is as determined by the CEO.
- b) Failure to comply with any of these requirements could result in the card being withdrawn from the employee.
- c) In the event of loss or theft through negligence or failure to comply with the Shire of Narrogin Card Policy any liability arising may be passed on to the cardholder.

17. Consequences of Non-Compliance

Failure to comply with the Delegations, Policy or Executive Instructions may result in disciplinary action up to and including termination of employment.

– End of Policy

Notes

3.9 Complaints Management

Statutory context N/A

Corporate context

[Policy Manual](#)

[1.1 – Code of Council](#)

[Code of Conduct for Employees](#)

History	Adopted	20 December 2018
	Amended	24 July 2019
	Amended	23 June 2021

Deleted: N/A

Policy Statement

Objectives

1. To develop a structured systematic approach to dealing with complaints received by the Shire of Narrogin from external persons.
2. To assure the community that complaints may be made without fear of recrimination and that all complaints will be promptly dealt with and a (written if required) response will be given setting out the answer to the complaint providing reasons, where appropriate.
3. To have complaints dealt with efficiently by an appropriate employee with minimal referral.
4. To use complaints statistics to improve the effectiveness and efficiency of Shire operations.

Definition

5. A complaint is –
“an expression of dissatisfaction made to or about an organization, related to its products, services, staff or the handling of a complaint, where a response or resolution is explicitly or implicitly expected or legally required”
(as defined by the *AS/NZS 10002-2014 Guidelines for Complaint Management in Organisations*).

Policy

6. The Shire of Narrogin recognises the right of its customers to make complaints about services or service delivery, and will make it a priority to address those complaints and rectify unsatisfactory consequences.
7. The Council and its staff will be open and honest in its dealings with customers.
8. When unable to satisfy the complaint, an explanation will be provided in “plain English” why, for legislative/legal reasons, cost constraints or some other matter beyond its control, it is unable to act in accordance with a complainant’s request.
9. The Shire recognises that good complaints handling is an integral part of customer service and provides an effective way of reviewing performance and monitoring standards.
10. The Shire may determine to take the following courses of action –
 - a) take no further action and advise the complainant of the reason/s;
 - b) determine the complaint by use of appropriate strategies such as, but not limited to, mediation, informal discussion or negotiation;

- c) discontinue the assessment in circumstances where it becomes evident that the matter would be referred to another body or person and advise the complainant accordingly.

Confidentiality

- 11. Complainants have the right to expect that their privacy will be respected when making a complaint or having a complaint investigated. Personal information related to the complaint will be kept confidential in accordance with the *Freedom of Information WA Act 1992*.
- 12. All complaints are treated confidentially, unless required by law or the complainant provides their permission to release information.
- 13. A complaint against an employee is considered confidential under the *Freedom of Information Act 1992* and the complainant will not be advised of the outcome, unless required by law.

Application

- 14. Complaints that are to be dealt with under this policy include, but are not necessarily limited to, expressions of dissatisfaction regarding –
 - a) decisions made by Council or staff;
 - b) inappropriate behaviour of staff or members such as rudeness, discrimination or harassment;
 - c) the standard of works or services provided by the local government;
 - d) the standard or condition of a facility provided by the local government; and
 - e) failure of the local government to comply with the Local Government Act, Council policies, local laws and other laws administered by the local government.
- 15. The following issues are not regarded as complaints and will not be dealt with under this policy –
 - a) requests for services;
 - b) compliance enforcement action;
 - c) a civic dispute between private individuals;
 - d) a petition;
 - e) requests for information or explanations of policies and/or procedures;
 - f) the lodging of a formal objection or appeal in accordance with the Local Government Act and other Acts or in accordance with Council policies or standard procedures; and
 - g) the lodging of a submission in response to an invitation for comment.
- 16. Complaints regarding elected members are to be directed to the CEO who is responsible for the initial investigation and administrative responses. Matters that may require disciplinary action are to be referred to the Shire President and dealt with under the [Policy 1.1](#) Code of Conduct.
- 17. Complaints from Councillors, the Ombudsman, the Local Government Department or from Members of Parliament shall be referred to, and dealt with by, the CEO unless the complaint relates to the CEO whereupon the complaint will be dealt with by the Shire President.

Deleted: Council's

Guidelines

- 18. Any person or their representative can lodge a complaint.
- 19. Complaints will be accepted in writing, in person, by facsimile transmission, by email or by telephone. If a verbally received complaint alleges a criminal offence, corruption or other serious matter, the receiving employee is to advise the complainant that the matter must be submitted in writing.
- 20. Complainants are to be advised that anonymous complaints may not be processed as it is possible that they may be mischievous or vexatious. Depending on the nature of the complaint, it will be at the discretion of the receiving employee to act or refer the complaint or not to deal with the complaint.

21. When any complaint is made, other than a complaint referred to in clauses 16 or 17, the designated receiving employee shall, within the limit of their authority, attempt to satisfy the complainant as soon as possible. If a complainant cannot be satisfied immediately, or on the same day, the designated receiving employee shall immediately issue to the complainant a written acknowledgement of the complaint and if need be, refer to the complaint and a copy of the acknowledgement to a senior employee, or the CEO, as is appropriate, for investigation and determination of the complaint.
22. The standard response times when dealing with complaints are those in the Customer Service Charter.
23. Where a complainant is advised of a likely delay to the handling of the complaint and the complaint is not finalised within a reasonable period of time, the complainant is to be provided with status reports from time to time until the complaint is satisfied.
24. The CEO shall establish and maintain an appropriate record of all complaints. The record will provide the following –
 - a) nature of each complaint;
 - b) services or facilities about which the complaints are made;
 - c) outcomes; and
 - d) other relevant information.
25. The designated receiving employee of any complaint shall be responsible for ensuring that all details pertaining to the complaint are recorded in the system established under clause 24.

Outcomes

26. Where a complaint has been investigated and found to be justified, the relevant employee who dealt with the complaint will ensure that the remedy is carried out, will advise the complainant that the Shire does acknowledge substance in the complaint and the specific action that will be taken by the Shire to respond to the circumstances of the complaint. The employee will, if appropriate, make follow-up contact with the complainant to ensure that the complaint has been resolved satisfactorily.
27. Where a complaint may identify the need for a review of procedures to prevent re-occurrences, relevant staff are to implement any required changes which they feel appropriate. If the matter cannot be easily remedied by the employee, he or she must liaise with his/her Manager or the CEO to agree on a course of action.
28. Where the complaint identifies a need for a change of Council policy in a particular area or a need for additional resources, the matter shall be referred to Council as early as practicable.
29. Where appropriate or necessary, the CEO or relevant Executive Manager may refer the complaint to an external agency having jurisdiction in the matter.

Dealing with unreasonable complainant conduct

30. An unreasonable complainant is defined as the following –
 - a) a rude, angry and harassing customer;
 - b) an aggressive customer;
 - c) habitual or obsessive behaviour which may include –
 - i) cannot 'let go' of their complaint;
 - ii) cannot be satisfied despite the best efforts of the Shire;
 - iii) makes unreasonable demands on the local government where resources are substantially and unreasonably diverted away from its other functions or are unfairly allocated.
31. The Shire may restrict, withhold or withdraw the provision of service to unreasonable complainants by taking one of the following actions –
 - a) require the complainant to make an appointment to meet with employees;

- b) limit all future dealings to writing;
- c) only respond to future correspondence which provides significant new information about the complaint or raises new issues which the Shire believes warrant fresh action; and
- d) direct all contact to be through a specific employee or area.

32. The decision to determine an unreasonable complainant or to restrict, withhold or withdraw contact with the Shire will only be made by the Chief Executive Officer.

– End of Policy

Forms and Templates

[FCEO029 Customer Service Charter](#)

Notes

3.10 Portable and Attractive Assets

- Statutory context** Local Government (Financial Management) Regulations 1996 –
- r.17A(5) – assets to be excluded from asset register if fair value at date of acquisition is under \$5,000
 - r.17B – CEO to take steps to protect excluded portable and attractive assets

[Local Government \(Audit\) Regulations 1996 –](#)
[- r.17\(1\)\(b\) – CEO to review internal controls](#)
[- r.17\(2\) – review is to be undertaken at once every 3 financial years](#)

- Corporate context** Delegations Register –
- 3.3 – Disposing of property, and impounded, confiscated or uncollected goods
- Policy Manual –
- 3.1 – Purchasing
 - 3.11 – Significant Accounting Policies
 - 12.11 – Asset Management
- Executive Instruction
- 3.6 – Purchase of Telephones, Software/Hardware and Electronic Equipment

History Adopted 24 July 2019
[Amended 23 June 2021](#)

Policy Statement

1. Statement

Portable and attractive assets are to be recorded in a format approved by the CEO, in order to –

- a) be safeguarded against theft, fire and loss,
- b) enable the physical control of high risk, low value acquisitions,
- c) ensure that losses resulting from such items are minimised; and
- d) ensure that the Shire does not incur significant costs in terms of managing low risk, low value items.

2. Scope

This policy applies to all items –

- a) that are portable and attractive with an acquisition value less than the asset recognition threshold for non-current assets and where the item satisfies all of the following criteria –
 - i) portable – that is, the item can be easily moved between locations by one person; and
 - ii) attractive - by its nature (size, utility, marketability) is susceptible to theft or loss; and
 - iii) valued at, or within the Shire's portable and attractive asset recognition thresholds.
- b) items defined as a portable and attractive asset –
 - i) purchased by the Shire, irrespective of the funding source and
 - ii) includes items gifted or donated to the Shire.

3. Thresholds

- a) The threshold's for portable and attractive assets to be recorded are –

Category	Threshold ex GST
Information technology / electronic devices <ul style="list-style-type: none"> - cameras, video & audio equipment - mobile phones - laptop computer, tablets, printers etc - GPS devices - other items as determined by the CEO 	\$500 to less than \$5,000
General equipment and items <ul style="list-style-type: none"> - power tools, chainsaws etc - trade equipment - floating plant / loose tools - road counters / traffic classifiers - other items as determined by the CEO 	\$1,000 to less than \$5,000

b) All costs for portable and attractive items is to be expensed using the appropriate account as determined by the chart of accounts.

4. Assets \$5,000 ex GST and over

Assets having a fair value of \$5,000 ex GST or more at date of acquisition, are to be capitalised in accordance with Policy 12.11 Asset Management and relevant Significant Accounting Policies.

5. Exclusion

- a) Items valued at less than the approved portable and attractive asset thresholds are not considered portable and attractive assets and therefore should not be recorded.
- b) Items as determined by the CEO in Executive Instruction that are –
 - i) to be fixed to vehicles, buildings etc (eg: two way radios), or
 - ii) otherwise determined.

6. Recording

- a) To facilitate effective internal control over these items, each item will be individually registered and maintained in the approved format by the [Manager Corporate Services](#).
- b) Where possible, each item will be uniquely identified and an individual custodian who, due to their ability to directly exercise control over the item, will be responsible for the safe custody of the item.
- c) Purchases will be captured via the purchasing system and acquisition cost, acquisition date, description fields, serial number, item custodian and any other relevant details are to be recorded within the appropriate register.
- d) Portable and attractive items are removed from the register when they are disposed of (e.g. due to being obsolete, surplus or damaged beyond repair) or identified as lost or stolen.

Deleted: Manager Finance

7. Stocktake

- a) Each Executive Manager, in consultation with the [Manager Corporate Services](#), is responsible for ensuring that a stock take of all registered portable and attractive items within their jurisdiction is carried out on a regular basis, but at least every three years.
- b) In addition, all registered portable and attractive items will be subject to spot audits on a periodic basis by the Executive Manager Corporate and Community Services or their delegate, to ensure that adequate control over these items has been maintained.
- c) Audits may take the following form –
 - in conjunction with tag and testing
 - recognition of existence through regular servicing/maintenance schedules
 - include a condition rating

Deleted: Manager Finance

Deleted: may

- d) Outcomes of the stocktake will be reported to the EMCCS, highlighting those items identified as lost, stolen or unaccounted for in detail, and advised to the relevant Executive Manager and [Manager Corporate Services](#).

Deleted: Manager Finance

8. Reporting

A report will be produced at least every three years for each Executive Manager –

- a) outlining the staff who are noted as custodians of portable and attractive items,
- b) the last time the item was part of a stocktake and where applicable,
- c) the condition of the item.

9. Disposal of Portable and Attractive Items

Disposal of Portable and Attractive Items will be undertaken in accordance with Delegation 3.3 Disposing of property, and impounded, confiscated or uncollected goods.

10. Stocktake

A stocktake of portable and attractive items within a Department is to be undertaken –

(a) at the time fair value is being assessed for assets of that class.

(b) within 1 month of being directed to be undertaken by –

(i) CEO;

(ii) Executive Manager Corporate and Community Services for any area of Shire operations; or

(iii) Executive Manager for the relevant Department.

Procedures

Executive Instruction 3.6 – Purchase of Telephones, Software/Hardware and Electronic Equipment

Forms and Templates

None

– End of Policy

Notes

Shire of Narrogin Artwork Collection in Smartsheet link is here: [Shire of Narrogin Artwork Collection Register - Smartsheet.com](#)

Stocktake for the purposes of this policy requires that the asset/s be physically sighted and counted, and reconciled to the records held.

3.11 Significant Accounting Policies

Statutory context	Local Government Act 1995
	Local Government (Financial Management) Regulations 1996
	Australian Accounting Standards
Corporate context	Annual Budget
	Annual Financial Statements
History	Adopted 24 July 2019
	Amended 23 June 2021

Policy Statement

1. [The accounts of the Shire of Narrogin are to be kept in accordance with –](#)
 - a) [legislative requirements;](#)
 - b) [Australian Accounting Standards and the instructions of the Australian Accounting Standards Board,](#)
 - [and](#)
 - c) [as required by the auditor.](#)
2. [Significant Accounting Policies as used throughout the year in accordance with clause 1 are confirmed by the adoption of the Annual Statement by Council.](#)

Procedures

Monthly Financial Instructions – Assets

Forms and Templates

Asset Acquisition Blank 2018-19

Asset Disposal Blank 2018-19.

– End of Policy

Notes

Deleted: ¶
The following Policy Schedules is adopted, and forms part of this Statement – ¶
Sch. 3.11 – Significant Accounting Polices forming part of the Notes to the Annual Financial Report

Deleted: Policy Schedule needs detailed review and consideration annually in June to ensure consistency with advice from relevant persons, resulting from possible changes in legislation and accounting standards etc during the financial year.¶

3.12 COVID 19 Financial Hardship

Statutory context	Local Government Act 1995 Local Government (Financial Management) Regulations 1996 Local Government (COVID19 Response) Order 2020 (SL 2020/57)
Corporate context	Delegations Register – 3.6 – Sundry and rates debtors – recovery and agreements 3.7 – Write-off of sundry and rates debtors Executive Instructions – 3.4 – Debt recovery – Rates debtors 3.5 – Debt Recovery – Sundry debtors Strategic Community Plan 2017-27 – Objective 4 – Civic Leadership – Continually enhance the Shire’s organisational capacity to service the needs of a growing community’ Strategy 4.1.2 – Continue to enhance communication and transparency

History Adopted 28 July 2020

Policy Statement

1. Purpose
 - a) The Shire recognises the likelihood that COVID-19 will increase the occurrence of financial hardship and vulnerability in our community.
 - b) The purpose of this policy is to ensure that the Shire administration provides fair, equitable, consistent and dignified support to debtors suffering hardship, while treating all members of the community with respect and understanding at what is a difficult time.
 - c) This Policy will remain in place until such time as the COVID19 pandemic order is revoked.
2. Scope
 - a) This policy is intended to apply to all debtors experiencing financial hardship regardless of their status, be they a property owner, tenant, business owner, etc., and is applicable to –
 - i) outstanding rates and service charges as at the date of adoption of this Policy;
 - ii) rates and service charges levied for the 2020/21 financial year; and
 - iii) outstanding debts as at the date of adoption of this policy.
 - b) To avoid any doubt, to the extent of any incontinency existing during the duration of this Policy, it overrides the existing permanent Executive Instructions –
 - i) 3.4 Debt Recovery – Rates Debtors; and
 - ii) 3.5 Debt Recovery – Sundry Debtors.
 - c) This policy is to be interpreted as an extension and clarification of Delegations 3.6 and 3.7.
3. Definitions

Act means Local Government Act 1995.
financial hardship means where a change in a person’s circumstances results in them being unable to pay rates and service charges without affecting their ability to meet their basic living needs, or the basic living needs of their dependants.
debtor means a person or entity that is responsible for the payment of rates and service charges and other debts to the Shire.
4. Operation
 - a) Expectation
The Shire recognises that many ratepayers will and / or are already experiencing financial hardship due to the COVID-19 pandemic. The Shire respects and anticipates that –
 - i) The probability that additional financial difficulties will arise when rates and service charges and invoices are received by the community.

Deleted: ¶
Policy Schedule 3.11 – Significant Accounting Policies forming part of the Notes to the Annual Financial Report ¶
BASIS OF PREPARATION ¶
 The financial report comprises general purpose financial statements which have been prepared in accordance with Australian Accounting Standards (as they apply to local governments and not-for-profit entities) and Interpretations of the Australian Accounting Standards Board, and the *Local Government Act 1995* and accompanying regulations. ¶
 ¶
 The *Local Government (Financial Management) Regulations 1996* take precedence over Australian Accounting Standards. Regulation 16 prohibits a local government from recognising as assets Crown land that is a public thoroughfare, such as land under roads, and land not owned by but under the control or management of the local government, unless it is a golf course, showground, racecourse or recreational facility of State or regional significance. Consequently, some assets, including land under roads acquired on or after 1 July 2008, have not been recognised in this financial report. This is not in accordance with the requirements of *AASB 1051 Land Under Roads paragraph 15* and *AASB 116 Property, Plant and Equipment paragraph 7*. ¶
 ¶
 Accounting policies which have been adopted in the preparation of this financial report have been consistently applied unless stated otherwise. Except for cash flow and rate setting information, the report has been prepared on the accrual basis and is based on historical costs, modified, where applicable, by the measurement at fair value of selected non-current assets, financial assets and liabilities. ¶
 ¶
CRITICAL ACCOUNTING ESTIMATES ¶
 The preparation of a financial report in conformity with Australian Accounting Standards requires management to make judgements, estimates and assumptions that effect the application of policies and reported amounts of assets and liabilities, income and expenses. ¶
 ¶
 The estimates and associated assumptions are based on historical experience and various other factors that are believed to be reasonable under the circumstances; the results of which form the basis of making the judgements about carrying values of assets and liabilities that are not readily apparent from other sources. Actual results may differ from these estimates. ¶
 ¶
THE LOCAL GOVERNMENT REPORTING ENTITY ¶
 All funds through which the Shire controls resources to carry on its functions have been included in the financial statements forming part of this financial report. ¶
 ¶
 In the process of reporting on the local government as a single unit, all transactions and balances between those funds (for example, loans and transfers between funds) have been eliminated. ¶
 ¶
REVENUE AND EXPENSES ¶
 ¶
Grants, Donations and Other Contributions ¶
 Grants, donations and other contributions are recognised as revenues when the local government obtains control over the assets comprising the contributions. ¶
 ¶
 Where contributions recognised as revenues during the reporting period were obtained on the condition that they be expended in a particular manner or used over a particular period, and those conditions were undischarged as at the reporting date, the nature of and amounts pertaining to those undischarged conditions are disclosed in Note 23. That note also discloses the amount of contributions recognised as revenues in a previous reporting period which were obtained in respect of the local government’s operations. ¶
 ¶
CASH AND CASH EQUIVALENTS ¶
 ¶
 Cash and cash equivalents include cash on hand, cash at bank, deposits available on demand with banks and other short term highly liquid investments that are readily convertible to known amounts of cash and which are subject to an insignificant risk of changes in value. Bank overdrafts are reported as short term borrowings in current liabilities in the statement of financial position. ¶
 ¶
TRADE RECEIVABLES ¶
 ¶

- ii) The Shire will seek to support debtors and the community more generally in dealing with financial hardship and other challenges arising from the COVID-19 pandemic.
 - iii) The Shire will write to debtors at the time their account falls in arrears, to advise them of the terms of this policy and encourage eligible debtors to apply for hardship consideration.
 - iv) Where possible and appropriate, we will also provide contact information for a recognised financial counsellor and/or other relevant support services.
- b) Financial Hardship Criteria
- i) While evidence of hardship will be required, the Shire recognises that not all circumstances are alike. The Shire will take a flexible approach to a range of individual circumstances including, but not limited to, the following situations:
 - recent unemployment or under-employment
 - sickness or recovery from sickness
 - low income or loss of income
 - unanticipated circumstances such as caring for and supporting extended family.
 - ii) Debtors will be encouraged to provide any information about their individual circumstances that may be relevant for assessment. This may include demonstrating a capacity to make some payment/s and where possible, entering into a payment proposal. The Shire will consider all circumstances, applying the principles of fairness, integrity and confidentiality, whilst complying with statutory responsibilities.
- c) Payment Arrangements
- i) Payment arrangements will be of an agreed frequency and amount. These arrangements will consider the following –
 - whether a debtor has made genuine effort to meet debt, rate and service charge obligations in the past;
 - whether the payment arrangement will establish a known end date that is realistic and achievable.
 - ii) The debtor will be responsible for informing the Shire of any change in circumstances that may jeopardise the agreed payment schedule.
 - iii) In the case of severe financial hardship, an application may be referred to Council to consider waiving additional charges or interest (excluding the late payment interest applicable to the Emergency Services Levy).
- d) Interest Charges
- Interest charges will not be raised on a debtor that meets the financial hardship criteria and enters into a payment arrangement.
- e) Debt recovery
- i) The Shire will suspend its debt recovery processes while negotiating a suitable payment arrangement with a debtor. Where a debtor is unable to make payments in accordance with the agreed payment arrangement and the debtor makes an alternative payment arrangement with the Shire before defaulting on the 3rd due payment, the Shire will continue to suspend all debt recovery processes.
 - ii) Where a debtor has not reasonably adhered to the agreed payment plan, the Shire will, for any rates and service charge or debt that remains outstanding on 1 July 2021, offer the debtor one further opportunity to adhere to a payment arrangement that will clear the total debt by the end of the 2021/22 financial year.
 - iii) Rates and service charge or debts that remain outstanding at the end of the 2021/22 financial year, will be subject to the debt recovery procedures prescribed in the Act, Council Policy or Executive Instructions.
- f) Review
- When a debtor is aggrieved by a decision under this policy, the person may seek a review. The Review Officer is the Chief Executive Officer.
- g) Communication and Confidentiality
- i) The Shire will maintain confidential communications at all times and undertake to communication with a nominated support person or other third party at the debtors request.
 - ii) The Shire will advise debtors of this policy and its application, when communicating in any format (i.e., verbal or written) with a debtor with an outstanding debt, rate or service charge debt.

h) Implementation

The policy is to be implemented by the CEO, Executive Manager Corporate & Community Services (EMCCS) and agreements can be entered into under the authority of the CEO, EMCCS or Manager Corporate Services, in accordance with Delegations 3.6 and 3.7 and sub-delegation of power.

5. Termination of policy

This policy has no effect following 30 June 2022 or in accord with clause 1(c), if earlier.

Forms and Templates

FCCS017 Request for payment arrangement Form

– End of Policy

Notes

Ombudsman Western Australia publication: 'Local Government collection of overdue rates for people in situations of vulnerability: Good Practice Guidance'

3.13 Rating – Change in Predominant Use of Rural Land

Statutory context Local Government Act 1995 –
- s.6.26 to s.6.82
Local Government (Financial Management) Regulations 1996 –
- r.55 – Rate record, form of etc. (Act s.6.39(1))

Corporate context Delegation 3.5 – Rates Record, Extensions and Objections

History Adopted 28 July 2020

Policy Statement

Where there is evidence that there has been a change in the predominant use of land, resulting from either the subdivision or amalgamation of rural land, or development of that land, the Shire will:

1. Ensure that any rural property where the valuation method is Unimproved Value (UV) is accurately assessed in the determination of its predominant use as that of rural, or otherwise.
2. Properties where the size is twenty (20) hectares or less, with evidence of a residential dwelling situated on the parcel, and without evidence that it is being used contiguously with a larger parcel of land held by the same landowner, nor being used for a declarable source of income for taxation purposes, resulting from a rural use; will be classified as non-rural purpose and subject to a valuation of Gross Rental Value (GRV).
3. All properties that are zoned Special Rural, which include Rural Residential and Rural Smallholdings, shall be subject to a valuation of GRV.
4. Those properties found where the predominant use of the land is that of non-rural purposes will be referred to the Minister for Local Government. Adequate information will be provided so that a determination can be made on the method of valuation to be applied.
5. Where rural land is subdivided into smaller lots such as that of subsection (2), the Shire will, upon receipt of the Western Australian Planning Commission approval for subdivision of the affected land, apply to the Minister for Local Government for a change in valuation methodology from UV to GRV.
6. Subject to ministerial approval in subsection (4), the Shire is to apply the valuation method of GRV for rural land used predominantly for non-rural purposes.
7. All landowners affected by the change in the valuation method and rating shall be notified and advised of their right of appeal, prior to reporting to the minutes for Council.

– End of Policy

Notes

Rural purpose is defined as land which is used exclusively for farming activities such as cropping, grazing and/or similar intensive use of land for agricultural purposes.

3.14 Rating – Contiguous Land Use

Statutory context Local Government (Financial Management) Regulations 1996 –
- r.55 – Rate record, form of etc. (Act s.6.39(1))
Local Government (Financial Management) Regulations 1996 –
- r.56 – Rate notice, content of etc. (Act s.6.41)
Valuation of Land Act 1978
- Valuer General's Guide to Rating and Taxing Values (Version: Published February 2012)

Corporate context Delegation 3.5 – Rates Record, Extensions and Objections

History Adopted 22 September 2020
Amended 26 May 2021

Policy Statement

Contiguous rating, also known as group rating, is the rating of multiple land titles on one rates notice. This method can occur within the Shire, provided the following criteria is met on the land upon which this policy may apply.

1. Unimproved Value

Where the land valuation is Unimproved Value (UV), the following criteria shall be met for the eligibility of contiguous rating:

- 1.1. The land (lots or locations) is contiguous (share a common border) and in common ownership and;
- 1.2. The land is used and occupied as one holding; and
- 1.3. The common use and contiguity of the land is likely to continue into the future (eg the relevant portion(s) are not marketed for sale); and
- 1.4. The land parcels, although possibly separated by a road or waterway (such as a river, stream, creek etc.), would otherwise be adjoining.

The Council's policy position is that land outside of townsites utilised for genuine farming enterprise should be contiguously rated, to assist in minimising the cost of production, minimise the unplanned breakdown or disaggregation of farmland and to maximise the opportunities for that land to continue to be aggregated for productive agricultural pursuits and purposes.

2. Gross Rental Value

The Council's policy position is that land in townsites should not normally be contiguously rated, as to do so encourages the practice of holding land for speculation. This pushes prices up and inhibits the use of land designated for industrial, commercial or residential development being utilised for those purposes.

Where the basis of land valuation is GRV, contiguous rating is not permitted unless:

- 1.1. The land (lots or locations) is:
 - 1.1.1. contiguous (sharing a common border), and
 - 1.1.2. in common ownership, and
 - 1.1.3. clearly used, fenced, and occupied, and appears as one clear activity or business

and either or both of the following also applies:

- 1.2. Buildings have (due to a past error) been built across the lot boundaries, and/or
- 1.3. The adjoining land is part of an approved development or used as a tennis court or manicured garden.

Adjoining owners' vacant residential, rural residential or rural zoned land in a town site will generally not be supported for contiguous rating, unless extenuating circumstances prevail.

Definitions

A 'manicured garden' is "a garden that has been significantly developed and continues to be well maintained with, for example, infrastructure, reticulation, paths or fixed seating; is generally lawned or heavily planted with flowering plants or planted shrubs or trees; and clearly incorporated into the occupation of the adjoining lot used for residential purposes without fencing between the common holdings; and viewed from the streetscape as attractive and functioning and being enjoyed as one occupation across the boundary."

A 'Building' is a permanent fixed structure that is not capable of being easily demolished.

An 'approved development' is defined as being in accordance with a Development Application approved pursuant to the former Shire of Narrogin Town Planning Scheme No. 2 or former Town of Narrogin Town Planning Scheme No. 2.

If the required criteria are met, the Shire will write to Landgate (The Valuer General) to request the contiguous rating of the affected titles on behalf of the owner.

Where the Chief Executive Officer determines that land does not meet the criteria for contiguous rating, the landowner will be given a right of appeal to the Council.

– End of Policy

Notes

An example of contiguous rating on land rated UV is a farming property which comprise a number of lots/locations that are under common ownership and used contiguously as one large holding and farming operation.

Properties in a Townsite approved for contiguous rating will be recorded on the Property Assessment in the Rate Book and reviewed for continuing conformity with this Policy on at least a 5 yearly basis.

Section 4 - ORDER / PUBLIC SAFETY

No Council Policies applicable to this area of operations.

Section 5 - FIRE CONTROL

5.1 Bush Fire Brigades – Establishment

Statutory context Bush Fires Act 1954 –
- s.41 – establishment and maintenance of Brigades

Corporate context None

History Adopted 13 September 2016
Last reviewed 24 July 2019
[Last reviewed 7 June 2021](#)

Policy Statement

1. The following Council Policy Schedules are adopted, and form part of this Statement –
5.1 – Volunteer Bush Fire Brigades areas
2. In accordance with the Bush Fires Act section 41(1) the following Bush Fire Brigades are established, and have the area as per Council Policy Schedule 5.1 Bush Fire Brigade areas –
 - Boundain
 - Highbury East
 - Highbury South
 - Highbury West
 - Minigin
 - Narrogin Central
 - Narrogin South
 - Narrogin Valley
 - Nomans Lake
 - Ockley

– End of Policy

Notes

Brigades are not incorporated organisations.

Narrogin townsite is the responsibility of the Narrogin Fire and Emergency Services Unit, and is managed by Department of Fire and Emergency Services.

Policy Schedule 5.1 – Bush Fire Brigade areas

As at 1 March 2017

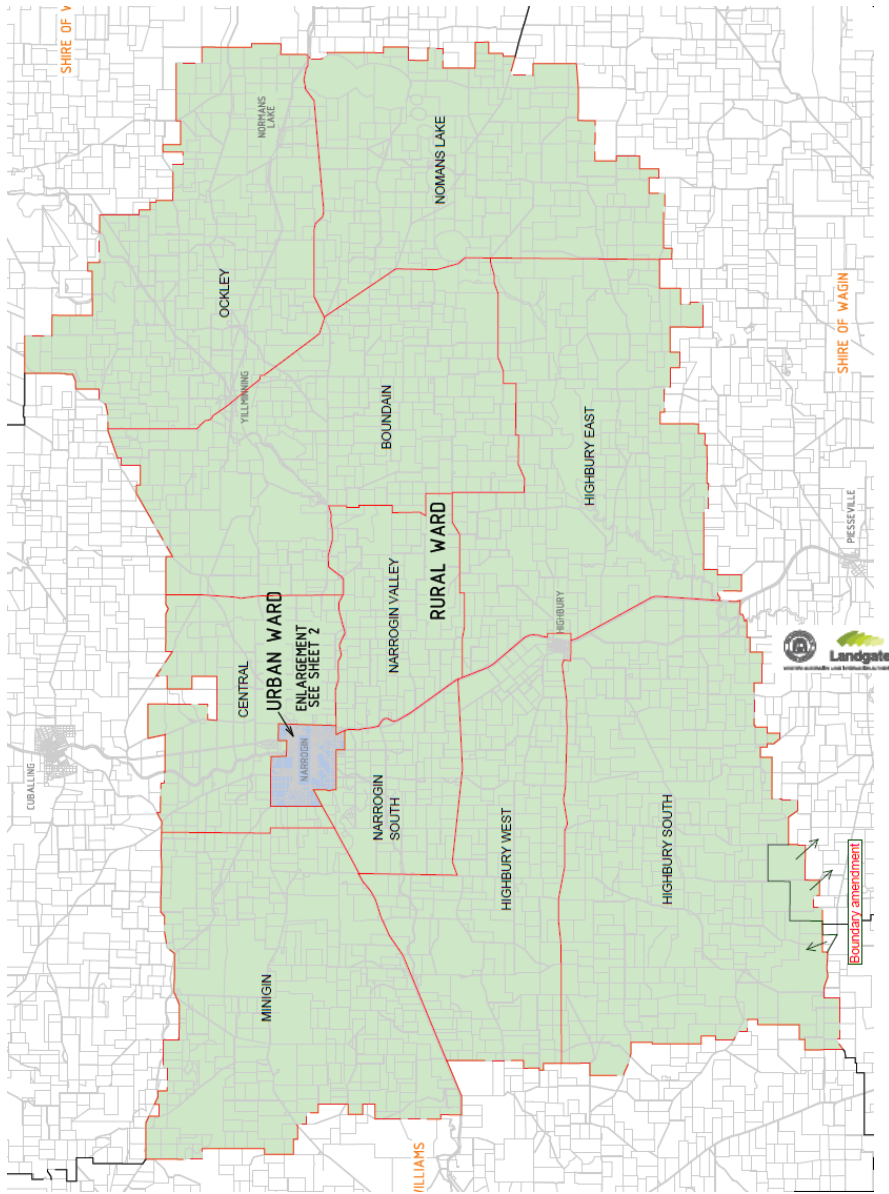

– End of Schedule

5.2 Bush Fire Brigades – Management

Statutory context	Bush Fires Act 1954 Occupational Safety and Health Act 1984 Shire of Narrogin Bush Fires Brigades Local Law 2017
Corporate context	Delegation 5.1 – Issue of burning permits – CEO Delegation 5.2 – Fire fighting – Emergency plant hire Delegation 5.4 – Prohibited and restricted burning periods – Variation
History	Adopted 26 April 2017 Last reviewed 24 July 2019 Amended 24 September 2020 <u>Amended 23 June 2021</u>

Deleted: (required by the Act, but not yet in force)¶

Policy Statement

1. Legislative context
 - a) Bush Fires Act –
The head of power for Council and FCOs to manage all fire related matters
 - b) Occupational Safety and Health Act –
In place since 1984, this Act is often ignored or overlooked –
 - Organisational responsibilities include –
 - o to carry appropriate insurance
 - o to provide training, PPE, resources
 - o to make certain vehicles are safe, roadworthy, fit for task and available for use
 - o to ensure all levels of bush fire brigade volunteers and staff members act lawfully and appropriately
 - Volunteer and employee obligations include –
 - o to act to ensure their own safety and welfare, and for those they are responsible for and are around them
 - o to use PPE provided
 - o to undertake appropriate training
2. Application
 - a) While this policy specifically applies to Volunteer FCOs, where relevant, it also applies to those appointed due to their position as a Shire employee.
 - b) This policy also applies to FCOs appointed to dual roles on the nomination of other Shires.
3. Appointment of Fire Control Officers
 - a) FCOs are appointed by Council or the CEO under delegated power, usually on the nomination of an FCO Meeting.
 - b) FCOs may also be appointed on the nomination of an adjoining Shire.
 - c) In accordance with the BFB Local Law, FCOs will be appointed by Council as the Captain and First Lieutenant of each Brigade, although their authority as FCO extends throughout the Shire.
4. Term of Office
The Chief Bush Fire Control Officer and Deputy Chief Bush Fire Control Officer are appointed for a three year term.
5. Fire Weather Committee

Deleted: by Council

Deleted: Subject to

- a) This Committee is not appointed by Council, but is formed by the Chief BFCO to advise on weather conditions
6. Allocation of WAERN radios
- a) Vehicles – each FCO
 - b) Base – each FCO, Fire Weather Committee members, Base Radio Operator (if not an FCO), Shire Office
 - c) Handhelds – Ranger, Narrogin Police, as arranged by CBFCO and CEO.
7. Training
- a) Required –
 - Fire Control Officers Course – FCOs to complete every 5 years [in accordance with the requirements of the Bush Fire Brigades Local Law 2016.](#)
 - b) Recommended –
 - Australian Interagency Incident Management System – CBFCO, DCBFCO, CEO, EMDRS, Ranger
 - Intro to Structural Firefighting / Structural Awareness – FCOs
 - Intro to Bush Fire Fighting – all volunteers
 - Fire Ground Plant Operations – selected Shire staff.
8. Fire Ground Plant Operations
- a) Shire staff are not to operate any Shire plant on the fire ground unless appropriate Fire Ground Plant Operations training is completed
 - b) Authorisation of staff to utilise Shire plant on the fire ground must be obtained prior to operation from:
 - CEO;
 - EMTRS; or
 - MO.

Deleted: (refer draft BFB Local Law)

– End of Policy

Notes

CBFCO	Chief Bush Fire Control Officer
CEO	Chief Executive Officer
DCBFCO	Deputy Chief Bush Fire Control Officer
EMDRS	Executive Manager Development & Regulatory Services
EMTRS	Executive Manager Technical & Rural Services
FCO	Fire Control Officer
MO	Manager Operations

5.3 Firebreaks and Fuel Hazard Reduction – Inspection & Prosecution

Statutory context	Bush Fires Act 1954 – - s.56(1) – duty of FCO to advise non-compliance Fire Breaks and Fire Hazard Reduction Notice
Corporate context	Delegation 3.6 – Sundry and Rate Debtors – Recovery and Agreements Policy 5.5 – FCO Duties
History	Adopted 26 April 2017 Last reviewed 24 July 2019 Last reviewed 7 June 2021

Policy Statement

1. Firebreaks must be installed and fuel hazard reduction measures taken each year by the date required by the Firebreaks and Fuel Hazard Reduction Notice.
2. The inspection of firebreaks is to commence not later than seven days after the required date.
3. The inspection is to be carried out by the Ranger or other person directed by the CEO, and preferably accompanied by an FCO.
4. In accordance with the Bush Fires Act s.56(1), FCO's are to report any firebreaks not in compliance to the CEO as soon as possible, for action.
5. The owner/occupier of a property found not to comply with requirements is to be sent a letter requiring compliance by a specified date not more than 10 days after inspection.
6. A second inspection of non-complying properties is to be carried out, after the specified date for compliance has elapsed.
7. Where a property remains non-compliant, the CEO is authorised without further notice, to –
 - a) issue an infringement notice, and
 - b) arrange for the carrying out of works so that the property complies, either using the Shire's own staff or contractors.
8. Where compliance has had to be arranged by the CEO, the full cost of achieving compliance, is to be recovered from the property owner either –
 - a) if completed by contractor – the cost invoiced by the contractor engaged, plus 10%, or
 - b) if completed by Shire staff and plant – at full private works rates.
9. Non-payment of an infringement notice or cost of achieving compliance is to be treated as a sundry debt, and appropriate cost recovery actions.

– End of Policy

Notes

- The Firebreaks and Fire Hazard Reduction Notice –
- must be published in the Government Gazette and local public notice given in order to be enforceable,
 - once published, has the effect of being a local law.

5.4 Harvest & Movement of Vehicles Bans

Statutory context Bush Fires Act 1954

- s.14B – Powers of authorised persons and police officers during authorised periods
- s.27 – Prohibition on use of tractors or engines except under certain conditions

Shire of Narrogin Firebreaks and Fuel Hazard Reduction Notice

Corporate context None

History

Adopted	26 April 2017
Amended	24 July 2019
Last reviewed	7 June 2021

Policy Statement

1. After taking advice from fire control officers as may be available or appropriate, the following persons may determine a Harvest and Movement of Vehicles Ban is to be imposed and to arrange notification (in order of authority) :
 - a) Chief Bush Fire Control Officer;
 - b) Deputy Chief Bush Fire Control Officer;
 - c) Chief Executive Officer;
 - d) Executive Manger Development and Regulatory Services.
2. Notification of Harvest and Movement of Vehicles Bans are to be notified to:
 - a) ABC Radio, and other radio stations broadcasting locally;
 - b) Department of Fire and Emergency Services, Department of Parks and Wildlife;
 - c) adjoining Shires;
 - d) message placed on the Shire of Narrogin Fire and Harvest Bans Information line (answering machine);
 - e) by SMS broadcast.
3. On notification of a Harvest and Movement of Vehicles ban:
 - a) Shire plant on road reserves, in gravel pits etc outside the Narrogin townsite is to cease that activity.
 - o This restriction does not apply to legal use of vehicles on constructed public roads.
 - b) Shire crews undertaking activities that could be considered "hot work" (chainsaw, brush cutter, slashing etc) are to cease that activity.
 - o This restriction does not apply where –
 - the activity is within the Narrogin or Highbury townsite, and
 - is on green grass/vegetation or surrounded by a clear area complying with the Fire Break and Hazard Reduction Notice.
 - o This exemption may be over-ridden by a Total Fire Ban, which prohibits any hot work in the open air, that may be issued by Department of Fire and Emergency Services.

– End of Policy

Notes

5.5 FCO Duties

Statutory context Bush Fires Act 1954
Occupational Safety and Health Act 1984

Shire of Narrogin Bush Fires Brigades Local Law 2017

Corporate context Delegation 5.4 – Prohibited and restricted burning periods – Variation

History Adopted 26 April 2017
Last reviewed 24 July 2019
[Last reviewed 7 June 2021](#)

Policy Statement

1. Fighting fires is inherently dangerous. Matters within the control of each FCO, volunteer and person that add to that risk include –
 - a) absence of or inadequate management at the fire site (incident control, team leader)
 - b) failure to report to the person managing the fire, to follow their instructions
 - c) inappropriate attire
2. In the event of an emergency, an FCO is to ensure the safety of firefighters –
 - a) Incident Control is to be established appropriate to the circumstances,
 - b) Any FCO or person in charge of a fire, or any other person authorised to do so, may order away from the fire, any person not wearing adequate and appropriate attire, e.g.: inappropriate footwear, synthetic fabrics, shorts, short-sleeved shirt etc
3. In the event of an emergency, the FCO / Incident Control should provide relevant details to the Shire Office as able, in order to –
 - a) arrange support as needed,
 - b) respond to phone calls and enquiries from the community and others,
 - c) issue SMS broadcast if necessary.

4. Fire reports

The appropriate FCO is to submit a written report on the forms supplied by the Shire, of any uncontrolled fires in their area.

– End of Policy

Notes

Refer Bush Fires Act s.39, s.56

5.6 Fire Fighting – Emergency plant hire

Statutory context	Local Government Act 1995 – - s.6.8(1)(c) – authorisation of unbudgeted expenditure in an emergency Bush Fires Act 1954 – - s.38(3)(4)(5) – appointed BFCO's may exercise specific authorities given to them Occupational Safety and Health Act 1984 Shire of Narrogin Bush Fires Brigades Local Law 2017
Corporate context	Delegation 5.4 – Prohibited and restricted burning periods – Variation
History	Former Delegation 12 July 2016 Adopted as Policy _____ Last reviewed 7 June 2021

Policy Statement

1. Approval is given to commit expenditure for the private hire of plant and equipment necessary for the efficient fighting and control of fires.
2. Person who may give approval for private hire of plant and equipment are –
 - a) Chief Executive Officer
 - b) Executive Manager Corporate & Community Services
 - c) Executive Manager Development & Regulatory Services
 - d) Executive Manager Technical & Rural Services
 - e) Manager Operations
 - f) Rangers

– End of Policy

Notes

Any approval to be sought is an administrative function for expenditure purposes only, and does not extend to giving of operational instructions.

Where possible, the person is to seek advice from the senior FCO at the fire, and approval from the CEO or an Executive Manager. However, since this policy will only be used in emergency situations, it is acknowledged that this may not be possible.

Adequate resources to fight a fire, for the safety of fire fighters, and for the protection of life and property have the highest priority, and are not to be unnecessarily jeopardised by delay.

Section 6 - ENVIRONMENTAL HEALTH / FOOD

6.1 Itinerant Vendor Policy

Statutory context	Local Government Act 1995 Public Places and Local Government Property Local Law 2016 Food Act 2008 Food Regulations 2009 Food Safety Standards 3.2.2 and 3.2.3 Council's Planning Scheme current at that time – currently the Former Town of Narrogin Town Planning Scheme No. 2 and the Former Shire of Narrogin Town Planning Scheme No. 2
Corporate context	Shire of Narrogin Strategic Community Plan.
History	Adopted 28 April 2020 Last reviewed 7 June 2021

Policy Statement

The Shire of Narrogin:

- Encourages the use of parks and reserves for itinerant vending activities as a means of enhancing community activity that flows from the activation of community public spaces;
- Encourages business proprietors to activate parks and reserves with appropriate itinerant vending activities;
- Recognises that granted rights over the relevant public space does not exclude the general public from using that public space;
- Supports Itinerant Vendors who consider the needs of all users of the area, including consumers and pedestrians; and
- Supports Itinerant Vendors selling food who practice safe food handling in accordance with the *Food Act 2008*, *Food Regulations 2009* and *Food Safety Standards*.

Policy objectives

To allow outdoor unique and high quality itinerant vending activities in a manner that improves access, usage, quality and image of the Shire's public areas whilst managing the competing needs and interests of the public, pedestrians, consumers and local business proprietors.

Policy scope

This policy applies to all itinerant vending businesses that wish to operate within the Shire's local government area. Where it is proposed to sell food a minimum setback is required from an existing fixed food premises. This policy does not apply to events approved by the Shire.

Summary

An Itinerant Vending Licence (Licence) is required prior to operating as an itinerant vendor. The Licence is only valid in the park or reserve nominated on the licence. The parks and reserves where itinerant vending is permitted are listed in Schedule One. Planning approval may be required, from the Shire, should itinerant vending be proposed on land not mentioned in Schedule One. Licences can be either day specific (one off) or an annual licence. Licences are obtained from the Shire's Environmental Health Services, Development and Regulatory Services Department.

Making an application

To be able to operate as an Itinerant Vendor the applicant is to:

1. Submit a current Public Liability insurance certificate of cover. For further information refer to the Public Risk Management section below;
2. Ensure they are compliant with local laws and this policy's objectives and requirements;
3. For a food business, be a registered food business within the State of Western Australia and hold a current Food Business Registration Certificate;
4. Pay the application Fees (as per the Shire of Narrogin's Fees and Charges schedule as current at that time) – determined annually by Council;
5. Nominate the park or reserve which they wish to trade and indicate the approximate location within that park or reserve, trading dates and times; and
6. Submit a completed application form, together with applicable fees, if any, to the Shire of Narrogin, 89 Earl Street, Narrogin WA 6312 or by email enquiries@narrogin.wa.gov.au.

Licences

Licences will only be issued to applicants after a written application has been made. Completed applications will be assessed by the Shire's Environmental Health Officer. All applications will be assessed against the Assessment Criteria.

Location and siting

Trading by Itinerant Vendors is only permitted in the parks and reserves listed in Schedule One.

General location and siting requirements include:

- Itinerant vendor, if a mobile food van, is not to be placed within 100 metres of a fixed or permanent Food Business;
- Itinerant vending is not to impede pedestrian access including prams, wheelchair and mobility scooter access;
- Itinerant Vending, where food is sold is not permitted within the Central Business District (CBD) zone; and
- Itinerant vending will not be supported for activities where vehicle size or layout may compromise public access, circulation, safety, or other park or street activities. Should concerns be raised by local businesses or the community regarding the operation or location of an Itinerant Vendor, the Shire may require the Itinerant Vendor to relocate.

Maintenance and cleaning

The Itinerant Vendor is required to comply with all maintenance and cleaning aspects of the entire operation, including the conditions of the Licence. The following requirements also apply:

1. The Itinerant Vendor's Vehicles and fixtures must be kept in a safe, well maintained and road worthy condition at all times;
2. The trading area (including food preparation areas) must be regularly cleaned during all hours of operation presenting a well-cared for image and free of refuse and litter;
3. No waste or litter may be disposed of into the Shire's refuse bins;
4. Licence holders must provide bins for their own and their patrons use and remove such waste to a licenced waste management facility under the control of the Shire at the Licence Holders cost; and
5. The Licence Holder is responsible for the care, appearance, maintenance and operation of their activity area and the effect on other park, reserve and street activities. It must be understood that the trading zone remains a public space. This means that operators and patrons do not have exclusive occupancy of this area.

Assessment criteria and licence conditions:

The Licence Holder is advised that:

1. Permanent fixtures and elements are not permitted;
2. Trading times are to be between 7:00am and 9:00pm, 7 days per week;
3. Following trade, the Itinerant Vendor's vehicle and all related temporary fixtures must be removed from the site;
4. The Licence Holder must have a vehicle whose presentation contributes to the character and amenity of the area;
5. Only vehicles with a maximum weight of up to 2 tonnes will be permitted on a park or reserve;
6. Any fixtures relating to the itinerant vending (for example: signs, umbrellas, waste bins etc) should be sturdy and windproof, made of quality materials and be well designed and constructed to be safe to use, without sharp edges or other features likely to cause injury;
7. The Licence Holder must not obstruct, cover, remove, relocate or modify trees, public art, benches, refuse bins or other Shire owned infrastructure as a result of itinerant vending activities;
8. The Licence Holder must not sell alcohol or tobacco products at any time;
9. The Licence Holder must ensure all advertising is fixed to the vehicle and does not encroach onto the public space;
10. The Licence Holder is restricted to trade ONLY in the park or reserve nominated in the Licence – refer to Schedule One of this policy for permitted locations;
11. Fixtures must not be placed anywhere by the Licence Holder where they present a barrier and/or danger to pedestrians crossing the street or kerbside usage by motorists;
12. The Licence Holder and the Licence Holder's vehicle and/or fixtures must not be positioned where they would block access to service covers and existing services;
13. All items belonging to the Licence Holder positioned within their trading zone are the Licence Holders responsibility;
14. The Licence Holder must vacate the site when trading has ceased for the day;
15. The Licence Holder is responsible for their own security and the security of their site area;
16. The Licence Holder's vehicle and/or fixtures are to be self-contained and self-sufficient and must not require external power, gas, sewer or water connections;
17. The Licence Holder is permitted to play background music provided the noise levels comply with the Assigned Levels prescribed in the *Environmental Protection (Noise) Regulations 1997*;
18. If operating generators, the Licence Holder must ensure that the noise level of the generator complies with the Assigned Levels in the *Environmental Protection (Noise) Regulations 1997*;
19. Should justified complaints be received regarding noise, including amplified music, generators or other operational noise from itinerant vending activities, the Shire reserves the right to prohibit the emission of noise from that site;
20. The Licence Holder and the Licence Holder's vehicle and fixtures are to be sited at least 15 metres away from a road or footpath construction zone during the period of the project;
21. The Licence Holder is strongly encouraged to provide seating for patrons in trading areas, where there is sufficient space;
22. When a community event, approved by the Shire, is being held within the trading area (for example community fairs and concerts), any Itinerant Vending licences allocated to that park or reserve will be rendered null and void for the duration of that event;
23. Licences will only will only be granted for a period of up to 12 months. The licence is to be renewed annually with all licences expiring on 30 June of each year; and
24. The Licence Holder must at all times comply with the Act and the local laws.

Conditions for itinerant food vendors

Itinerant Vendors who intend to sell food are only permitted to trade within the Shire if the following requirements are met:

1. The Itinerant Vendor must hold a valid Shire of Narrogin Itinerant Vending Licence;
2. The itinerant Vendor must hold a current *Food Act 2008* Food Business Registration Certificate from a Western Australian Local Government;
3. Mobile food vans are not to be placed within 100 metres of a fixed or permanent Food Business or within the town of Narrogin CBD;
4. Licence holders selling food are to ensure that all food products are kept under lock and key at all times when the vending unit is not attended (for example: for bathroom breaks); and
5. Itinerant vehicles and marques must be self-sufficient and not require an external power, water, sewer or gas connection.

Public Risk Management

1. Licence Holders must take out and keep current public and product liability insurance policy in the names of the Shire of Narrogin and the Licence Holder, indemnifying the local government in respect of any injury to any person or any damage to any property which may occur in connection with the use of the local government property by the Itinerant Vendor. The indemnity insurance policy must be for the amount of at least TEN MILLION DOLLARS (\$10,000,000) and must cover injury, loss or damage to persons or property arising out of the activity carried out under this Licence or the granting of this Licence by the Shire. A lesser amount of public and product liability insurance might be accepted by the Shire but this decision will be subject to a risk assessment process. A Certificate of Currency for the policy must accompany the application or renewal of an 'Itinerant Vending Licence';
2. Safety measures may be required in trading zones and will be assessed on a case-by-case basis by the Shire. If public safety cannot be reasonably addressed, licences will not be issued. It is the Licence Holders responsibility to ensure that the public remain safe in their licenced area;
3. BBQs, grills and heat sources must be protected to prevent public access and accidental burning and fire risk. External BBQs, grills and other heat sources using a naked flame will be banned from use during fire bans;
4. Licence holders are required to comply with all work place Safety and Health legislation as well as Public Health and food safety aspects of the entire operation as required by the legislation; and
5. The Licence Holder assumes responsibility for any liability issues which arise from their itinerant vending activities.

Compliance

Failure to comply with this policy may result in the cancelation of the Itinerant Vending Licence or an existing licence not being renewed, as provided in the *Public Places and Local Government Property Local Law 2016*.

Objection and review rights

Division 1 of Part 9 of the Act applies to a decision under the local law and this policy in respect of the grant, renewal, transfer, amendment, suspension or cancellation of a licence or consent

Forms and Templates

Itinerant Vendor Application (See <https://www.narrogin.wa.gov.au/documents/forms.>)

– End of Policy

SCHEDULE ONE

Parks and reserves within the Shire of Narrogin where Itinerant Vending is permitted with an Itinerant Vending Licence:

Gnarojin Park – south of the Skate Park area;

Memorial Park – adjacent to the Court House;

Clayton Road – carpark adjacent to the entrance to the Race and Pace track entrance;

Clayton Road – carpark adjacent to the YMCA Regional Leisure Centre; and

Lions Park – in the car park area off Leake Street.

Section 7 - COMMUNITY SERVICES

7.1 Narrogin Regional Homecare – Management

Statutory context Local Government Act 1995
[Quality and Safety Commission Aged Care Standards](#)

Corporate context None

History Adopted 26 April 2017
Last reviewed 24 July 2019
[Amended 23 June 2021](#)

Policy Statement

1. Narrogin Regional Homecare is to maintain a detailed Procedures Manual compliant with the requirements of the [Health Department of WA and Aged Care Standards](#).
2. Compliance with the Manual is a condition of engagement as an employee or volunteer of Narrogin Home Care.
3. The Manual is to be reviewed by the Manager [Client and Community Care Services](#) annually or as required in accordance with any legislative changes, and proposed amendments submitted to the CEO for approval.
4. The attached Schedule 7.1 Narrogin Regional Homecare lists the matters to be included covered by the Manual, but is not limited to these specific items.

– End of Policy

Notes

Deleted: Department of Health and Ageing Community Care Common Standards

Deleted: Homecare

Policy Schedule 7.1 – Narrogin Regional Homecare Procedures Manual

Section –

- [1. 01 Consumer Dignity and Choice](#)
- [2. 02 Assessment and Planning](#)
- [3. 03 Personal Care and Clinical Care](#)
- [4. 04 Services and Supports of daily living](#)
- [5. 05 Service Environment](#)
- [6. 06 Feedback and Complaints](#)
- [7. 07 Human Resources](#)
- [8. 08 Organisational Governance](#)

– End of Schedule

Deleted: <#>Corporate Governance¶
Regulatory Compliance¶
Information Management Systems¶
Community Understanding and Engagement ¶
Continuous Improvement¶
Risk Management¶
Human Resource Management¶
Physical Resources¶
Service Access¶
Assessment¶
Support Planning and Delivery¶
Client Reassessment ¶
Client Referral¶
Information Provision¶
Privacy and Confidentiality¶
Complaints and Client Feedback ¶
Advocacy¶
Independence¶
Food Safety Practices¶
Vehicle Best Practices¶
Emergency and Natural Disasters¶

Section 8 - PERSONNEL

Applying to all matters in relation to personnel and employment –

Local Government Act 1995 –

s.5.41 Functions of CEO

The CEO's functions are to –

-
- (d) manage the day to day operations of the local government; and
-
- (g) be responsible for the employment, management supervision, direction and dismissal of other employees (subject to section 5.37(2) in relation to senior employees); and
-

s.5.103 Model code of conduct for council members, committee members and candidates

(1) Regulations must prescribe a model code of conduct for council members, committee members and candidates

Local Government (Model Code of Conduct) Regulations 2021 –

r.3 Model code of conduct

Sch 1 Model code of conduct

cl.19 Prohibition against involvement in administration

cl.20 Relationship with local government employees

(2) A council member or candidate must not –

- (a) direct or attempt to direct a local government employee to do or not to do anything in their capacity as a local government employee; or
- (b) attempt to influence, by means of a threat or the promise of a reward, the conduct of a local government employee in their capacity as a local government employee; or
- (c) act in an abusive or threatening manner towards a local government employee.

(4) If a council member or candidate, in their capacity as a council member or candidate, is attending a council or committee meeting or other organised event (for example, a briefing or workshop), the council member or candidate must not orally, in writing or by any other means –

- (a) make a statement that a local government employee is incompetent or dishonest; or
- (b) use an offensive or objectionable expression when referring to a local government employee.

Policy 1.1 – Code of Conduct for council members, committee members and candidates

For clarification regarding appointment, management and direction of employees –

Employee class	Council involvement	Elected member / Committee involvement	CEO involvement
CEO	<u>Required.</u> May delegate selection and interview to a Committee. Appointment must be by Council resolution.	<u>Permitted</u> – to interview and recommend to Council. <u>Prohibited</u> – to appoint, manage or direct.	As directed by Council, usually limited to process, research and reporting on an applicant.

Deleted: Local Government (Rules of Conduct) Regulations 2007 –¶

r.10 Relations with local government employees¶

(1) A person who is a council member must not –¶
 (a) direct or attempt to direct a person who is a local government employee to do or not to do anything in the person's capacity as a local government employee; or¶
 (b) attempt to influence, by means of a threat or the promise of a reward, the conduct of a person who is a local government employee in the person's capacity as a local government employee.¶
¶

Designated staff LG Act s.3.57	<p><u>Required</u> – to consent to appointment or dismissal.</p> <p><u>Permitted</u> – Interview & recommendation can be done by CEO alone or with elected member input.</p> <p><u>Prohibited</u> – management or direction.</p>	<p><u>Permitted</u> – to interview and recommend to Council.</p> <p><u>Prohibited</u> – to appoint, manage or direct.</p>	<p><u>Required</u> to initiate / consent to appointment or dismissal.</p> <p><u>Statutory function</u> – to manage and direct.</p>
EHO	<p><u>If designated senior employee</u> – as above, otherwise – <u>In all cases</u> – qualification must comply with Public Health Act 2016 s.17.</p>		
Other staff (non-designated)	<p><u>Prohibited</u> – Involvement in appointment, management or direction.</p>	<p><u>Prohibited</u> – involvement in appointment, management or direction.</p>	<p><u>Statutory function</u> – to appoint, manage, direct etc.</p>

8.1 Disciplinary Action

WALGA Workplace Relations, November 2016 – amended

Statutory context Fair Work Act 2009 (Commonwealth)
Fair Work Regulations 2009 (Commonwealth)
Corruption and Crime Commission Act 2003 (WA)
Public Interest Disclosure Act 2003 (WA)

Corporate context Policy 8.3 – Employee Performance and Development
Policy 8.4 – Grievance

Executive Instruction 8.1 – Disciplinary Action

[Code of Conduct – Employees](#)

History Adopted 26 April 2017
Last reviewed 24 July 2019
[Last reviewed 7 June 2021](#)

Policy Statement

1. The CEO is to prepare and maintain a detailed Executive Instruction regarding this matter, which is to include but is not limited to –
 - a) general disciplinary principles,
 - b) serious misconduct,
 - c) other disciplinary action, and
 - d) reporting obligations.

– End of Policy

Notes

Deleted: Policy 1.1 – Code of Conduct

8.2 Discrimination, Harassment and Bullying

WALGA Workplace Relations, November 2016 – amended

Statutory context Occupational Safety and Health Act 1984 (WA)
Occupational Safety and Health Regulations 1996 (WA)
Equal Opportunity Act 1984
Fair Work Act 2009

Corporate context Policy 8.4 – Grievance
Policy 8.21 – Equal Employment Opportunity

[Code of Conduct – Employees](#)

Executive Instructions –
- 8.1 – Disciplinary Action
- 8.2 – Discrimination, Harassment and Bullying

History Adopted 26 April 2017
Last reviewed 24 July 2019
[Last reviewed 7 June 2021](#)

Policy Statement

1. The CEO is to prepare and maintain a detailed Executive Instruction regarding this matter, which is to include but is not limited to –
 - a) application of legislation to the Shire, relevant employees, volunteers and contractors,
 - b) unlawful discrimination,
 - c) harassment,
 - d) sexual harassment,
 - e) bullying, and
 - f) management action.

– End of Policy

Notes

8.3 Employee Performance and Development

WALGA Workplace Relations, November 2016 – amended

Statutory context Local Government Act 1995

Corporate context Policy 8.1 – Disciplinary Action

[Code of Conduct – Employees](#)

Executive Instruction 8.3 – Employee Performance and Development

History

Adopted	26 April 2017
Last reviewed	24 July 2019
Last reviewed	7 June 2021

Policy Statement

1. The CEO is to prepare and maintain a detailed Executive Instruction regarding this matter, which is to include but is not limited to –
 - a) employees to which the Executive Instruction applies
 - b) commitment to development of employee skills and capabilities,
 - c) induction of employees to cover performance management and development,
 - d) performance reviews covering types of review, purpose and conduct,
 - e) other mechanisms for feedback to employees
 - f) training and development
 - g) underperformance.

– End of Policy

Notes

8.4 Grievance

WALGA Workplace Relations, November 2016 – amended

Statutory context Local Government Act 1995 –
-
-

Corporate context 
Policy 8.1 – Disciplinary Policy
Policy 8.2 – Discrimination, Harassment, & Bullying Policy
Policy 8.21 – Equal Employment Opportunity

[Code of Conduct – Employees](#)

Executive Instruction 8.4 – Grievance

Deleted: Policy 1.1 – Code of Conduct

History
Adopted 26 April 2017
Last reviewed 24 July 2019
[Last reviewed 7 June 2021](#)

Policy Statement

1. The CEO is to prepare and maintain a detailed Executive Instruction regarding this matter, which is to include but is not limited to –
 - a) employees to which the Executive Instruction applies,
 - b) making of a complaint,
 - c) principles for resolution of a complaint,
 - d) outcomes of complaints,
 - e) vexations or malicious complaints,
 - f) prohibition on victimisation of a complainant.
2. Any grievances lodged against the CEO are to be dealt with by the Shire President under this policy.

– End of Policy

Notes

8.5 Higher Duties

WALGA Workplace Relations, November 2016 – amended

Statutory context	Local Government Industry Award 2010
Corporate context	Policy 2.5 – Acting / Relieving Staff Authority Policy 8.13 – Recruitment and Selection Code of Conduct – Employees Executive Instruction 8.5 – Higher Duties
History	Adopted 26 April 2017 Last reviewed 24 July 2019 Last reviewed 7 June 2021

Policy Statement

1. The CEO is to prepare and maintain a detailed Executive Instruction regarding this matter, which is to include but is not limited to –
 - a) employees to which the Executive Instruction applies,
 - b) circumstances in which higher duties will apply.
2. The Executive Instruction is to apply to all employees, excluding the CEO and Executive Manager level positions, who are required to act in a position of higher classification than that which the employee occupies or who is assigned responsibilities or duties which warrant the payment of a higher duty allowance.

– End of Policy

Notes

8.6 Leave – Award Entitlements

WALGA Workplace Relations, November 2016 – amended

Statutory context	National Employment Standards Local Government Industry Award 2010
Corporate context	Executive Instruction 8.6 – Leave – Award Entitlements
History	Adopted 26 April 2017 Last reviewed 24 July 2019 Last reviewed 7 June 2021

Policy Statement

1. The CEO is to prepare and maintain a detailed Executive Instruction regarding this matter, which is to include but is not limited to –
 - a) acknowledgement of the priority of the Local Government Industry Award 2010 and the National Employment Standards,
 - b) annual leave processes, including –
 - i) maximum accrual of annual leave to be 8 weeks,
 - ii) arrangements to require employee to take excessive annual leave,
 - iii) annual leave over an organisation or specific crew close down
 - iv) annual leave in advance
 - c) personal / carer's leave, including –
 - i) requirements to notify supervisor or manager,
 - ii) circumstances in which evidence of illness or injury etc, may be required,
 - d) unpaid leave
 - e) consequences for breach of the Executive Instruction.

– End of Policy

Notes

8.7 Leave – Community Service

WALGA Workplace Relations, November 2016 – amended

Statutory context Fair Work Act 2009 (Commonwealth)
Juries Act 1957

Corporate context [Code of Conduct – Employees](#)
[Executive Instruction 8.7 – Leave – Community Service](#)

History Adopted 26 April 2017
Last reviewed 24 July 2019
[Last reviewed 7 June 2021](#)

Policy Statement

1. The CEO is to prepare and maintain a detailed Executive Instruction regarding this matter, which is to include but is not limited to –
 - a) acknowledgement of the priority of the provisions of the Fair Work Act 2009 (Commonwealth),
 - b) acknowledgement of priority of the provisions of the Juries Act 1957,
 - c) application to all employees of the Shire,
 - d) obligation on employee to notify of membership of any relevant organisation that may necessitate leave,
 - e) priority area for consideration of leave is within the Shire, but the CEO to have discretion in appropriate circumstances,
 - f) in exceptional circumstances, CEO to have discretion to approve paid leave.

2. The definitions to apply are –

voluntary activity is where an employee engages in a voluntary activity, and the following criteria are met

-
- a) the activity is either of –
 - a voluntary community activity, or
 - a voluntary emergency management activity
- b) the employee engages in the activity on a voluntary basis;
- c) either –
 - i) the employee was requested by or on behalf of the body to engage in the activity; or
 - ii) no such request was made, but it would be reasonable to expect that, if the circumstances had permitted the making of such a request, it is likely that such a request would have been made.

voluntary community activity is where an employee engages in a voluntary emergency management activity if all the following criteria are met –

- a) the employee engages in an activity that involves the community generally or a significant portion of the community;
- b) the employee is a member of, or has a member-like association with, a recognised community organisation.

voluntary emergency management activities is where an employee engages in a voluntary emergency management activity if all the following criteria are met –

- a) the employee engages in an activity that involves dealing with an emergency or natural disaster;
- b) the employee is a member of, or has a member-like association with, a recognised emergency management body; and

– End of Policy –

Notes

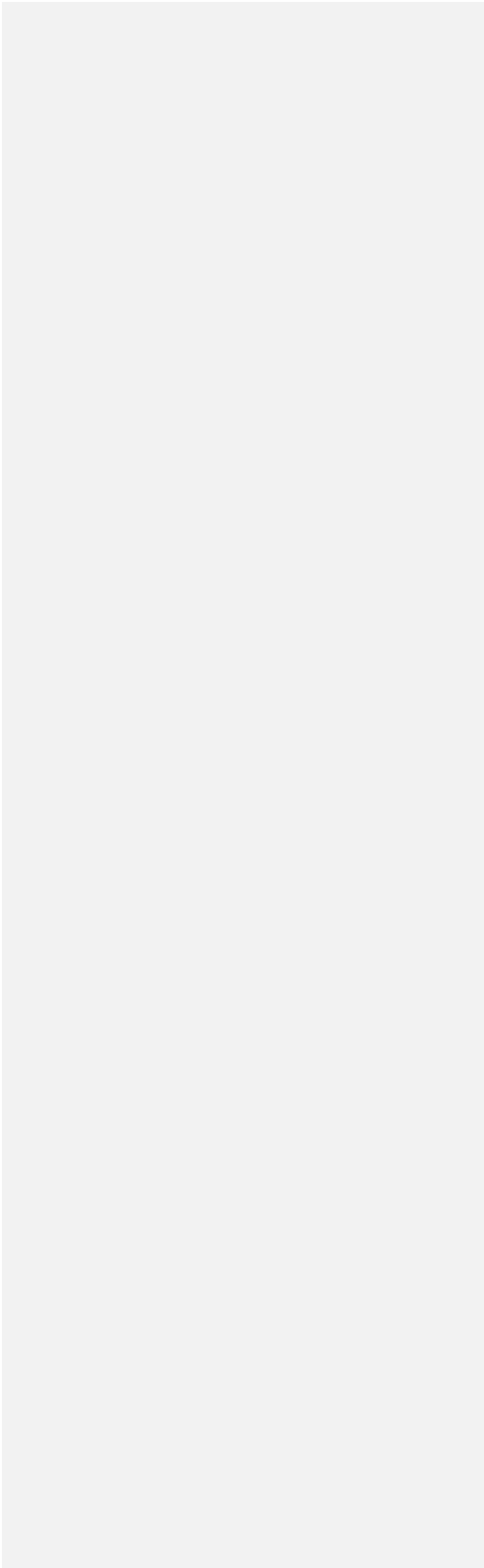

8.8 Leave – Long Service

WALGA Workplace Relations, November 2016 – amended

Statutory context Local Government (Long Service Leave) Regulations

Corporate context Executive Instruction 8.8 – Leave – Long Service

History

Adopted	26 April 2017
Last reviewed	24 July 2019
Last reviewed	7 June 2021

Policy Statement

1. The CEO is to prepare and maintain a detailed Executive Instruction regarding this matter, which is to include but is not limited to –
 - a) acknowledgement of the priority of the Local Government (Long Service Leave) Regulations,
 - b) long serve leave processes –
 - i) maximum accrual of annual leave to be 8 weeks,
 - ii) arrangements to require employee to take excessive annual leave,
 - iii) annual leave over an organisation or specific crew close down,
 - iv) annual leave in advance,
 - c) taking of pro-rata long service leave prior to due date in exceptional circumstances and subject to completion of a minimum 7 years' service in local government,
 - d) long service leave taken later than 6 months after due date at the employee's request, not to be paid at a rate higher than that specified by the Regulations,
 - e) long service leave taken later than 6 months after due date at the CEO's request, to be paid at the rate applicable when taking the long service leave,
 - f) long service leave may not be deferred by the employee for more than 2 years, without the specific written approval of the CEO, which may only be given in exceptional circumstances.

– End of Policy

Notes

8.9 Probationary Periods of Employment

WALGA Workplace Relations, November 2016 – amended

Statutory context Local Government Act 1995

Corporate context Policy 8.10 – Recruitment and Selection

[Code of Conduct – Employees](#)

Executive Instruction 8.9 – Probationary Periods of Employment

History

Adopted	26 April 2017
Last reviewed	24 July 2019
Last reviewed	7 June 2021

Policy Statement

1. The CEO is to prepare and maintain a detailed Executive Instruction regarding this matter, which is to include but is not limited to –
 - a) acknowledgement of the priority of the Local Government (Long Service Leave) Regulations,
 - b) disclosure requirements for probationary period,
 - c) completion or extension of probationary period,
 - d) termination during a probationary period.

– End of Policy

Notes

8.10 Recruitment and Selection

WALGA Workplace Relations, November 2016 – amended

Statutory context Local Government Act 1995
Local Government (Administration) Regulations 1996
Equal Opportunity Act 1984
Occupational Safety and Health Act 1984

Corporate context Policy 8.2 – Discrimination, Harassment and Bullying Policy
Policy 8.4 – Grievance Policy
Policy 8.9 – Probationary Periods of Employment Policy
Policy 8.21 – Equal Employment Opportunity Policy

[Code of Conduct – Employees](#)

Executive Instruction-

- 8.5 – Higher Duties
- 8.10 – Recruitment and Selection

History

Adopted	26 April 2017
Last reviewed	24 July 2019
Last reviewed	7 June 2021

Policy Statement

1. The CEO is to prepare and maintain a detailed Executive Instruction regarding this matter, which is to include but is not limited to –
 - a) acknowledgement of the priority of the Local Government Act and Regulations requirements for section on merit, CEO and Designated senior staff recruitment,
 - b) acknowledgement of the principles of the Equal Opportunity Act,
 - c) procedural requirements to review requirement, commence, manage, and document the recruitment and selection processes,
 - d) filling of positions disclosed in the annual Budget to be an authorised action where the position,
 - e) filling of positions not disclosed in the annual Budget to be only on authority of CEO,
 - f) application of probationary periods to all positions with tenure greater than 6 months,
 - g) internal candidate preference where experience and potential indicate, for retention of corporate knowledge and development of clear career paths for staff,
2. The CEO and senior staff designated in accordance with the Local Government Act have separate or additional requirements, but unless inconsistent with legislative requirements, processes are to conform to this Executive Instruction.

– End of Policy

Notes

8.11 Rostered Days Off

WALGA Workplace Relations, November 2016 – amended

Statutory context Local Government Act 1995

Corporate context Executive Instruction 8.11 – Rostered Days Off

[Code of Conduct – Employees](#)

History

Adopted	26 April 2017
Last reviewed	24 July 2019
Last reviewed	7 June 2021

Policy Statement

1. The CEO is to prepare and maintain a detailed Executive Instruction regarding this matter, which is to include but is not limited to –
 - a) outside workers – on the basis of a 9 day fortnight,
 - b) inside staff – on the basis of a 19 day 4 week period'
 - c) accrual principles while on leave or public holidays,
 - d) accumulation of RDOs may be permitted by the relevant Executive Manager, but are not to exceed a maximum accrual of 5 days.

– End of Policy

Notes

8.12 Secondary Employment

WALGA Workplace Relations, November 2016 – amended

Statutory context Local Government Act 1995

Corporate context

Policy 8.1 – Disciplinary Action

[Code of Conduct – Employees](#)

Executive Instruction 8.12 – Secondary Employment

History

Adopted	26 April 2017
Last reviewed	24 July 2019
Last reviewed	7 June 2021

Deleted: Policy 1.1 – Code of Conduct

Policy Statement

1. The CEO is to prepare and maintain a detailed Executive Instruction regarding this matter, which is to include but is not limited to –
 - a) acknowledging the priority of the Local Government Act,
 - b) secondary employment to include substantial commitments to community organisations,
 - c) ensuring no conflict of interest with Shire concerns including –
 - i) use of Shire resources both physical and electronic, work time,
 - ii) potential for increased load on other staff
 - iii) community perception and preservation of the Shire's reputation,
 - d) employee responsibilities
 - e) CEO responsibilities.
2. Notwithstanding the limitations, there is to be a general encouragement for employees to participate in community activities.

– End of Policy

Notes

8.13 Training, Study and Education

WALGA Workplace Relations, November 2016 – amended

Statutory context	Local Government Act 1995 Building Regulations 2012 Food Act 2008 Occupational Safety and Health Act 1984 Public Health Act 2016
Corporate context	Policy 8.3 – Employee Performance and Development Policy 8.6 – Leave – Award Entitlements Policy 8.15 – Use of Fleet Vehicles – Work and Private Use Policy 8.18 – Use of Private Vehicles – Work Purposes

[Code of Conduct – Employees](#)

Executive Instruction 8.13 – Training, Study and Education

History	Adopted	26 April 2017
	Amended	24 July 2019
	Last reviewed	7 June 2021

Policy Statement

1. The CEO is to prepare and maintain a detailed Executive Instruction regarding this matter, which is to include but is not limited to –
 - a) mandatory qualification requirements for specific positions, in particular environmental health, food and building matters,
 - b) mandatory training requirements, in particular for plant operation and OSH,
 - c) professional development training directly associated with the employee's position,
 - d) professional development not related to the employee's position but potential benefit to the Shire,
 - e) circumstances in which expenses and type of expenses may be met in full or in part,
 - f) provision for an allowance to be claimed by employees making private arrangements for accommodation etc for any training related to (a), (b) or (c) above,
 - g) travel arrangements,
 - h) professional association membership
2. Permitted rates for daily accommodation and breakfast and dinner, if not included in the training/conference cost are –
 - a) those in accordance with the Australia Taxation Office Reasonable Travel Allowances Determination applicable to Perth (excluding incidentals), as issued for each financial year,
 - b) to reimbursed or authorised through purchasing procedures, and
 - c) not an allowance paid to the employee.
3. Where an employee has privately arranged accommodation, an allowance of 30% of the accommodation rate only, will be paid to the employee upon claim, and other reimbursements remain applicable.
4. Nothing in this policy prevents the CEO from approving accommodation at an expense greater than that provided in clause 2 if considered appropriate if the accommodation is at or near the conference or training venue, and other relevant matters are taken into account such as transport costs and time, employee safety and security after hours etc.

– End of Policy

Notes

- Clause 2 – Australian Taxation Office Determination
Reasonable Travel Allowances
<https://atotaxrates.info/allowances/ato-reasonable-travel-allowances/>

8.14 Uniforms, PPE and Personal Presentation

WALGA Workplace Relations, November 2016 – amended

Statutory context Occupational Safety and Health Act 1984

Corporate context Policy 8.1 – Disciplinary Action

[Code of Conduct – Employees](#)

Executive Instruction 8.12 – Uniforms, PPE and Personal Presentation

History

Adopted	26 April 2017
Amended	24 July 2019
Last reviewed	7 June 2021

Policy Statement

1. The CEO is to prepare and maintain a detailed Executive Instruction regarding this matter, which is to include but is not limited to –
 - a) indoor employees –
 - i) standard of dress if not wearing uniform,
 - ii) uniform allowance, whether private purchase or through corporate supplier,
 - iii) wearing and use of PPE is mandatory for relevant tasks
 - b) outdoor employees –
 - i) wearing and use of PPE is mandatory at all times
 - c) PPE and Clothing to be provided by the Shire,
 - d) conditions of use of PPE and uniforms,
 - e) wearing of PPE or clothing displaying the Shire logo out of work hours – inappropriate behaviour reflecting badly on the Shire may result in disciplinary action.
2. Uniform allowance for indoor employees, following completion of probation period –
 - full time employee - \$350 per year
 - part time employee - \$200 per year

– End of Policy

Notes

8.15 Use of Fleet Vehicles – Work and Private Usage

WALGA Workplace Relations, November 2016 – amended

Statutory context Occupational Safety and Health Act 1984

Corporate context Policy 8.1 – Disciplinary Action
Policy 8.17 – Workplace Surveillance

[Code of Conduct – Employees](#)

Executive Instructions –

- 8.13 – Training, Study and Education
- 8.15 – Use of Fleet Vehicles – Work and Private Usage

History

Adopted	26 April 2017
Last reviewed	24 July 2019
Last reviewed	7 June 2021

Policy Statement

1. The CEO is to prepare and maintain a detailed Executive Instruction regarding this matter, which is to include but is not limited to –
 - a) subject to any contractual arrangement with the employee,
 - b) principles of obtaining a vehicle,
 - c) arrangements for vehicle when employee takes leave,
 - d) CEO scope of authority and responsibility,
 - e) if deemed appropriate, CEO may require FBT expense be recovered from employee,
 - f) maintenance, responsibilities and requirements for vehicle – employee and Shire,
 - g) use of a fleet vehicle displaying the Shire logo or easily identified as a Shire vehicle out of work hours – inappropriate behaviour reflecting badly on the Shire may result in disciplinary action.
 - h) garaging of vehicle,
 - i) consequences for breach of the Executive Instruction.

– End of Policy

Notes

8.16 Use of Private Vehicles – Work Purposes

Statutory context Occupational Safety and Health Act 1984

Corporate context [Code of Conduct – Employees](#)

Executive Instructions –

- 8.1 – Disciplinary Action
- 8.13 – Training, Study and Education
- 8.16 – Use of Private Vehicles – Work Purposes

History

Adopted	26 April 2017
Last reviewed	24 July 2019
Last reviewed	7 June 2021

Policy Statement

1. The CEO is to prepare and maintain a detailed Executive Instruction regarding this matter, which is to include but is not limited to –
 - a) to be applied where approval is given to use a private vehicle for work purposes,
 - b) preference is for use of a fleet vehicle for all work purposes, but it is recognised that this is not always possible or appropriate,
 - c) procedure for approval to use a private vehicle, requirements and standards,
 - d) obligations of employee and Shire,
 - e) private vehicle not permitted to be used to transport Homecare clients,

– End of Policy

Notes

8.17 Workplace Surveillance

WALGA Workplace Relations, June 2016

Statutory context Surveillance Devices Act 1998

Corporate context

Policy 8.1 – Disciplinary

[Code of Conduct – Employees](#)

Executive Instruction 8.17 – Workplace Surveillance

History

Adopted	26 April 2017
Last reviewed	24 July 2019
Last reviewed	7 June 2021

Deleted: Policy 1.1 – Code of Conduct

Policy Statement

1. The CEO is to prepare and maintain a detailed Executive Instruction regarding this matter, which is to include but is not limited to –
 - a) acknowledgement that the purpose workplace surveillance is –
 - i) to ensure a safe environment for employees,
 - ii) after hours security for protection of assets and equipment,
 - iii) is not intended for surveillance of employees.
 - b) approved and prohibited placement of surveillance devices,
 - c) employees permitted to access images and recordings are –
 - i) CEO,
 - ii) Executive Managers,
 - iii) Information Technology Officer, under instruction
 - d) confidentiality of images and recordings,
 - e) consequences for breach of the Executive Instruction.

– End of Policy

Notes

Placement and use of surveillance cameras should also have regard to –
www.dpc.wa.gov.au/GuidelinesAndPolicies/PremiersCirculars/Lists/Circular/Attachments/237/2009_05%20Registration%20of%20CCTV%20Systems.pdf

8.18 Salary Sacrifice

Statutory context Australian Taxation Office –
- Goods and Services Tax – legislation, rulings and guidelines
- Fringe Benefits Tax – legislation, rulings and guidelines
- Superannuation – legislation, limits

Corporate context Executive Instruction 8.17 – Salary Sacrifice

History Adopted 26 April 2017
Last reviewed 24 July 2019
[Last reviewed 7 June 2021](#)

Policy Statement

1. The CEO is to prepare and maintain a detailed Executive Instruction regarding this matter, which is to include but is not limited to –
 - a) compliance with all requirements of the Australian Taxation Office,
 - b) being cost neutral to the Shire,
 - c) limits on amount that may be salary sacrificed, duration and purposes.

– End of Policy

Notes

8.19 Employees – Recognition of Service (Gratuity)

WALGA Workplace Relations, November 2016 – amended

Statutory context Local Government Act 1995 –
- s.5.50 – Payments to employees in addition to Award or contract

Local Government (Administration) Regulations 1996,
- specifically regulation 19A

Corporate context None

History Adopted 26 April 2017
Amended 24 July 2019
[Last reviewed 7 June 2021](#)

Policy Statement

1. Application

An employee who has been dismissed by the Shire for any reason other than redundancy, will not be eligible to receive any payment under this policy.

Long serving employees may be recognised within the parameters set by section 5.50 of the Local Government Act 1995 and the associated Regulations.

An employee, whose employment is finishing, may be paid to a gratuity payment when their employment is ceasing due to –

- a) Resignation (not as a result of any performance management or investigation being conducted or pending/potential disciplinary action by the Shire);
- b) Retirement; or
- c) Redundancy.

2. Gratuity

The CEO in consultation with the relevant Executive Manager, may –

- a) provide a gratuity to a qualifying employee in the form of a gift card or voucher from a local business within the Shire,
- b) exercise their discretion to provide money instead of a gift card or voucher.

3. Prescribed Amounts for Gratuity Payments

Gratuity payments should be calculated based on the following prescribed amounts –

- a) Continuous service less than 2 years – to the value of \$30 per year of service
- b) Continuous service greater than 2 years – to the value of \$50 per year of service
maximum payment of \$1,000

4. Exceeding prescribed amounts

In some circumstances, Council may consider it appropriate to make a payment greater than that specified by this policy. In which case local public notice is required to be given in relation to the proposed gratuity in accordance with the Local Government Act s.5.50 (2), and is not to exceed the amounts as set in the Local Government Administration Regulations 1996, specifically regulation 19A.

5. Determining Service

For the purpose of this policy, continuous service shall be deemed to include –

- a) any period of absence from duty on annual leave, long service leave, paid compassionate leave,

accrued paid personal leave and public holidays;

- b) any period of authorised paid absence from duty necessitated by sickness of or injury to the employee up to a maximum of three months in each calendar year, but not including leave without pay or parental leave; or
- c) any period of absence that has been supported by an approved workers compensation claim up to a maximum absence of 12 months.

For the purpose of this policy, continuous service shall exclude –

- d) any period of unauthorised absence from duty unless the CEO determines otherwise;
- e) any period of unpaid leave unless the CEO determines otherwise; or
- f) any period of absence from duty on parental leave unless the CEO determines otherwise.

6. Financial Liability for Taxation

The employee has full responsibility for any taxation payable on a gratuity payment.

– End of Policy

Notes

Statutory requirements –

- a) This Policy must be published on the Shire's website.**
- b) Recognition in excess of Policy may be made only if local public notice is given prior to payment being made.**

Advertised on 22 August 2019 (Narrogin Observer)

Notes – (to be removed when no longer applicable) –

The Shire acknowledges that at the time the policy was introduced –

- a) employees may be entitled to payments in addition to this policy as a result of accrued unused long service leave benefits, redundancy payments or notice periods as prescribed by, legislation or a relevant industrial instrument. The Shire has considered these provisions when setting the prescribed amount of any gratuity payment in this policy.
- b) the financial implications to the Shire were understood and that these financial implications had been investigated based on the workforce position current at that time.

8.20 Employee Superannuation

WALGA Workplace Relations, November 2016 – amended

Statutory context Superannuation Guarantee (Administration) Act 1992

Deleted: Contribution

Corporate context None

History

Adopted	26 April 2017
Amended	24 July 2019
Amended	23 June 2021

Policy Statement

1. Application

This Policy applies to all employees whether the full-time, part-time or casual.

2. Superannuation Benefit

Employees will have freedom of choice over the complying fund that their Superannuation Guarantee [Charge](#) (SGC) are paid into.

Deleted: Contributions

The superannuation default fund shall be the WA Super.

Employees may elect to contribute additional superannuation, either as a deduction (after tax) or as salary sacrifice (before tax).

The Shire will match the additional contribution to a maximum of 15.0% of salary, which includes the SGC component, that is – SGC component plus matching component not to exceed 15.0%.

- It should be noted that as the SGC component increases, the threshold for maximum matching contribution by the Shire will decrease.

Employees can voluntarily contribute more than the threshold but will not receive a further contribution from the Shire.

The additional contribution and the voluntary contribution can be deposited in to the employee's fund of choice.

3. Variation to This Policy

This policy may be cancelled or varied from time to time. All employees will be notified of any variation to this policy.

– End of Policy

Notes

8.21 Equal Employment Opportunity

WALGA Workplace Relations, November 2016 – amended

Statutory context WA Equal Opportunity Act 1984
Equal Opportunity Act 1986
Racial Discrimination Act 1975
Sex Discrimination Act 1984
Disability Discrimination Act 1992

Corporate context Policy 8.2 – Discrimination, Harassment and Bullying
Policy 8.4 – Grievance
Policy 8.10 – Recruitment and Selection
Policy 8.13 – Training, Study and Education

[Code of Conduct – Employees](#)

Executive Instructions –
- 8.2 – Discrimination, Harassment and Bullying
- 8.4 – Grievance
- 8.10 – Recruitment and Selection

History Adopted 26 April 2017
Last reviewed 24 July 2019
[Last reviewed 7 June 2021](#)

Policy Statement

1. [Introduction](#)

The Shire is committed to equal opportunity and diversity and promotes a work environment that is free from discrimination and harassment, and where individuals are treated with fairness, respect, equality and dignity.

This involves the improvement in the skills and competency levels of employees to provide equal access to further employment or career path progression. The Shire acknowledges and celebrates diversity and commits to continuing to actively and flexibly seek to appoint and accommodate the unique needs of many different employees.

2. [Application](#)

[This policy is to](#) apply to employees, potential employees, volunteers and contractors/consultants.

Deleted: adopted that

3. [Environment](#)

The Shire recognises that when conflict, discrimination and harassment occurs in the workplace, job satisfaction, morale and productivity suffers. A healthy and safe work environment free from unnecessary discrimination, harassment and bullying is the a primary objective of the Shire.

4. [Diversity](#)

The Shire appreciates the value inherent in a diverse workforce. Diversity may result from a range of factors; origin, age, gender, race, cultural heritage, lifestyle, education, physical ability, appearance, language or other factors.

5. [Awareness](#)

Upon appointment all employees are to be given a full copy of this Policy and ensure this Policy is easily accessible electronically and in other forms as requested.

6. Monitoring

Employment related practices are to be periodically reviewed in accordance with this Statement, with particular consideration of practices and policies.

– End of Policy

Notes

Section 9 - OCCUPATIONAL SAFETY & HEALTH

9.1 Occupational Safety & Health Policy – Employees, Volunteers, Contractors, Visitors

Statutory context Occupational Safety and Health Act 1984

Corporate context

Policy 8.1 – Disciplinary Action
Policy 8.4 – Grievance
Policy 9.4 – Workplace Visitors – Management

[Code of Conduct – Employees](#)

Executive Instructions –

- 9.1 – Occupational Safety & Health – Employees and Contractors

OSH – Manuals, Requirements, Standards and Procedures
OSH – Contractors Handbook

History

Adopted	26 April 2017
Reviewed	24 July 2019
Reviewed	28 October 2020
Adopted	24 November 2020
Last reviewed	7 June 2021

Deleted: Policy 1.1 – Code of Conduct

Policy Statement

1. The Shire of Narrogin will provide a safe and healthy work environment, so far as practicable, for:
 - a) the community,
 - b) employees,
 - c) volunteers,
 - d) contractors, and
 - e) visitors.
2. The Shire is committed to providing safe and healthy working conditions, which are aimed at the prevention of work related injuries and ill health. Consistent with this, the Shire will:
 - a) Provide and maintain a safe work environment by the identification and elimination of OSH hazards where possible, or reducing associated risk level to as low as is reasonably practicable, where hazards cannot be completely eliminated;
 - b) Strive for continuous improvement in Occupational Safety and Health performance utilising best practice procedures and taking into account evolving knowledge and technology;
 - c) Comply with all applicable legislation and requirements;
 - d) Establish, implement and maintain an Occupational Health and Safety Management System; including measurable objectives and targets aimed at elimination of work related injury and illness;
 - e) Ensure that all employees, including contractors and volunteers, are fully informed of potential hazards and associated risk control measures, including through a process of training, instruction, information sharing and supervision as applicable;
 - f) Communicate and consult with employees and their representatives, including contractors and volunteers, so as to ensure that everyone within the workplace is offered the opportunity to participate in the ongoing development of a safer and healthier workplace; and
 - g) Ensure that all employees, including contractors and volunteers, are fully aware of their responsibility to take reasonable care to safeguard their own health and safety at work and to avoid adversely affecting the health or safety of others through any act or omission at work and report

hazards, accidents, incidents and near misses to their supervisor.

3. Copies of this Policy shall be made available to all employees, volunteers, contractors and visitors, and displayed within the workplace.

– End of Policy –

Notes

Refer –

1. OSH – Manuals, Requirements, Standards and Procedures
2. OSH – Contractors Handbook

9.2 Occupational Safety & Health – Executive Instructions

Statutory context	Occupational Safety and Health Act 1984
Corporate context	OSH – Manuals, Requirements, Standards and Procedures OSH – Contractors Handbook
History	Adopted 26 April 2017 Last reviewed 24 July 2019 Last reviewed 7 June 2021

Policy Statement

1. The CEO is to prepare and maintain a detailed Executive Instructions regarding this matter, which is to include but is not limited to –
 - a) acknowledgement of the priority of the Occupational Safety & Health Act 1984,
 - b) the establishment and operation of employee based OSH Committee in accordance with the Act,
 - c) requiring the development, maintenance and review of OSH manuals, requirements, standards, procedures, guidelines etc
 - d) requiring the development, maintenance and review of OSH Handbook for Contractors etc
 - e) consequences for breach of the Executive Instruction.

– End of Policy

Notes

9.3 Drugs and Alcohol

WALGA Workplace Relations, November 2016

Statutory context Occupational Safety and Health Act 1984

Corporate context ▼

Policy 8.1 – Disciplinary
Grievance Policy
Grievance Procedure
Policy

[Code of Conduct – Employees](#)

Deleted: Policy 1.1 – Code of Conduct

History

Adopted	26 April 2017
Last reviewed	24 July 2019
Amended	7 June 2021

Policy Statement

1. Introduction

This policy is designed to eliminate the risks inherent in the use or abuse of drugs alcohol or other substances and to provide a safe and productive workplace for employees.

The Shire is committed to ensuring all employees take reasonable care not to endanger the safety of themselves or others (including customers) in the workplace. Alcohol and other drug usage becomes an occupational safety and health issue if a worker's ability to exercise judgment, coordination, motor control, concentration and alertness at the workplace is impaired.

2. Application

For the purpose of this policy –

- the term “employee” shall extend to cover contractors as per the Occupational Safety and Health Act 1984, volunteers and any person performing work for or with the Shire in any capacity,
- the workplace is defined as any place in which work is carried out while engaged by the Shire.

Employees must report to their employer any situation where they genuinely believe that an employee may be affected by alcohol and/or other drugs.

3. Responsibility

Under the Occupational Safety and Health Act 1984, workers must take reasonable care of their own safety and health and not endanger the safety and health of others at the workplace. The consumption of alcohol and/or drugs while at work is unacceptable (the hazard extends to being adversely effected, possibly as a result of the night before in addition to consumption as work), except in relation to any authorised and responsible use of alcohol at workplace social functions.

All employees are expected to comply with the [Code of Conduct for Employees](#) at all times. They should carry out their duties in a professional, responsible and conscientious manner and refrain from any conduct (including alcohol abuse or substance misuse) which could adversely affect their personal work performance or the safety and well-being of others.

Deleted: Shire's

Employees are required to present themselves for work and remain, while at work, capable of performing their work duties safely. An employee who is under the influence of alcohol and/or drugs at the workplace, or is impaired, may face disciplinary action including possible termination of employment.

4. Drug Use in a Shire workplace

Employees who buy, take, or sell drugs in any Shire workplace, may be found to have engaged in serious misconduct. Such behaviour may result in disciplinary action up to and including dismissal.

5. Prescribed and Over the Counter Medications

The Employee must follow the instructions in respect of prescribed or over the counter medications. If the medication affects their ability to perform a task they must advise their supervisor or manager. Employees taking prescribed or over the counter medication must not commence duties if their doctor or pharmacist indicates that it would not be safe to do so.

The categories of drugs and substances prohibited by the Shire are outlined as per the Australian Standard AS 4308 for drugs of abuse.

6. Consumption of Alcohol on the Premises

Except in situations where the Shire holds or hosts a function within the district and alcohol is provided, employees must not bring in and/or consume alcohol in the workplace. With the approval of the CEO or Executive Manager an employee may be approved to drink alcohol at a work related function.

7. Responsibilities

The Shire considers that the use of alcohol or other drugs is primarily a health issue for individual employees, however, where an employee's performance or conduct affects their health and safety, and/or others in the workplace, the Shire is committed to appropriately managing the issue.

A likely outcome of any breach of this policy will be disciplinary action (up to and including termination of employment), however the Shire may also manage the issue by –

- Providing appropriate education and training to employees;
- Providing professional counselling and support where needed.

8. Managers' Responsibilities – Consumption of Alcohol at Work Sponsored Functions

Team managers shall –

- a) encourage their staff to make alternative arrangements for transport to and from the function;
- b) ensure that the following is made available: - Low alcohol beer, soft drinks and water - Beverages: tea, coffee and food;
- c) if the manager believes a person may be over the Blood Alcohol Content (BAC) 0.05 limit, assist the person with safe transport home (including contacting a family member or arranging a taxi); and
- d) if the manager has to leave the function early, appoint a delegate to oversee the rest of the function.

9. Drug/Alcohol Treatment Programs

Where an employee acknowledges that they have an alcohol or drug problem and are receiving help and treatment, the Shire will provide assistance to the employee –

- a) the Shire will allow an employee to access any accrued personal or annual leave, or leave without pay by agreement of the CEO, while they are undergoing treatment, and;
- b) the Shire will take steps to return an employee to their employment position after completion of the treatment program, if practicable in the circumstances.

Where an employee acknowledges that they have an alcohol or drug problem and are receiving help and treatment, the line manager or members of senior management, will review the full circumstances and agree on a course of action to be taken. This may include redeployment to suitable alternative employment, or possible termination from employment if the employee is unable to safely carry out the requirements of their role.

10. Pre-Employment Medical Tests

As part of the recruitment selection process, preferred candidates for employment positions may be required to attend a medical assessment which includes drug and alcohol testing. Failure to provide a negative test result may result in their application for employment being unsuccessful.

11. Random Testing

Random testing may also be conducted. Random testing may utilise a variety of methods for randomly selecting names such as software, lottery of selection through coloured marbles in a bag drawn by each employee. All staff on site must participate in the random selection.

12. Identification of Impairment & Testing

If the Shire has reasonable grounds to believe that an employee is affected by drugs and/or alcohol it will take steps to address the issue.

Reasonable grounds may include (but are not limited to), where an employee's coordination appears affected, has red or bloodshot eyes or dilated pupils, smells of alcohol, acts contrary to their normal behaviour, or otherwise appears to be affected by drugs and/or alcohol.

Testing may be carried out as a result of all incidents (including, but not limited to near miss, injury, property damage, and personal altercations).

If the Shire suspects that an employee is under the influence of drugs and/or alcohol it may pursue any or all of the following actions –

- direct an employee to attend a medical practitioner and submit to a medical assessment to determine whether the employee is fit to safely perform their duties;
- require that an employee undergo drug and alcohol testing administered by a Shire authorised testing provider (such as Pathwest) at the direction of the Shire;
- direct an employee to go home.

A medical assessment may include a drug and/or alcohol test. Testing shall be conducted in accordance with the Australian Standard AS/NZS 4308:2008 – Procedures for specimen collection and the detection and quantitation of drugs of abuse in urine.

In circumstances where an employee indicates the consumption of prescription or pharmacy drugs, the Shire may request further information from the medical practitioner conducting the assessment about the effects and proper usage of the prescription or pharmacy drugs being taken. The Shire may direct the employee to go home following the medical assessment until it can be established that they are fit to undertake their duties.

If an employee refuses to attend a medical examination or refuses to submit to an alcohol or drug test, the employee will be immediately directed to go home. Refusal to attend a medical assessment or refusal to go home constitutes a breach of this policy and may result in disciplinary action being taken against the employee up to and including the termination of employment.

The following steps are to be taken where an employee who has submitted to a medical assessment returns a positive test result for alcohol and/or drugs –

- The employee tested and the CEO will be informed of the result;
- A disciplinary discussion will take place in accordance with the disciplinary policies and procedures of the Shire.

An employee who returns a positive test will be in breach of this policy. A breach of this policy may result in disciplinary action being taken against the employee up to an including the termination of employment.

13. Testing in the event of an accident/incident

The Shire, at the discretion of the CEO or Executive Manager may require an employee to undertake a drug

and alcohol test, as described above, in the event of an accident or incident where there is a risk to health and safety.

14. Education, Training & Awareness

The Shire may provide education and training to all employees at the workplace about the effects of alcohol and other drugs and their risks to safety and health. Line managers may be given training so that they may identify situations where an employee is potentially misusing alcohol or drugs.

Employees who recognise that they have a drink or drug problem, or that they are at risk of developing one, are encouraged to come forward so that they can be assisted to get the appropriate help. Contacts at outside agencies where help can be obtained will be made readily available to all employees via the Shire's noticeboards.

The Shire engages the services of an external Employee Assistance Provider who can provide the organisation's people with free and confidential counselling.

15. Testing Provider

Drug and alcohol testing may be undertaken by Pathwest Laboratories, Narrogin or another provider if required.

16. Consequences of Breaching this Policy

An employee engaged by the Shire who breaches the provisions of this policy may face disciplinary action including possible termination of employment.

17. Variation to This Policy

This policy may be cancelled or varied from time to time. All employees will be notified of any variation to this policy.

– End of Policy –

Notes

9.4 Health and Wellbeing

WALGA Workplace Relations, November 2016 – amended

Statutory context	None	
Corporate context	None	
History	Adopted	26 April 2017
	Amended	24 July 2019
	Last reviewed	7 June 2021

Policy Statement

1. Introduction

The Shire encourages the health and wellbeing of our employees at work and promotes employee work life balance so our employees are able to fulfil work and lifestyle responsibilities efficiently and effectively.

The purpose of this policy is to ensure that staff have the opportunity to access health and wellbeing initiatives and choices in the workplace.

2. Application

This policy applies to all permanent full time or part time employees of the Shire.

3. Wellbeing Program

LGIS Municipal Workcare Scheme has developed a preferred supplier arrangement, and it is through this that the Shire offers employees access to health services.

The Shire is provided with a range of health services such as –

- a) Health Assessments
- b) Skin Cancer Screenings
- c) Flu Vaccinations
- d) Health Seminars/ Workshops
- e) Ergonomic Assessments
- f) Manual Task Training

Periodically throughout the year, health and well-being matters will be promoted and made available to employees. As the services are dependent on funding, limited spaces may be available however every effort will be made to provide these services to those interested in participating.

4. Staff Leisure Centre Membership Subsidy

The Shire offers permanent full time and part time employees the ability to purchase a single or family membership for the Narrogin Regional Leisure Centre at a 50% discount of the adopted annual rates to encourage fitness and general wellbeing within the workforce. Note: this does not include coordinated sports activities.

5. Smoke Free Workplace

The Shire is committed to promoting a smoke free workplace.

Smoking in the following places is prohibited –

- All Shire buildings,
- All Shire vehicles and plant,
- The Depot office, workshop, the bottom lean-to (plant and chemical storage) or within 20 metres of the diesel transfer tank

- Within 5 metres of access points to buildings such as doors, windows, near air conditioning vents and ducts
- Courtyards
- Other areas designated as non-smoking areas by signage

The underpinning principle being that non-smokers shall not be subjected to smoke inhalation, therefore if you are asked to move away or extinguish a cigarette, you must comply with the request.

Ensure that cigarette butts are dealt with appropriately. They must be put out, picked up and disposed of in the appropriate receptacle – they are not to be disposed of in flowerbeds, walkways etc.

6. Staff Support Services

a) Access

The Shire offers staff support services, in the form of confidential counselling services through LGIS, to assist employees experiencing personal and/or work related issues.

The services are offered to all employees of the Shire and are designed to be short-term. Use of the services provided is on a voluntary basis and is free to employees.

If a problem cannot be resolved by the individual's own efforts or through other means, the LGIS counselling service can be accessed by –

- Manager referral - in some cases, managers may suggest to employees that they may benefit from utilising the counselling service. In this case referral to LGIS counselling services should be kept confidential between the manager and the employee, or
- Internal Contact – employees may contact the Executive Manager Corporate and Community services to organise referral. Alternatively, employees may access the service at their own discretion. Workers and managers can access the service by phone or email (face to face if availability permits) enabling them to receive confidential counselling support wherever they are based.

LGIS can be contacted by –

- phoning 9483 8857,
- email admin@lgis.wa.com.au, or
- <https://www.lgiswa.com.au>

b) Number of Sessions

The counselling services provided by LGIS are primarily 'stress counselling' and of a short-term nature. Sessions are generally one hour in duration. The service is available between 8.30am and 5.00pm Mondays to Fridays. Sessions are predominantly phone based. Upon special request, face to face counselling can be organised depending on availabilities.

If the psychologist considers the issue to require ongoing counselling or long term therapy, resources will be provided to the employee to sought alternative support (for example, through the Better Access scheme via a doctor's referral or local resources available within the community).

c) Leave Provisions

In the event that the employee desires to ensure that their manager is not aware that they are undertaking counselling, then the employee should organise sessions to be completed during non-working hours. The arrangement for taking time off during work hours will be the same as for any form of absence from the workplace, including time in lieu, however the manager does not need to be informed of the referral or the specifics of the matter.

d) Confidentiality

A significant feature of the LGIS counselling service is the high level of Confidentiality and the respect for the employee's privacy. All employees utilising the service are required to sign a confidentiality agreement to enforce this.

Information on all referrals to LGIS counselling services will be in strict confidence. Confidentiality means that the Shire will not receive any information from LGIS concerning the employee's problem. Employees will need to provide written consent to release their personal information, should they choose to share their counselling information to a third party.

Provider – LGIS counselling services should be contacted by the employee for an appointment.

7. Communication

The Shire will ensure that –

- All employees receive a copy of this policy during the induction process.
- This policy is easily accessible by all members of the organisation.
- Employees are empowered to actively contribute and provide feedback to this policy.

– End of Policy

Notes

9.5 Workplace Visitors – Management

Statutory context Occupational Safety and Health Act 1984

Corporate context None

History

Adopted	26 April 2017
Last reviewed	24 July 2019
Last reviewed	7 June 2021

Policy Statement

1. The Shire is committed, to ensuring that visitors to workplaces are not exposed to hazards as far as reasonably practicable.
2. Severe penalties apply under the Occupation Safety and Health Act 1984 if visitors to workplaces are injured through not being appropriately cared for.
3. Visitors to workplaces are required to comply with the directions of staff by the OSH Act s.57A.
4. All locations –
 - a) Visitors who wish to move around the location must be accompanied by a Shire employee at all times, with the exception of authorised contractors/subcontractors.
 - b) Employees are to ensure that all walkways and access/exit points remain clear of obstacles at all times.
 - c) Prior to being authorised to enter a workplace/worksites which has known hazard/s, all visitors must be provided with a workplace specific induction on the nature of the hazard/s within that location and must be instructed in any emergency evacuation procedures.
5. Offices and similar locations –

All visitors are to report to the front counter, where applicable, or to the appropriate Manager / Supervisor before entering the workplace/worksites.
6. Depot Workshop and Yard –

Prior to entry into the depot workshop or yard, all visitors, contractors and subcontractors are to report to the depot office.
7. Construction and maintenance sites and similar locations –
 - a) Prior to entry to a construction/maintenance site, all visitors, contractors and subcontractors are to report to the site manager or supervisor.
 - b) High visibility workwear is mandatory for depot yard and worksites.
 - c) Appropriate footwear and PPE for the purpose is mandatory.

– End of Policy

Notes

9.6 [Risk Management](#) - Deleted

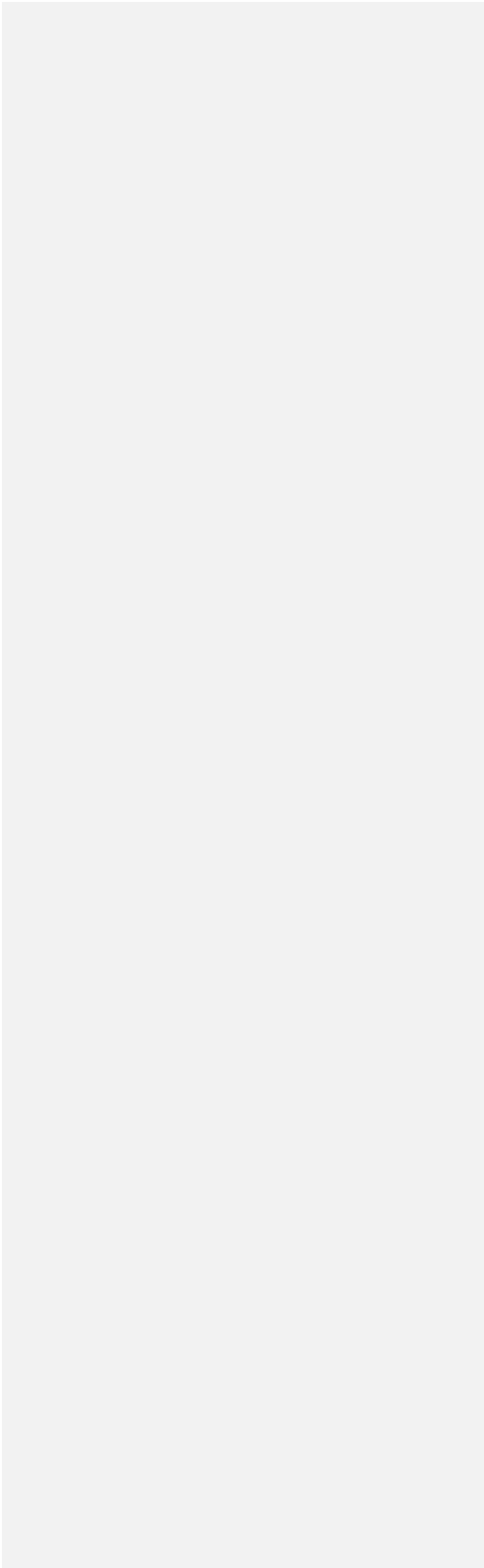

Section 10 - BUILDING / DEVELOPMENT

10.1 Kerb / Footpath Deposit – Adjoining Works

Statutory context Building Act 2011
Building Regulations 2012

Shire of Narrogin Public Places & Local Government Property Local Law 2016

Corporate context Delegation 10.3 – Control of Planning Matters

History Adopted 26 April 2017
Last reviewed 24 July 2019
[Last reviewed 7 June 2021](#)

Policy Statement

1. Where the estimated value of building / demolition developments exceeds \$20,000.00, a kerb / footpath deposit is required to be paid to the Shire of Narrogin by the applicant.
2. The following conditions apply –
 - a) The kerb/footpath deposit must be paid to the Shire of Narrogin before a building/demolition permit can be issued.
 - b) Loading and unloading of steel track machinery on the road without the use of rubber tyres or timber, will result in no refund of your kerb/footpath deposit.
 - c) All development material including sand, bricks and timber must be cleaned from the footpath and road verge area at the completion of the development
 - d) All damage to kerbing, footpaths, verge and road area caused during the development, must be repaired prior to requesting a refund.
3. The deposit is to be held in Council's Trust Fund.
4. Once the development has been completed, and a request for refund of the deposit has been received, an appropriate person is to conduct a site inspection.
5. If there is damage to the kerb, footpath, verge or road surface, the cost of repair is to be deducted from the deposit prior to refund being made
6. If approved, a refund for the authorised amount is to be issued to the person who lodged the original deposit.
7. If the cost of repairing the damage exceed the deposit amount, and invoice for the balance is to be issued to the property owner or contractor.

– End of Policy

Notes

10.2 Shade Cloth Structures

Statutory context Building Act 2011
Building Regulations 2012

Corporate context None

History Adopted 26 April 2017
Amended 24 July 2019
[Last reviewed 7 June 2021](#)

Policy Statement

1. Upon application, approval may be given to use shade cloth to cover or enclose an area between a patio, pergola, carport or garage and an adjoining fence –
 - a) within the side and rear setbacks of residential properties within town sites,
 - b) the structure shall be of shade cloth supported on a light weight framework of metal installed between the roof of the adjacent structure and below the top of the boundary fence,
2. Prior to approving a shade cloth structure up to a boundary, an appropriate employee shall refer the application to the adjacent landowners/occupiers for comment over a minimum 14 day period.
3. Shade cloth structures will not be permitted within the front setback of any property.
4. Approval may be granted to such structures where no objections are received during the comment period. All other applications shall be referred to Council for determination.

– End of Policy

Notes

10.3 Colour Palette and Sign Guide (Central Business Precinct)

Statutory context	None	
Corporate context	Colour Palette Guide & Signage Guide	
History	Adopted	28 July 2020
	Last reviewed	7 June 2021

Policy Statement

The Central Business Precinct

This Policy applies to the Central Business District (CBD). The Central Business Precinct is bounded by the southern side of Clayton Road, Federal Street, Fairway Street, Park Street and Earl Street as defined in the former Town of Narrogin Town Planning Scheme No.2 as depicted in the plan below.

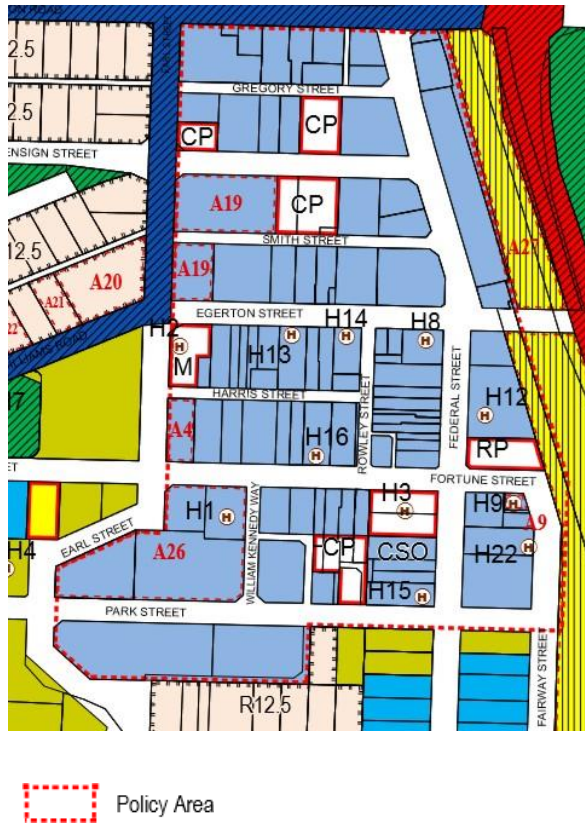

Former Town of Narrogin Town Planning Scheme No. 2 – Scheme Map

1.0 COLOUR PALETTE

1.1 Objectives

The objectives of this policy are to:

- Encourage proponents within the CBD Precinct, if they intend painting the exterior of their property or affixing or altering signage to their property, to lodge a Development Application to the Shire for assessment in accordance with this Policy.
- Create a consistent colour palette applicable to development using colours from the Town Centre Colour Palette Guide developed by H+H Architects;
- Strengthen the identity of the Central Business Zone;
- Provide guidance to Council, private landowners and developers on the appropriate external colours for new or existing development;
- Encourage where possible, original colour schemes to enhanced the heritage building, streetscape and the Central Business Precinct;
- Attain a high quality visual streetscape; and
- Preserve, enhance and complement the existing built environment.

1.2 Policy Statement

An integral part of the '2016 Narrogin Townscape Study Review' undertaken by H+H Architects and Malone Design is the adoption of a "colour palette" to be used as a guide by Council when it assesses new and existing development, and when it selects colours for application to public street furniture and public buildings.

The colours are considered appropriate to the Shire of Narrogin environment, and have the potential to introduce an exciting new element into the town's character.

H+H Architects has been commissioned to develop the Shire of Narrogin 'Town Centre Colour Palette Guide and Sign Guide', which is to be used as a basis for guiding developments within the Central Business Precinct and to be read in conjunction with this policy.

1.3 Policy Provisions

Colours Guidelines

- 1.3.1. Development Applications lodged that propose the treatment of the external surface of a building shall include the following information:
 - Demonstrate that the type of paint, as well as the preparation of the building and application of the paint will contribute to the conservation of the building, and will not significantly compromise the significant heritage fabric of the building.
 - Evidence of research into original colour schemes in the form of a paint scraping and/or historical research into the style of building.
- 1.3.2. Where possible, colours selected shall be consistent with the original colour schemes of the building.
- 1.3.3. Where it is not possible to determine the original colour scheme, colour selection shall be consistent with the following key principles and the Colour Palette Guide based on the era of the development (Federation, Inter-War and Post War):
 - The main body of the wall shall be natural wall colours that suggest the natural materials underneath (i.e. brick, stone or render).

- Where it is proposed to paint brick or stone quoining, colours shall be consistent with the natural materials underneath.
- Decorative elements - including cement rendered dressings (stucco), architraves, friezes, cornices, and pilasters – shall be highlighted with the use of no more than two muted tones in a lighter colour than the main body of the wall.
- Outer window frames shall be painted in dark colours (browns, deep reds, or dark greens), with light cream or white highlights accentuated in window sashes, and dividing joinery between individual window panes.
- In the case of verandahs and awnings, structural elements shall be dark tones (browns, deep reds, or dark greens) while decorative elements shall be highlighted with the use of light muted tones (cream or white).
- In the case of buildings with external timber cladding, paint colours shall be consistent with the original colour schemes of the building.

1.3.4. In addition to clause 1.2., Council shall have regard to the following:

- Any established conservation management plan relating to the site;
- Any statement of heritage impact relating to the site; and
- Any advice received from the Heritage Council of Western Australia relating to the site.

1.4 Face brickwork and Limestone Fabric

- 1.4.1. Council will not approve the rendering or painting of face brickwork or limestone fabric for buildings of recognised heritage significance unless it can be demonstrated by the applicant that it is not possible to conserve the face brickwork or limestone fabric in its current form, and painting or rendering the face brickwork or limestone fabric is the only suitable conservation treatment in the circumstances.
- 1.4.2. The sealing of exposed face brickwork or limestone fabric of buildings with recognised heritage significance is not considered appropriate and will not be supported.
- 1.4.3. In cases where treatment of face brickwork and limestone fabric is proposed, an application shall be accompanied by a technical report from a suitably qualified expert in support of the methodology to ensure that the treatment will be beneficial for the ongoing conservation of the building.

1.5 Treatment of Existing Buildings Listed in the Shire of Narrogin Local Heritage Survey 2019

- 1.5.1. Paint colours shall be compatible and complimentary to the heritage character of the existing building.
- 1.5.2. Where the external building is constructed of face brickwork and limestone fabric, treatment of external surfaces shall be in accordance with clause 1.2 of this policy.

1.6 New and Infill Development

- 1.6.1. Proposed colour schemes and finishes are to be consistent with the Colour Palette Guide and have regard to the following criteria:
- Whether the colour scheme and/or building finishes are consistent with the streetscape.
 - Whether the colour scheme and/or building finishes are likely to have any significant impact on any abutting or immediately adjacent property with recognised heritage significance.
 - The colour palette shall be used as a guide for applicants when assessing new and existing development including street furniture and public buildings within the Shire of Narrogin Central Business Precinct.

- Applicants will be strongly encouraged to use the colour palette that reflect the era of development (Federation, Inter War and Post War periods).
- Any request by an applicant to deviate from the adopted colour palette must be accompanied by detailed reasons. The CEO may approve alternative colours which are reasonably close to those contained within the colour palette, and where the overall visual intent will not be compromised.

2.0 SIGN GUIDELINES

2.1 Objectives

The objectives of this policy are to:

- Ensure consistency with the sign guidelines for the Town Centre Precinct in accordance with the Town Centre Colour Palette Guide and Signage Guide prepared by H+H Architects.
- Guide the design, materials and siting of advertising structures and signs in the Town Centre Precinct.
- Ensure that signs erected on heritage buildings, or any buildings in the Town Centre Precinct, should be compatible with the character of the building, streetscape and heritage precinct.
- Ensure that signs are located in appropriate positions on the building, be clear and easy to read from the street and not to visually dominate the building or area.

2.2 Policy Statement

This policy has been prepared to support and to be read in conjunction with Part V – Control of Advertisements of the former Town of Narrogin Town Planning Scheme No. 2 and the Shire of Narrogin Public Places and Local Government Property Local Law 2016. The scheme requires the submission of an application for Development Approval for non-exempt advertisements.

2.3 Policy Provisions

Signs above Verandah Level

Advertising panels on parapets should be used in preference to other locations. Parapet signs are to be of appropriate size and do not dominate the façade.

Only one line of advertising space should be encouraged.

Signs on Verandah and Awnings

Signs on Verandahs and Awnings should not obscure architectural detailing. A sign fixed to the outer or return fascia of a verandah or awning is appropriate provided that:

- It does not project beyond the outer metal frame or the surround of the fascia; and
- It does not obscure architectural detailing.

Signs Painted onto Display Windows

Permanent signs on windows of retail premises should cover no more than 30% of the display window and should not clutter or dominate the shopfront window.

Signs below Verandahs

Suspended signs under the verandah at right angles to the building should not exceed 250mm x 1800mm and should be at least 2.4 m above the ground level.

A sign under the verandah shall:

- Have a headway clearance of at least 2.4m
- Restricted to one (1) sign per shop; and
- Have a minimum setback of 750mm from the kerb.

Signs on Buildings without Verandahs

Signs should be restricted to:

- Parapet signs;
- Shop window signs;
- Suspended signs off wrought/cast iron brackets, maximum size 400mm x 400mm;
- Tenancy boards flat to wall adjacent to doorways.

Signs on Building Walls

Signs on side walls of buildings should be designed to complement the building expression and colour scheme.

Colour

Colours of signs should complement the overall colour scheme of the building.

– End of Policy

Notes

[Colour Palette Guide & Signage Guide](#)

Section 11 - PUBLIC FACILITIES

11.1 [RW \(Bob\) Farr Memorial Library – User Rules – Deleted](#)

11.2 Hire of Venues – General

Statutory context Local Government Act 1995

Public Places and Local Government Property Local Law

Corporate context Delegation 11.3 – Public Places & Local Government Property Local Law 2016

History

Adopted	26 April 2017
Amended	24 July 2019
Last reviewed	7 June 2021

Policy Statement

1. The following Council Policy Schedules are adopted, and form part of this Statement –
 - 11.3(a) – Hire of Venues – Requirements to Hire
 - 11.3(b) – Hire of Venues – Conditions of Hire
2. Hirer Categories –
 - a) Individual / Community –

This definition also applies to private bookings such as weddings, birthday parties, christenings etc.
A community use is defined as a non-profit organisation and shall include, but is not limited to sporting clubs, not-for-profit community groups, religious groups, education institutions, charitable institutions, service clubs and groups that have a focus on community needs with a social benefit.
 - b) Professional / commercial user –

A professional / commercial user or group is one whose intention it is to result in private gain (i.e. income generation).
Those user groups deemed to be of a commercial nature would be charged the standard fee for use of the facilities.
3. Compliance with the following is mandatory –
 - a) Liquor Licencing Act,
 - b) Public Health Act,
 - c) Police Act,
 - d) Criminal Code, and
 - e) Relevant Shire Local Laws.
4. A permit for the sale and/or consumption of alcohol from the Clerk of Courts is required to be presented, prior to the Shire giving approval for sale and/or consumption of alcohol.
5. Each approval for consumption or sale is to be notified to the Narrogin Police.
6. Equipment from facilities is not available for outside usage except with the approval in writing of the CEO or Executive Manager Corporate and Community Services, and is subject to hire fees, bond charges etc.

– End of Policy

Notes

[Public Places & Local Government Property Local Law also applies.](#)

Policy Schedule 11.2(a) – Hire of Venues – Requirements to Hire

1. Bookings
 - a) Bookings will only be held for 7 working days without payment or purchase order.
 - b) To confirm a booking, full payment of fees and bond, within 7 working days of booking, unless specific approval is given.
 - c) If an agreed deposit payment has made, full payment is required at least 14 days prior to booking date.
 - d) Bookings made less than 14 days prior to booking date must be paid in full immediately.
 - e) Bookings made without allowing sufficient time for preparation of the venue during normal work hours, may attract an extra charge if work outside of usual hours is required.
 - f) Permanent or ongoing bookings will be billed annually or monthly in advance.
 - g) The Shire reserves the right to refuse to let a venue or any portion thereof.
 - h) Tentative bookings will be accepted not more than 12 months in advance.
 - i) Multiple year bookings will not be accepted.
2. Double Bookings
 - a) In the event that two applications for bookings are received on the same day for hire of the same facility, the relevant employee or CEO may determine to which applicant the hiring will be granted. Generally, precedence will be given to the earlier booking, although the applicants are encouraged to negotiate a mutually agreed arrangement.
3. Cancellations
 - a) Cancellations by the user without penalty can be made up to 14 days prior to the booking date, with full fee refund.
 - b) Cancellation by the user within 14 days of the booking date may result in forfeiture fees and of the bond unless there are extenuating circumstances.
 - c) The Shire reserves the right to at any time cancel an agreement for hiring of a venue. Notice of cancellation will be given at the earliest possible opportunity and all monies refunded.
4. Bonds
 - a) Bonds to cover damage and cleaning must be paid at the time of confirmation of the booking date, and are refundable provided there is no cause for complaint.
 - b) An additional bond will be charged for every function at which alcohol will be available.
 - c) Any damage, excluding fair wear and tear, may result in forfeiture of part or all of the bond.
5. Fees and Charges
 - a) Hire fees and charges for use of Council facilities, including any furniture or equipment, shall be determined from time to time by the Council. (see Fees and Charges in the Annual Budget)
 - b) The Shire reserves the right to grant a reduction / concession of all or any part of hire charges in special circumstances.
 - c) The CEO has authority to approve a fee reduction case in accordance with Delegation 3.11 Donations – Financial and In-kind Works / Services.
6. Facility Availability
 - a) Council facilities are available on a casual basis.
 - b) All hirers of Council facilities must be 18 years of age or over and be legally responsible for the function, event or activity nominated on the hire form.
 - c) Hirers may be required to provide proof of age and an address on the relevant hire application.
 - d) The hirer or nominated representative (over the age of 18 years) must be in attendance for the duration of the function, activity or event, be contactable by mobile phone and be available to present hire forms and other relevant details to authorised persons when required.
 - e) At the discretion of the Shire, hirers may be required to engage suitable licensed crowd control staff at the recommended ratio for the duration of the hire period in accordance with relevant guidelines (see Note below).
 - f) The hirer will be required to provide documented evidence that such measures have been put in place.
 - g) The Shire has the right to refuse a booking application if these measures are not put in place by the hirer.

– End of Schedule

Note - Clause 6(d) "relevant guidelines" include those published by Department of Health or the Office of Racing, Gaming and Liquor.

Policy Schedule 11.2(b) – Hire of Venues etc – Conditions of Hire

Specific Conditions –

Specific conditions may be applied to particular activities, events or venues.

Standard Conditions –

Standard Conditions that apply to all activities, events or venues –

1. Use of Venue
Events/functions/activities are restricted to the times and areas approved and listed on the booking form.
2. Compliance with Laws and Regulations
 - a) The hirer of any portion of a Council facility will be required to comply with the provisions of the Liquor Licensing Act, Health Act, Police Act, the Criminal Code and any other Act or Local Law in force for the time being, applying to such hiring of the facility.
 - b) If, in the opinion of Council, all necessary actions have not been taken to comply with the requirements of the above and relevant Acts and Local Laws, the Council may, prior to or during the term of the engagement, forbid and prevent the use of the facility and all monies paid to Council shall be forfeited.
 - c) Any authorised officer of the Council shall be permitted free access to the facility during an engagement and shall be given every facility for enforcing these conditions.
3. Smoking
 - a) All Council buildings and enclosed venues are smoke free zones.
 - b) Health Act and Local Laws apply and provide for penalties for breach
 - c) In addition, breach will result in forfeit of 50% of bond.
4. Alcohol
 - a) Consumption of alcohol requires Shire approval.
 - b) Sale of alcohol requires both Shire approval and approval of the Licencing Court available from the Narrogin Police.
 - c) All approvals will be notified to the Narrogin Police.
5. Temporary Fixtures and decorations
 - a) Banners and displays advertising coming events to be held in a venue may be placed or temporary affixed by cable ties, rope etc to the external of the building or premises subject to –
 - no permanent fixtures of any kind whatsoever, is permitted, including drilling of holes,
 - being displayed for not more than 7 days prior to the event, without approval of the CEO,
 - being removed within 2 days of conclusion of the event.
 - b) All decorations, banners fixtures etc must be removed immediately after the event.
6. Specialist Turfs
 - a) The turf cricket pitch located at Clayton Road Oval and the Croquet Greens are classified as specialist turfs.
 - b) In determining the fees and charges for the use of specialist turfs, Council shall consider the cost of the maintenance cost of these surfaces from each Permanent Seasonal User using these surfaces.
7. Line marking
 - a) Line marking within a building may only be of adhesive tape, which is to be removed immediately after the event.
 - b) Line marking on reserves, sportsgrounds and parks may be completed using white PVA paint or English whiting only.
 - c) Line marking on any paved surface that will leave permanent traces is not permitted, and is subject to specific prior approval.
 - d) The use of lime, creosote or diesel in any form for line marking is not permitted.
8. Breach of Conditions of Hire
 - a) A breach of conditions of hire may result in the immediate termination of hire of the venue.
 - b) If warranted, action may be taken under relevant legislation, the Public Places and Local Government Property Local Law or both.

9. Damage to premises or excessive cleaning requirement
 - a) Damage to premises or excessive cleaning requirement may result in all or part of the bond paid will be retained to cover expenses for repair or cleaning.
 - b) If the bond is insufficient to cover expenses, action to recover the outstanding costs is likely under the Shire of Narrogin Public Places and Local Government Property Local Law.
10. Additional Equipment
 - a) Council facilities are fitted with a certain amount of equipment. Any additional equipment is to be provided by the hirer at the hirer's expense.
 - b) Appropriate facilities are supplied with tables and chairs as per regulations accommodation numbers. A hirer requiring additional tables and/or chairs must meet the following guidelines –
 - i) Maximum room accommodation numbers must not be exceeded;
 - ii) Tables/chairs cannot be moved from another Shire facility; and
 - iii) It is the responsibility of the hirer to source and pay for the additional tables and/or chairs and their delivery and removal from the premises at the conclusion of the designated booking time.
11. Waste disposal
 - a) The Shire will supply and service a maximum number of bins for each Council facility.
 - b) Any additional bins required by hirers for events or functions will be supplied and serviced at the cost of the hirer.
 - c) The number of bins to be provided at each facility is determined based on individual facility normal usage.

– End of Schedule

11.3 Hire of Venues – Annual or Seasonal Use

Statutory context	Local Government Act 1995
	Public Places and Local Government Property Local Law
Corporate context	Delegation 11.3 – Public Places & Local Government Property Local Law 2016
History	Adopted 26 April 2017
	Last reviewed 24 July 2019
	Last reviewed 7 June 2021

Policy Statement

1. Permanent Seasonal Users
 - a) Each club or organisation using a venue on a permanent or seasonal basis shall be required to pay a fee for such usage.
 - b) That fee shall be based on a percentage of the maintenance costs of each venue, and is inclusive of all maintenance costs attributable to the upkeep of the venue (e.g. water and electricity).
 - c) The cost of any work requested by permanent seasonal users that is not included as part of the normal maintenance shall be met in full by the user group requesting that work.
 - d) Additional maintenance work shall only be carried out provided the Shire receives a written request for the work not less than 28 days prior to that work being required to be complete. Any such additional work must be requested, in writing by an authorised person of the user.
 - e) The Shire's responsibility in clearing rubbish from venues after events is limited to emptying bins. Any additional cleaning work carried out by Shire employees will be charged at private works rates to the user concerned. Toilets etc. will be maintained and cleaned at no charge during week days but where weekend cleaning is required appropriate charges will be made.

– End of Policy

Notes

Public Places & Local Government Property Local Law also applies.

11.4 Public Art Contribution Policy

Statutory context	Nil
Corporate context	Shire of Narrogin Public Art Strategy & Masterplan 2019 Public Art Contribution Policy Guidelines
History	Adopted 25 August 2020 Last reviewed 7 June 2021

Policy Statement

1. INTRODUCTION

Public art is mostly located in public places and spaces but may also be incorporated into private areas open to the public such as shopping plazas, schools, parks, town centres, streetscapes and buildings. It can be a literal piece of artwork such as a sculpture, a painting, a wall mosaic or a mural. It can be incorporated into a functional object including paving, water features (such as a fountain), seating, bridges and lighting. It can also be a temporary work such as an art performance in an outdoor public space.

Public art contributes to the identity of a place in a range of ways. This includes interpreting local culture and customs, enhancing the overall design and visual appearance of a place and adding to the vibrancy, liveability and familiarity of a place through the creation of memorable experiences and landmarks. Public art is often created by local communities themselves and is enhanced with the help of experienced community artists.

2. POLICY OBJECTIVES

The Shire of Narrogin Public Art Contribution Policy aims to:

- Support the implementation of the Shire of Narrogin Public Art Strategy & Masterplan 2019;
- Facilitate the creation of original, high quality public artworks sited in a visually accessible public location;
- Contribute to the arts and cultural development and the fabric of daily life in Narrogin;
- Create a vibrant and contemporary sense of place whilst also respecting and responding to Narrogin's existing history, culture and aspirations;
- Encourage arts engagement, and interaction with places and spaces in Narrogin; and
- Infuse qualities of diversity, creativity and character through themes, types of art and approach.

The Public Art Contribution Guidelines for the commissioning of new public art works are to be read in conjunction with this Public Art Contribution Policy.

3. DEFINITIONS

Artist: In this policy Artist means a person who meets two or more of the following criteria:

- Has a track record of exhibiting/selling their artworks in reputable galleries or public spaces;
- Earns over 50 percent of their income from art related activities such as selling works or public art commissions;
- Has a Bachelor Degree or Diploma qualification in visual or fine art, or other art forms where relevant; or
- Can otherwise demonstrate that they have artistic expertise.

Public Art: For the purpose of this policy, public art is broadly defined as work or activity designed and/or fabricated by an artist, installed in public space and accessible to the general public. The work may be temporary or permanent, located in a public space or facility provided by both the public and private sector (this includes areas within private buildings that are easily accessible by the public). Public art also includes the contribution of a conceptual idea by an artist to the design of a public space or facility.

As part of this Public Art Contribution Policy, public art can include (but is not limited to):

- The artistic treatment of functional equipment such as bike racks, benches, fountains, playground equipment, light posts or shade structures which are unique;
- Landscape art enhancements such as walkways, bridges or art features within a garden;
- Murals, tiles and mosaics covering walls, floors and walkways and sculptures, free-standing or incorporated as an integral element of a building's design.

Public art does not include:

- Business logos.
- Advertising signage.
- Art objects which are mass produced or off-the-shelf reproductions.
- Landscaping or hardscaping which would normally be associated with a development.

Owner: means the owner of the land upon which the relevant development is proposed to be built. The Owner may also be the Applicant.

Construction Cost: In this policy construction cost means all costs associated with the preparation, construction and full completion of a development, including all materials, labour, servicing and ancillary costs. To ensure accurate calculation of public art contribution values the Shire if necessary may require an applicant to provide cost breakdowns and/or certification from a quantity surveyor to confirm construction cost.

4. POLICY STATEMENT

Narrogin Shire Council aims to either acquire or commission and complete, at a minimum, one public artwork every two years. The Council recognises that best practice public art projects can only be achieved through the allocation of adequate budgets.

Council's financial contribution to public art will be through a number of approaches. These are set out below:

I. Percent for Art Scheme

Council may enter into a planning agreement with developers contracted to undertake new building works or refurbishments. The Western Australian State Government Percent for Art Scheme's offers a guide for this approach. Since 1989, this Scheme has allocated up to one percent of the estimated total construction cost of each State capital works project, valued at \$2 million and over, to a commissioned Western Australian artwork.

The Shire's Percent for Art approach requires that half a percent (0.5%) of the estimated construction cost (over \$2 million) is attributed to Public Art. The Shire's contribution requirement shall be imposed on applicable developments as a condition on the Planning Approval. The condition shall specify that the contribution must be made prior to commencement of the project.

Where Council determines a public art contribution applies the owner/applicant can choose to either make a cash in lieu contribution or coordinate a public art project.

Option 1: Cash in Lieu

It is recommended developers provide cash in lieu to the Shire of Narrogin for public art budgets up to \$25,000 but can provide cash in lieu for budgets over \$25,000 at their discretion.

Option 2: Coordinate a Public Art Project

The procurement of a public art project with budgets of \$25,000 and above, will be in accordance with the Shire of Narrogin's Public Art Strategy & Masterplan 2019 and the Public Art Contribution Policy Guidelines. It is recommended more complex public art projects are managed for the owner/applicant by an external public art consultant, unless there is a permanent role created within the Shire.

Costs associated with the production of public art include the following:

- Artist fees, materials, assistant's time, insurance, permits, business and legal expenses and operating costs;
- Fabrication and installation of the art work;
- Art consultant fees (maximum 15% of the budget);
- Site preparation, documentation of the art work and acknowledgement plaque.

Upon choosing Option 1, Cash in lieu full payment must be made to the Shire prior to submission of a building permit.

Upon choosing Option 2, the Owner/Applicant will review the Shire of Narrogin Public Art Strategy & Masterplan 2019 as well as the Shire of Narrogin Public Art Contribution Policy Guidelines and the Public Art Commissioning Process.

The percentage spent on public art and the threshold value will be reviewed by Council at the commencement of each financial year setting the minimum amount for which developments are required to contribute to public art. The amount will be set out in the Shire's Prescribed 'Fees and Charges'.

II. Infrastructure projects with a component of built-in artwork, funded under the Council's annual capital works program

Every year and in the process of developing the new financial year's draft capital works program, the Shire's Executive and the Manager Community Leisure & Culture will review the building program and nominate projects which offer the best opportunities to integrate public art. This process requires Shire officers to carefully consider, in advance, how public art may be assimilated within the design and construction of public facilities or their improvement works. Examples of infrastructure projects which could include a built-in art component are artist-designed alternative paving treatments, bridges, treatment to building facades, new fencing and new street furniture. Nominated infrastructure projects will be costed and submitted for Council's endorsement as part of its budget process.

III. Annual Budget Allocations

Council will consider public art opportunities as part of its annual budget and annual budget review process and consider it appropriate to allocate a special budget to acquire or commission a piece of stand-alone or iconic public artwork.

IV. Grant Funding

Council may obtain grant funding from a State or Commonwealth source, an arts institution or receive sponsorship from a philanthropic organisation or the private sector. Community groups may also propose public art funded by another source and seek to form a partnership with the Council.

5. SUSTAINABILITY AND PUBLIC ARTWORKS

The Council commits to implementing ecologically sustainable practices as part of all of its facilities and activities including the planning, design, and implementation of all outdoor public art projects. This includes the use of renewable (green) materials and technologies in artists' designs, fabrication and installation processes. The Council will also seek to acquire artworks that are appropriate to the environment in which they are to be installed e.g. outdoor artworks should be highly durable, resistant to vandalism and require low maintenance.

The Owner/Applicant seeks the Shire's approval for their chosen professional artist, enters into a contract with their approved chosen professional artist, and submits an Application for Artwork to the Shire. The application is reviewed internally by the Shire of Narrogin Public Art Advisory Panel. Once the Shire is satisfied, the project is given full approval.

Procedures

Corporate Library - [Public Art Contribution Policy Guidelines](#)

Forms and Templates

[Public Artwork Approval Application Form FDRS036](#)

– End of Policy

Notes

11.5 Advertising / Sponsorship signs – in Shire buildings and facilities

Statutory context	Local Government Act 1995 - s.6.16 – imposition of fees and charges Shire of Narrogin Public Places and Local Government Property Local Law
Corporate context	Delegation Register – - 11.3 – Public Places and Local Government Property Local Law 2016
History	Adopted 28 April 2021 Last reviewed 7 June 2021

Policy Statement

General

1. The purpose of this policy is to set the requirements for fixed promotional, advertising and sponsorship signs on the internal walls, the external structure of the buildings and associated external structures of –
 - a) Narrogin Regional Leisure Centre; and
 - b) John Higgins Centre.
2. Naming or advertising within or on any other area is subject to application to the local government, or in accordance with any other relevant Council Policy.
3. The Narrogin Regional Leisure Centre (NRLC) and John Higgins Centre (JHC) are facilities under the control and management of the local government, whose day to day operations may be contracted out from time to time.
4. Where the day to day operations of the NRLC and the JHC are contracted out and the contract provides for funding by the Shire of any deficit of operations incurred by the facility manager –
 - a) all revenue raised from advertising or sponsorship signs, other than life time sponsors, will be retained by the facility manager, thereby reducing the deficit that is contractually required to be met by the Shire;
 - b) should the operations of the facility generate a surplus, the revenue raised from advertising or sponsorship signs will be equally divided between the Shire and the facility manager.
5. Permanent signs are not permitted in other areas, unless of a nature that is –
 - a) statutory or regulatory requirement or compliance;
 - b) directional or information approved by the local government or the facility manager.
6. No advertising is to interfere or detract from emergency notices or equipment in any way at any time, including but not limited to –
 - a) emergency access, exits, signs or instructions;
 - b) fire hoses and extinguishers;
 - c) defibrillators, first aid kits or equipment, etc.
7. Nothing in this policy prevents individual regular user sporting associations or clubs from soliciting for and receiving income for annual sponsors signs to be affixed within their predominate area of use, subject to –
 - a) such signage being administered by the relevant association or club;
 - b) compliance with the provisions of this Policy;
 - c) such signage not exceeding 60cm by 60cm and totalling no more than 3 in number;

- d) signs in excess of 60cm x 60cm are subject to clause 13, with the charge to be equally split between the club and the facility manager.

Permitted signs and duration

8. Advertising permitted –

Sponsor / advertiser	Permitted	Duration
Shire of Narrogin	As determined by Council or CEO	As determined by Council or CEO
Facility manager	As approved by CEO	Duration of contract
Life time sponsor	As determined by Council	Permanent while the sign remains in satisfactory condition or replaced
Facility construction contributor	a) Honour Board, location determined by CEO b) Appropriate location throughout the facility	a) Permanent – permanent honour board; and b) Minimum of 5 years – on plaques throughout the facility
Naming rights sponsor	As determined by Council	Maximum period of 5 years, renewable
Fixture sponsor eg – basketball backboard, scoreboards, water polo goals, pool lane dividers, gym mats	As determined by CEO	While the fixture remains in satisfactory condition – - Where the fixture is provided by the sponsor – maximum period of 10 years, renewable - Otherwise – maximum period of 5 years, renewable
Long term sponsor	As determined by CEO or facility manager	Maximum period of 5 years, renewable
Seasonal sponsor	As determined by CEO or facility manager	Maximum period of 1 year, renewable
Event sponsor eg – (sandwich boards, free-standing or tied banners)	As determined by facility manager	Duration of the event only
Community / not for profit / service group	As determined by CEO or facility manager	Maximum period of 5 years, renewable
Public service signs / notices	As determined by CEO or facility manager (eg: health, resuscitation, emergency procedures etc)	

9. Life time sponsors –

- a) naming plaque of an appropriate size placed in a position as agreed by Council, usually over or adjacent to the entrance of the area being named;
- b) a description or explanation plaque to be placed at a suitable height for reading on the wall in close proximity to the naming plaque;
- c) size of both naming and explanation plaques to be as approved by Council or CEO; and
- d) as at the date of adoption of this policy are –

Sponsor / advertiser	Name of area sponsored	Area purpose
Alf Jenkins (Estate) https://www.smh.com.au/national/farmer-leaves-11-million-to-neighbours-20040314-gdijcu.html	Alf Jenkins Stadium	Basketball / netball stadium

10. Facility construction contributors –

- a) name placed on an honour board, located in a position approved by the CEO and retained on the honour board permanently;
- b) acknowledgment plaque, placed in an appropriate position, retained for a minimum of 5 years and for as long thereafter as is practicable, but may be removed or relocated if necessary; and
- c) size of acknowledgement plaque to be approx. 5cm x 30cm.

11. Naming rights sponsors –

- a) size of naming signs are to comply with clause 13; and
- b) as at the date of adoption of this policy are –

Sponsor / advertiser	Name of area sponsored	Area purpose
Elders	Elders Court	Basketball, netball, soccer, volleyball, indoor cricket.
Great Southern Fuel Supplies	Great Southern Fuel Supplies Court	Netball, badminton
Nepowie Stud	Nepowie Court	Basketball, netball, soccer, volleyball, indoor cricket

Fees and charges

12. Advertising charges are –

- a) based on size in accordance with clause 13;
- b) adopted by Council in the annual budget in accordance with the Local Government Act 1995 s.6.16, or varied from time to time, and may include but are not limited to –
 - charge for standard sizes;
 - any discount for multiple years; and
- c) will be applied as follows –

Sponsor / advertiser	Basis of charge	Conditions
Shire of Narrogin	No charge	n/a
Facility manager	No charge	n/a
Life time sponsor	No charge	As determined by Council Significant contribution to the capital infrastructure of facilities
Facility construction contributor	No charge	Contribution to construction of facilities
Naming rights sponsor	As per fees & charges adopted by Council	As determined by Council
Fixture sponsor	Full cost of fixture	n/a
Long term sponsor	As per fees & charges adopted by Council	On basis of size and term
Seasonal sponsor	As per fees & charges adopted by Council	On basis of size and term
Event sponsor	No charge for temporary signs that are not fixed	As determined by CEO or facility manager
Community / not for profit / service group	No charge if a regular user / hirer	On basis of size As determined by CEO and facility manager
Public service signs / notices	No charge	As determined by CEO and facility manager
Oversize	As determined by Council	

Sign requirements

13. Size of advertising or sponsorship signs, where not elsewhere specified –
 - a) small – up to 60cm x 90cm;
 - b) large – up to 120cm x 240cm; and
 - c) oversize – as approved by Council.
14. Position of advertising or sponsorship signs –
 - a) will not be permitted in the foyer, except as approved by Council or CEO;
 - b) requested positions to be identified on application, including order of preference if multiple positions are to be considered; and
 - c) will be as agreed by the Council, or CEO and facility manager.
15. All costs associated with advertising or sponsorship signs are to be met by the sponsor / advertiser, including –
 - a) any insurances that may be considered necessary or appropriate;
 - b) design, production and installation in the approved position;
 - c) maintenance of the sign or fixture, unless agreed prior to installation in writing by the CEO and facility manager;
 - d) removal of any graffiti on the sign; and
 - e) removal of the sign or fixture, and any building repair necessary at the conclusion of the agreement.
16. All signs must be approved by the local government and facility manager, including but not limited to -
 - a) design – artwork, limitation of damage to buildings, minimise risk to facility users and possibility of damage to any services;
 - b) wording;
 - c) colour scheme and patterns;
 - d) proposed position; and
 - e) any other matter considered relevant.
17. No advertising or sponsorship sign will be permitted that could be considered –
 - a) offensive or discriminatory in language, image or implication; or
 - b) to be promoting smoke/tobacco or alcoholic products; or
 - c) contrary to the values of the local government in the opinion of the CEO.
18. The installation and dismantling of signs must minimise –
 - a) risk to users of the facility; and
 - b) possibility of damage to services.

Non-compliance

19. The local government reserves the right to require removal of any sign for any reason by giving at least 6 months' notice, and will refund the portion of any fee in advance charged, pro-rata.
20. The local government reserves the right to obscure or remove any sign, without prior notice –
 - a) has not been approved;
 - b) having offensive language or images;
 - c) not adequately maintained, including free of graffiti;
 - d) is considered unsafe to users; or
 - e) remains installed after the termination of the agreement.
21. The Shire of Narrogin local laws apply to any agreement.

End of agreement

22. At the termination of the agreement –
- a) signs to be removed by the advertiser within 1 month; or
 - b) if not removed, the Shire will remove and will charge the advertiser at private works rates.
23. At the termination of the agreement the advertiser will be given first option to renew, subject to any limitations that may have been placed on –
- a) on the number of signs or type of sign; or
 - b) number of advertisers of similar products or services.
24. The facility manager is to maintain a register of –
- a) all approved signs;
 - b) it's position within the facility; and
 - c) dates of approval/installation and termination of the agreement.

Transition

25. Signs in place at the date of adoption of this policy may remain in place without charge for –
- a) 3 months after adoption of this policy; or
 - b) the duration of any prior written agreement.

Procedures

Nil

Forms and Templates

Form to be developed.

– End of Policy

Notes

Former Section 12 – Tourism replaced

Section 12 - TRANSPORT (renamed)

12.1 Standard Crossovers

Statutory context	Local Government Act 1995 – <ul style="list-style-type: none">- S9.1(7) – crossing from public thoroughfare to private land or thoroughfare Uniform Local Provisions Regulations 1996 – <ul style="list-style-type: none">- r.12 – application and approval for crossing- r.13 – requirement to repair- r.15 – obligation to meet at least 50% of the cost of a standard crossover as defined by Council Public Places and Local Government Property Local Law
Corporate context	None
History	Adopted 26 April 2017 Formerly Policy 13.1 Last reviewed 24 July 2019 Last reviewed 7 June 2021

Policy Statement

1. The Shire will meet 50% of the cost of construction of a standard crossover giving access from a public thoroughfare to the land, or a private thoroughfare serving the land, subject to –
 - a) prior approval of proposal and estimated cost of construction of a crossover,
 - b) written agreement of the landowner/occupier prior to commencement of works,
 - c) by payment of the actual contribution cost to the landowner / occupier on completion, or cost recovery by the local government from the landowner / occupier.
 - d) any variation to a standard crossover is to be at full cost to the land owner.
2. A standard urban crossover specification is –
 - a) one crossover per property,
 - b) where adjoining road is bitumised, from the bitumen edge of the road to the property boundary, with the following materials –
 - reinforced concrete – up to 2.5 metres wide, 125 mm thick,
 - bitumen seal – up to 2.5 metres wide, 2 coat seal on 150mm compacted gravel base course
 - asphalt – up to 2.5 metres wide, minimum 60mm thick on 150mm compacted gravel base course
 - if gravel / natural surface – to 4.0 metres wide, 150mm compacted gravel
 - c) standard length of a crossover is 6 metres from the bitumised edge of the road, but may be varied where circumstance are deemed appropriate,
 - d) where the adjoining road is not bitumised, as per standard rural crossover specifications (clause 3) except to a width of 4.88m wide,
 - e) drainage under the crossover at Shire cost if required.
3. A standard rural crossover specification is –
 - a) one crossover per lot or location adjoining a road.
 - b) from the trafficable surface of the road to the property boundary,
 - c) compacted gravel, minimum 7.32 metres wide,

- d) appropriate longitudinal drainage if required.
4. Local government costs –
- a) any impact to kerbing,
 - b) impact on longitudinal drainage in place, up to 3 standard lengths of reinforced concrete pipe under the crossover cost if required,
 - c) if crossover affected when carrying out works on the adjoining road.
5. Applicant's costs –
- a) kerbing not at the edge of the thoroughfare,
 - b) costs in excess of a standard crossover construction as defined in clause 2,
 - c) costs for crossovers in addition to standard number.

– End of Policy

Notes

12.2 Roads – Developer Subdivisions

Statutory context Local Government Act 1995

Shire of Narrogin Town Planning Scheme No. 2
Town of Narrogin Town Planning Scheme No. 2

Public Places and Local Government Property Local Law

Corporate context None

History
Adopted 26 April 2017
Formerly Policy 13.2
Last reviewed 24 July 2019
Last reviewed 7 June 2021

Policy Statement

1. Definitions –
subdivision includes creation of lots or locations –
 - a) requiring new roads (“internal roads”) to be constructed whether on previously privately owned land or an unmade road reserve, and
 - b) adjoining existing made roads, whether the standard of construction of the adjoining road needs to be upgraded or not.
2. A developer shall at their own expense, bring the roads to the standard required to adequately service the subdivision, where –
 - a) a subdivision is approved and –
 - the existing roads serving the lots to be subdivided require upgrading, or
 - the lots to be subdivided do not have constructed road frontage
 - b) a subdivision road adjoins two different land zonings, the higher standard shall be applied to the whole length of the road, unless varied by specific resolution of Council, and the developer required to –
 - the developer or user will be required to fund the cost of all materials required for the upgrading above the standard considered adequate by Council or requested by the user, and
 - Council will fund all labour costs and materials required to meet the standard considered adequate.
 - c) an “internal” road is required in a subdivision estate, the road is to be vested in the Crown, without encumbrance.
3. Road construction is the responsibility of the developer, and shall be at the full cost of the developer, including any costs incurred by Council, previously notified to the developer, such as civil engineer assessment, inspection or certifications.
4. Details of the proposed road to be constructed are to be submitted to Council and approval obtained prior to any commencement of work.
5. Council may enter into a written agreement to construct or upgrade a road to the required standard where –
 - a) necessitated by a new or adjoining development,
 - b) if Shire work commitments permit, and
 - c) users request sections of a road to be upgraded to a standard higher than Council considers is warranted.

6. Council will have consideration to any relevant guidelines of Main Roads WA or Institute of Public Engineering Works Australia in determining the acceptability of the proposed –
 - road construction,
 - standards,
 - width,
 - cross-section,
 - drainage,
 - traffic conditions,
 - heavy haulage route etc.
7. During construction of the road, Shire staff or representatives will inspect the work from time to time.
8. Once the road is constructed to the proper standard, Council by specific resolution will assume all responsibility for future maintenance by specific resolution.
9. Council will not accept responsibility for a road unless inspected and certified by a mutually agreed practicing civil engineer that the road is adequate and sufficient for purpose, in accordance with the matters assessed in clause 6.

– End of Policy

Notes

12.3 Roads – Access to Lots / Locations without Road Frontage

Statutory context Local Government Act 1995

Shire of Narrogin Town Planning Scheme No.2
Town of Narrogin Town Planning Scheme No.2

Public Places and Local Government Property Local Law

Corporate context None

History
Adopted 26 April 2017
Formerly Policy 13.3
Last reviewed 24 July 2019
Last reviewed 7 June 2021

Policy Statement

1. Any lot or location without road access, or created as a result of a title adjustment, or separation of lots or locations originally on one title, shall be treated as a subdivision development.
2. Any road required to service the lots or locations is to be constructed or upgraded in accordance with Council Policy 12.2 Roads – Developer Subdivisions.
3. The sale of lots or locations without road frontage will not be approved by Council unless appropriate access has been arranged and is permanently legally enforceable by the Shire. Acceptable provision for access may include a caveat, memorial or easement over an adjoining property provided that the condition on the document cannot be removed without Shire consent.

– End of Policy

Notes

12.4 Road Reserves – Stormwater Discharge

Statutory context Local Government Act 1995
Public Places and Local Government Property Local Law 2016

Corporate context Delegation 12.1 – Reserves Under the Control of the Shire

History Adopted 26 April 2017
Formerly Policy 13.4
Last reviewed 24 July 2019
[Last reviewed 7 June 2021](#)

Policy Statement

1. An owner/occupier is permitted to discharge storm and seepage water to the street gutter via pipe drains or a sealed crossover.
2. All connections are to be submitted in writing and approved by the CEO or EMTRS, who shall have regard to any guidelines or standards of Main Roads WA.
3. Open drains are not permitted across constructed footpaths or natural surfaces regularly used by pedestrians.
4. Small connections may be approved by the CEO or EMTRS, and are to be of galvanised steel or UV stabilised high density PVC as approved by the CEO or EMTRS having regard any relevant guidelines, and –
 - a) materials to be approved by pipe with an internal diameter of 100mm, or
 - b) RHS (box section) with internal measurements 75mm and 100mm wide and between 75mm and 100mm high.
5. Connection greater than cumulative 200mm –
 - a) will require local government approval,
 - b) are to be of a suitable material or construction as approved by the CEO or EMTRS, and
 - c) where an adjacent underground stormwater drainage system in the road reserve has been constructed, are to be connected to the system having regards to any relevant standards.
6. Works can be constructed by –
 - a) subject to operational requirements, the Shire at private works rates,
 - b) by the owner and are subject to inspection by a Shire representative; or
 - c) by an appropriate contractor, holding public liability insurance of not less than \$10 million.
7. Costs that will be accepted by the local government –
 - a) Reinstatement of the installed drainage if affected when carrying out works on the road verge or the adjoining road.
8. Applicant's costs –
 - a) any piping from property boundary to discharge point,
 - b) costs of any reinstatement of footpath, road verge, kerbing required,
 - c) any connection to the underground stormwater drainage system,
 - d) inspection fees.

9. Any works which have been carried out without approval of the CEO or EMTRS or have not been constructed as approved, may be removed or altered, and costs recovered from the owners.

10. All installations remain the property and responsibility of the adjoining landowners, and the Shire accepts no liability for replacement, repair or upgrade whatsoever, except as provided for in clause 7.

– End of Policy

Notes

Clause 4 and 5(c) – “relevant standards” – refer to Institute of Public Works Engineering Australia or Main Roads WA for guidance.

12.5 Road Reserves – Closure

Statutory context Local Government Act 1995
Shire of Narrogin Local Planning Scheme

Corporate context None

History Adopted 26 April 2017
Formerly Policy 13.5
Last reviewed 24 July 2019
[Last reviewed 7 June 2021](#)

Policy Statement

Upon application, Council will consider the permanent closure of a road reserve, if –

- a) the portion of the road reserve to be closed is isolated from other road reserves, or
- b) if the road were to be constructed, it would lead to a deterioration in amenity of adjoining land (i.e.: safety, noise, dividing the property, reduced value etc).

– End of Policy

Notes

Road closures are processed by Department of Lands, as the land in a road reserve always remains the property of the Crown. While the Shire owns the infrastructure that is constructed on the roads reserve, and has responsibility for its management, care and control, the Shire does not own the land. When a road is to be closed, the Shire will be asked to comment in support or opposition, but does not have the final say.

12.6 Private Works

Statutory context Local Government Act 1995

Corporate context Delegation 12.2 – Things to be done on land not local government property

History

Adopted	26 April 2017
Formerly	Policy 13.6
Last reviewed	24 July 2019
Last reviewed	7 June 2021

Policy Statement

1. Subject to work commitments, and the capacity to carry out the requested works, private works may be authorised upon such terms and conditions as is considered appropriate –
 - a) CEO – all private works,
 - b) Executive Manager Technical and Rural Service – all private works,
 - c) Manager Operations – private works not exceeding 2 days duration
2. All private works require a written –
 - a) quote to be issued to the person requesting, and
 - b) agreement by the requesting person, unless a Local Purchase Order is supplied e.g. Western Power, Telstra etc.
3. Private works are to be charged in accordance with the fees and charges schedule as resolved by Council in the annual budget unless authorised and approved by the Chief Executive Officer.
4. Private works having the potential to affect normal Shire work programs –
 - a) are to be referred to Council prior to acceptance,
 - b) may have progress payments or other arrangements as determined by Council.
5. Other private works may be carried out at the discretion of the CEO.

– End of Policy

Notes

12.7 Road Making Materials – Non-Shire Controlled Land

Statutory context Local Government Act 1995

Corporate context Delegation 12.2 – Things to be done on land not local government property

History

Adopted	26 April 2017
Formerly	Policy 13.7
Amended	24 July 2019
Last reviewed	7 June 2021

Policy Statement

1. Where the required quantity, quality or type of material is not available from Council controlled areas and the material may be available from private property, the following is to be normal procedure –
 - a) Request permission to search for materials from the owner. Entry powers are to be used only as a last resort.
 - b) Calculate the approximate requirement for the project or yearly requirement of material from the proposed pit, and the expected life of the pit.
 - c) If suitable material is located, a written agreement is to be reached with the owner regarding compensation for materials to be removed.
 - d) Priority must be given at all times to reasonable negotiation to reach an amicable written agreement mutually acceptable to Council and the owner.
 - e) Should agreement for the removal of materials not be reached with the owner, procedures to resume an area sufficient for immediate and future needs may be instituted by specific decision of Council.
2. Compensation shall be agreed in writing prior to commencement of excavation, and may take the form of–
 - a) Works on the owner's property such as grading, gravel sheeting, drainage works, additional crossovers etc.
 - b) Resumption of the portion of land on which the materials are located will be at a mutually acceptable rate.
 - c) Compensation must be calculated in proportion to the volume of material extracted, and the impact of the activity on the property.
3. Works to rehabilitate the pit once materials have been removed shall take place and will be such works as agreed on in writing before excavation commences. These works may include –
 - a) tree planting,
 - b) deep ripping,
 - c) levelling,
 - d) stockpiling of original topsoil and spreading after extraction is completed,
 - e) creation of a dam site and roaded catchment etc.
4. All matters are to be agreed in writing, prior to removal of any materials.

– End of Policy

Notes

12.8 Directional Street Signs – Non-commercial

Statutory context Local Government Act 1995
Public Places and Local Government Property Local Law

Corporate context None

History Adopted 26 April 2017
Formerly Policy 13.8
Last reviewed 24 July 2019
[Last reviewed 7 June 2021](#)

Policy Statement

1. The CEO or Executive Manager Technical & Rural Services may approve the erection of permanent signs for sporting groups, churches, service clubs and the like at up to three locations subject to –
 - a) The application is in writing and includes the preferred wording and location for the signs.
 - b) The cost of the sign/s is to be borne by the applicant.
 - c) The standard colours of the sign/s shall be white lettering on a blue reflective background.
 - d) The size of lettering shall be a minimum of 75mm and a maximum of 100mm.
 - e) The sign plate shall be 150mm high or 200mm high with the length of the plates to be a maximum of 1 metre.
 - f) Where a sign is to be located within the road verge on a road controlled by Main Roads WA the application is to be referred to that authority for endorsement,
 - g) Installation on Shire controlled lands is to be by Shire staff and charged at private works rates, or by a contractor agreed by the Shire under such terms and conditions as considered appropriate,
2. Business or non-government services signage, excluding Emergency Service signs if supplied by the provider, is not permitted to be installed in the CBD and adjacent areas.
3. Signage on roads controlled by Main Roads WA is to be referred to Main Roads WA for consideration and approval.

– End of Policy

Notes

12.9 After Hours Use of Depot, Plant, Vehicles, Equipment and Tools

Statutory context	Local Government Act 1995
Corporate context	Delegations Register – - 3.11 – Donations – Financial and In Kind Works / Services Policy Manual – - 12.6 – Private Works Code of Conduct – Employees
History	Adopted 26 April 2017 Formerly Policy 14.1 Amended 24 July 2019 Last reviewed 7 June 2021

Policy Statement

1. Depot

Private use of the depot facilities is not permitted.

Use of plant, vehicles etc

2. Private use of plant, equipment etc is not permitted, except in accordance with Policy 12.6 Private Works.

3. The Shire's plant or vehicles are not to be used for commercial use, or for personal profit or reward.

4. Where use has caused damage, the CEO or EMTRS, may charge the costs incurred to the employee.

5. All items must be returned in a clean, refuelled and fully operational condition in a ready to use state prior to the commencement of work.

6. Use of equipment and tools

Private use of equipment and tools is not permitted.

Eg: chainsaws, lawn mowers, brush cutters, generators, cement mixers, ladders etc

7. Assistance for Sporting or Community Groups

a) The use of Shire plant by staff outside of normal hours may be permitted to assist sporting or community groups serving the residents of Narrogin providing the normal plant / equipment hire rate is paid by that body, unless otherwise allowed by the CEO.

b) Delegation 3.11 Donations – Financial and In-Kind Works/Services may be applied at the discretion of the CEO.

c) If approved by the CEO or EMTRS, the plant is to be operated only by a competent employee – non-employees or a non-qualified employee are not permitted.

– End of Policy

Notes

12.10 Plant, Equipment and Vehicle Replacement

Statutory context	Local Government Act 1995	
Corporate context	None	
History	Adopted	26 April 2017
	Amended	27 September 2017
	Formerly	Policy 14.2
	Last reviewed	24 July 2019
	Last reviewed	7 June 2021

Policy Statement

The purpose of the replacement policy is to ensure that the plant and vehicles –

- meet safe operational needs;
- minimise the cost of maintenance and repairs and
- are replaced at appropriate intervals so as to minimise cost to the Shire.

Category	Description	Preferred replacement period
Light Vehicles – Admin	Utilities, cars and 4x4	60,000-80,000 or 2 years (unless more cost-effective arrangements for more regular changeovers being at a minimum of every 15,000 kms can be obtained)
Light vehicles – Depot	Utilities, cars and 4x4	120,000 km or 3 years (unless more cost-effective arrangements for more regular changeovers being at a minimum of every 15,000 kms can be obtained)
Buses	Buses	200,000 km or 7 years (subject to any grant conditions or usage)
Trucks – light	2.5 up to 8 tonnes	150,000 km 7 years
Trucks – medium, heavy	Over 8 tonnes	300,000 or 7 years
Road sweepers	Self propelled	As required
Ride on mowers	All sizes	4 years
Light plant	Tractors up to 60 kW, skid steer loaders and similar	5 years
Medium plant	Backhoes	7 years
Heavy plant	Graders, bulldozers, excavators and similar Front end loaders, tractors (over 60 kW) and similar Forklifts	10 years
Trailers	Less than 6 tonne capacity More than 6 tonne capacity	As required
Miscellaneous equipment A	Chain saws & whipper snippers Walk behind mowers Cement mixers Plate compactors & tampers Portable fire pumps and similar	As required
Miscellaneous equipment B	Welders, air compressors	As required

Category	Description	Preferred replacement period
Trailer mounted generators		5 years
Tractor and skid steer loader attachments	Slashers, turf mower and similar	As required

– End of Policy

12.11 Asset Management

Statutory context Local Government Act 1995
Local Government (Financial Management) Regulations 1996
Australian Accounting Standard 27

Corporate context Asset Management Plans and Strategies
Long Term Financial Plan
Corporate Business Plan

[Policy Manual –
- 3.10 – Portable and Attractive Assets](#)

Annual Budgets

History Adopted 22 August 2018
Formerly Policy 14.3
Last reviewed 24 July 2019
[Amended 23 June 2021](#)

Policy Statement

Objective

Sustainable service delivery through optimised lifecycle management of assets –

- demonstrate the local government's commitment to strategic asset management as described in framework guidelines provided to local government as part of Integrated Planning and Reporting requirements of the Local Government Act;
- provide guidance for elected members during annual budget process;
- provide guidance for staff responsible for development of asset plans and programs; and
- provide the community with a statement of intent regarding asset management.

This policy applies to –

- all who are involved in the operations, maintenance, refurbishment, renewal, upgrading and development of local government's existing and new infrastructure and other assets;
- all of the local government's assets which include physical features such as roads, drainage, buildings, parks, pathways, play grounds, plant and other assets that are not fixed in place.

Principles

The local government will procure, maintain and dispose of its assets in line with this policy and regulatory requirements.

The local government aims are to develop and implement cost-effective management strategies for the long term and strive for continuous improvement in asset management practices.

There are five core principles that this policy has regard for –

Principle 1: Understand the Community's Needs

Levels of service for each asset class will be detailed in line with community expectations and regulatory requirements. These levels of service will be determined-

- in words that are readily understood by the community,
- with regard to the cost of provision of these services to the desired level of service, and

- with an understanding of longer term changes necessary as a result of changing demographics within our community.

Principle 2: Be Financially Sustainable

The local government will develop annual asset plans and programs generated from rolling 10/20 year plans aligned to Corporate Plans, Asset Management Strategies, Long Term Financial Plan and Workforce Plan, updating each plan as necessary based on relevant decisions made.

Where relevant, consideration will be given to life cycle costs regarding decisions to renew, upgrade or procure significant assets before any decision is made.

The local government maintenance of assets shall be funded primarily from rates revenue and this shall be taken into regard when decisions are made to procure new assets. Where limits on rates funding exist, precedence shall be given to necessary maintenance activities for existing assets over proposals to procure new assets from this funding source.

The local government will continually review its stock of assets and undertake consolidation of assets where it is in the best interests of the community.

Principle 3: Recognise Environmental Impact

The local government will consider and amend asset programs as necessary, where practical and financially acceptable options exist for reducing energy or water consumption, reducing carbon impact, reducing consumption of non-renewable resources and preserve or enhance the environment in which we live.

Improvements in our asset management systems will be undertaken to ensure measuring and monitoring of consumption of resources are in place to better understand the implications for long term asset management.

Principle 4: Continuous Improvement

Asset management processes will be developed that include a systematic approach to planning, implementing, reviewing and modifying asset management activities to improve the efficiency and efficacy of the overall system.

Processes will be developed to ensure that the local government is aware of contemporary asset management practices and that staff and service providers undertake continuous improvement

Principle 5: Public and Staff Safety

All facets of the asset management process will have a risk based approach to designing and undertaking each stage of the process to ensure public and staff safety is not compromised.

Application

As there is a substantial investment in assets, the local government will endeavour to meet the service needs of the community, in a manner that does not place undue economic, social or environmental burden on future generations. Decisions relating to the provision and management of public infrastructure shall reflect the local government's core values, statutory responsibilities and accountability to the community.

To achieve this, the local government will –

1. Ensure that appropriate infrastructure and other assets are acquired, maintained and renewed to meet the needs of current and future stakeholders, at equitable intergenerational cost.
2. Undertake a critical review of the need for that asset.

3. Take into account **whole of life** costs associated with asset ownership when considering proposed capital investment or other related expenditure, including upgrade and renewal works.
4. Quantify and communicate the true cost of operating and maintaining assets, as a basis for setting service level standards and making informed decisions on asset purchase, maintenance and renewal.
5. Consult with key stakeholders to establish agreed service standards that reflect community expectations and willingness / propensity to pay.
6. Implement appropriate business practices and procedures to ensure that infrastructure and other assets are operated, maintained and renewed in accordance with agreed standards, at lowest **whole of life** cost to the community.
7. Where appropriate, engage the private sector and Government agencies to explore opportunities for alternative "non-asset" service delivery solutions, including public private partnerships and integrated / shared servicing arrangements.
8. Ensure that statutory and legal obligations with respect to the operation and maintenance of public infrastructure and other assets are effectively met, particularly with regard to public safety and security.
9. Continually seek opportunities for multiple use of assets.
10. Provide appropriate asset data and reporting to meet the needs of the end users/key stakeholders.
11. Develop and implement long term Asset Management Plans as determined by the CEO, for the key asset classes –
 - a) Transport assets – roads, paths, bridges, culverts, drainage, airport, street furniture etc.;
 - b) Property assets – buildings, freehold land and associated ancillary infrastructure;
 - c) Recreation assets – parks, ovals, reserves, gardens, playgrounds etc.;
 - d) Plant and equipment – vehicles, tools, plant and machinery, information technology and communications equipment etc.
 - e) Portable and attractive assets – in accordance with the *Local Government (Financial Management) Regulations 1996* r.17B; and
 - f) Other classes as deemed appropriate or necessary
12. Develop and implement an Asset Management Improvement Strategy detailing proposed business improvement actions and projects aimed at enhancing organisational effectiveness with respect to the management of assets.

13. Valuation and stocktake of assets –

- (a) fair value assessment is to be undertaken on a rotational basis for the assets identified in the Financial Management Regulations r.17A(2) or directed by the CEO or Executive Manager Corporate & Community Services;
- (b) stocktake of moveable (non-portable and attractive) assets within a class is also to take place within 1 month when directed to be undertaken by –
 - (i) CEO;
 - (ii) Executive Manager Corporate and Community Services for any area of Shire operations; or
 - (iii) Executive Manager for the relevant Department.

– End of Policy

Notes

Asset, for the purposes of this policy, includes a physical component of a facility which has value that enables services to be provided and has an economic life greater than 12 months.

[Stocktake](#), for the purposes of this policy, requires that the asset/s be physically sighted and counted, and reconciled to the records held.

12.12 Restricted Access Vehicles on Shire Roads

Statutory context	Local Government Act 1995
	Road Traffic (Vehicle Standards) Regulations 2002
	Local Planning Scheme and relevant policies
	Public Places and Local Government Property Local Law 2016
Corporate context	Delegation 12.10 – Restricted Access Vehicles on Shire Roads
	Roads Asset Management Planning
History	Adopted 26 April 2017
	Formerly Policy 16.1
	Amended 24 July 2019
	Last reviewed 7 June 2021

Policy Statement

- The following Policy Schedules are adopted, and form part of this Statement –
 - 12.12(a) – Information for application to Use Shire Roads
 - 12.12(b) – CA07 Conditions that may be applied
 - 12.12(c) – Components for Agreements to Use Shire Roads
 - 12.12(d) – Calculation of User Contributions
- Vehicle combinations 2 (truck and trailer) over 19 metres, 3 (B-double) and 4 (pocket road train) but not exceeding 27.5 metres in length (Restricted Access Vehicles) may be permitted on local roads subject to approval by the CEO or EMTRS.
- CA07 conditions as per Policy Schedule 12.12(b) CA07 Conditions that may be applied will be applied where considered necessary or appropriate to manage RAV access in order to –
 - preserve the condition of the road infrastructure,
 - improve the road to a standard appropriate for the proposed vehicle movement,
 - reduce the economic cost to the community caused through heavy vehicle damage, and
 - mitigate impact on community amenity of noise, dust, hours of operation, public safety etc.
- Where a CA07 condition exists, RAV operators must –
 - complete and lodge a written application, providing all necessary information in accordance with Policy Schedule 12.12(a) Information for Application to Use Shire Roads,
 - details of proposed contributions, if any, towards road improvement / replacement / maintenance, community benefit etc, in accordance with Policy Schedule 12.12(d) – Calculation of Contributions,
 - provide any other relevant information requested,
 - pay the CA07 application/assessment fee as determined by the Annual Budget.
- Where road users apply for a CA07 authority to operate Restricted Access Vehicles on roads in the Shire that are classified under the Main Roads WA permit network, the user may be required to enter into a Road Use (Restricted Access Vehicle Haulage) Agreement with the Shire.
- Where a user requests sections of road to be upgraded to a standard higher than Council considers necessary for the surrounding or usual usage, Council will apply the principles of Policy Schedule 12.12(c) Components for Agreement to Use Shire Roads to the proposal.

7. The Agreement will be a legally binding contract addressing the matters in Policy Schedule 12.12(c) Components for Agreement to use Shire Roads in a standard format that will be developed and updated from time to time under professional advice from the Shire's engineers and lawyers.
8. Council will require the other party to the Agreement to bear all costs associated with the Agreement including but not limited to legal fees involved in entering into the agreement, and the cost of all professional and engineering advice.
9. The Agreement is to address matters in accordance with Policy Schedule 12.12(c) Components for Agreement to Use Shire Roads:
10. Where considered appropriate, the Shire may convene, or request the user to convene, user groups for the purpose of establishing forward works programs on the affected roads and to identify and address safety issues.
11. Prior to the approval being issued –
 - a) Agreement in writing by both the user and the Shire is required (formal contract/agreement or exchange of letters)
 - b) Agreed contributions for road use and community benefit to be paid
 - c) Main Roads WA advised
12. Approval to operate is subject to an annual licence expiring 30 September.
13. Non-compliance with Council requirements will result in withdrawal of approval for use of the road.

– End of Policy

Notes

Note – requirements are intended to be consistent with relevant provisions of the Shire of Narrogin Extractive Industry Local Law.

Main Roads WA issues road network use permits for RAV (restricted access vehicles). Where the road network includes Shire roads, a local government can impose a CA07 conditions for RAVs that requiring the operator to carry written approval from the Shire permitting use of the road.

RAV traffic (ie: multi-trailer heavy vehicles) results in significantly increased cost to maintain the road asset, particularly if the road construction is not designed or intended to sustain such traffic. Wear and tear increases proportionally with the vehicle length, number of trailers, axle combinations and weight of the load carried.

The Shire constructs, maintains and renews road assets generally in line with expectations or requirements of local users, with funding from rates, financial assistance grants, regional roads group funding and federal funding, and does not have funding to construct or maintain road assets for heavy haulage by Restricted Access Vehicles (RAV)..

It is important that the Shire receives adequate compensation from users to ensure the construction, maintenance and renewal of its affected road assets.

Council is committed to maintaining its road assets in accordance with the integrated long term financial and asset management plans.

Policy Schedule 12.12(a) – Information for Application to Use Shire Roads

The information is to cover the following minimum provisions where relevant to the application –

- a) Applicant details –
 - Applicant details – name, mail & street address, phone etc
 - Contact person – name, position, phone, email etc
- b) Haulage contractors (required for each contractor having a significant freight task) –
 - Contractor details – name, mail & street address, phone etc
 - Contact person – name, position, phone, email etc
- c) Term of application –
 - Commencing date
 - Termination date (estimated)
- d) Route (required for each different route) –
 - Origin and Terminus
 - Journey / route
 - Distances
- e) Vehicles and combinations (required for each route) –
 - class of vehicle and configurations,
 - number of vehicles,
 - frequency and hours of operation,
 - estimated tonnages and concessional loadings
- f) Dangerous goods (in order to advise local emergency services) –
 - Type
 - Frequency
 - Quantities
 - Emergency contact details
- g) Other relevant information, such as –
 - Maps
 - Engineering assessment if held
- h) Authorisation of application –
 - Name, signature of authorised person and date

Applicants to note –

- Approvals will be assessed in accordance with any Shire of Narrogin Planning Policy Developer Contributions – Local Roads, and may take up to 8 weeks to process depending on the timing of receipt.
- Operation of a Restricted Access Vehicle on any road in the Shire constitutes an offence under the Road Traffic (Vehicle Standards) Regulations 2002 unless the operator holds a valid permit issued by Main Roads WA **and** a valid letter of authority from the Shire to comply with a CA07 condition.
- The operator must adhere to all conditions imposed by Main Roads WA and additional conditions if imposed by the Shire:
- Approval of application constitutes a letter of authority in compliance with the CA07 requirement of a valid RAV permit.
- Letter of authority does **NOT** constitute a permit. The holder must only operate a restricted access vehicle on any road in accordance with a valid permit issued by Main Roads WA

Note – requirements are intended to be consistent with relevant provisions of the Shire of Narrogin Extractive Industry Local Law.

– End of Schedule –

Policy Schedule 12.12(b) – CA07 Conditions that may be applied

<https://www.mainroads.wa.gov.au/UsingRoads/HeavyVehicles/ravnetworkaccess/Pages/default.aspx> on 5 March 2017

Main Roads Heavy Vehicle Services (HVS) is responsible for administering road access for Restricted Access Vehicles (RAVs).

RAVs are vehicles that exceed any of the following –

- a width of 2.5 metres;
- a height of 4.3 metres;
- a length of 19 metres for a vehicle combination;
- a length of 12.5 metres for a rigid vehicle;
- a gross mass of 42.5 tonnes;
- any other mass or dimension limit prescribed in the Road Traffic (Vehicles) Regulations 2014.

RAVs must only operate on roads approved by Main Roads, under either an order (notice) or a permit.

There are many types of RAVs and each of them has different performance characteristics, require a different amount of road space when operating and have a different impact on the road infrastructure. For this reason, it is necessary to assess the roads these RAVs operate on to ensure the road is suitable for the particular type of vehicle and the safety of other road users is not compromised.

Main Roads Heavy Vehicle Services (HVS) works collaboratively with the relevant road asset owner to ensure roads are suitable for RAV access. RAV Networks are maintained for the various types of RAVs and are published in the form of Road Tables and a RAV Mapping Tool.

Extract from – Main Roads WA Heavy Vehicle Operations
Standard Restricted Access Vehicle (RAV) – Route Assessment Guidelines
Version 3 – October 2016

APPENDIX H – OPERATING CONDITIONS

Main Roads will apply the operating conditions below, as a condition of permit, to very low traffic volume roads when the road's width does not meet the minimum requirements in Appendix B.

These and other similar operating conditions may be applied to the assessment of other roads.

1. When travelling at night, the RAV must travel at a maximum speed of 40km/h and display an amber flashing warning light on the prime mover.
2. No operation on unsealed road segment when visibly wet, without Road Owners approval.
3. Headlights must be switched on at all times.
4. Speed restrictions. *
5. Direct radio contact must be maintained with other RAVs to establish their position on or near the road (suggested UHF Ch 40).
6. Road not to be entered until driver has established by radio communication that there is no other RAV on the road travelling in the opposing direction.
7. Operation is not permitted while the school bus is operating on the road. Operators must contact the relevant schools and obtain school bus timetables; or where direct contact can be made with the school bus driver, operation is permitted once the school bus driver confirms all school drop-offs/ pick-ups have been completed on the road.
8. Current written approval from the Road Owner, endorsing use of the road, must be obtain, carried in the vehicle and produced upon request.

These conditions are applied in the Prime Mover, Trailer Combinations and Truck, Trailer Combinations Operating Conditions. The applicable roads must be clearly identified as either a "Type A" Low Volume Road or a "Type B" Low Volume Road as a road condition.

*40 km/h or 60 km/h as determined from Appendix C.

– End of Schedule

Policy Schedule 12.12(c) – Components for Agreement to Use Shire Roads

The Agreement may include but is not limited to the following provisions, as appropriate and as determined by the Shire –

- a) Principles –
 - The safety of road users is paramount, and takes priority over developer activity
 - residents should appropriately contribute to assessed public maintenance of the road
 - residents should not fund construction or maintenance required for private benefit
- b) Safety Management –
 - The developer will be required to prepare and lodge a road safety risk assessment and management plan with the Shire for whole route that is in the Shire, including roads under control of MRWA.
 - Shire to action matters advised as a priority, subject to seriousness of issue
- c) Construction, or upgrade/renewal as required –
 - As per Policy Schedule 12.12(d) clause 1 Construction, upgrade and renewal.
- d) Road Design –
 - When giving consideration to the construction of a road, the Austroads standards should be applied
 - MRWA Heavy Vehicle Operations (HVO) requires inspection of a road to ascertain its ability to support RAV traffic.
 - Dependant on the category of vehicle (category 1 to 10, RAV class 2) will determine the depth of base, maximum allowable grades, width of seal, seal design and intersection treatments.
 - Vehicles should not be on a road unless it is constructed appropriately or agreement reached on upgrade over time.
- e) Guidelines –

Reference should be made to appropriate guidelines for the design of the works required, such as –

 - Roads –
 - o Australian Standards as are applicable,
 - o Relevant documentation supported by applicable professional associations
 - o Austroads – Vehicle Classification System, Designs and Guides
 - o MRWA – Specifications for Pavements
 - o MRWA – Restricted Access Vehicles, Permit Networks, Heavy Vehicle Access Road Maps
 - o MRWA, Heavy Vehicle Operations, Guidelines for Assessing the Suitability of Routes for RAV
 - Drainage catchment, and structural design –
 - o Australian Standards as are applicable – e.g. Loads on Buried Concrete Pipes, Precast Concrete Pipes
 - o Institute of Engineers – Australian Rainfall and Runoff – A quick guide to flood estimation Aug 1987
 - o Austroads – Design Codes and Guides for Bridges, Culverts and Floodways etc
 - o Concrete Pipe Association of Australia – guides and charts etc
 - o Australian Road Research Board – Guides for Stormwater drainage design in small urban catchments.
- f) Maintenance –
 - As per Policy Schedule 12.12(d) clause 2 Road Maintenance
- g) Adverse Conditions –
 - Developer to manage/restrict/cease operations voluntarily as appropriate
 - Adverse weather conditions, or other circumstances requiring temporary closure of the route
 - Claim to be made on MRWA by Shire for storm damage etc
 - Any gap not funded by MRWA remedial grants will be funded in equal shares by developer and Shire
- h) Security for road restoration and reinstatement –
 - i) For the purpose of ensuring that a road is maintained in an appropriate condition and standard, Council may require that a bond, bank guarantee or other security, in or for a sum determined by Council to be paid
 - ii) A bond required under subclause (1) is to be paid into a fund established by the Shire for the purposes of road maintenance.

- iii) If a bank guarantee or other security required ceases to be current, operations may be required to be cease until a further security has been provided.

- i) Payment –
 - The user will calculate and pay the amount to the Shire in advance at intervals of no less than quarterly.
 - The first payment will be non-refundable in its entirety.

- j) Community Amenity –
 - As per Policy Schedule 12.12(d) clause 3 Community Amenity

- k) Cessation of development / operations –
 - Any funds remaining to be directed to bringing the road up to a standard where renewal / upgrade for local use will not be required for at least 5 years
 - determination of standard required for 5 years by negotiation
 - assessment of required works to be certified by a mutually agreed qualified engineer as being adequate to the task
 - if after bringing up to the standard required for 5 years there is insufficient funds, invoice to be issued.

- l) Administration –
 - Engagement of external professional services to advise the Shire on matters relating to the agreement will be charged against the agreed developer maintenance contribution.
 - Engagement of external professional services is at the discretion of the Shire, and may include –
 - o Consulting engineer and other similar services directly related to the agreed route
 - o Legal advice deemed necessary for interpretation of the Agreement
 - o Other matters specifically relating to the Agreement or the agreed route

- m) Accountability –
 - Shire to provide annual report –
 - o funds received and expended
 - o Reserve Account activity
 - Developer to notify of –
 - o significant changes in traffic type or volume ,
 - o any safety issues on the road in a timely manner

- n) Dispute –
 - Priority is for resolution through direct negotiation
 - Should direct negotiation fail, a mutually agreed independent person to be appointed to make determination
 - Determination to be binding except in the case of manifest error

Note – requirements are intended to be consistent with relevant provisions of the Shire of Narrogin Extractive Industry Local Law.

– End of Schedule –

Policy Schedule 12.12(d) – Calculation of User Contributions

1. Road construction, upgrade, improvement –

To be addressed –

- a) Joint assessment and agreement in writing of the construction/renewal gap,
- b) Assessment of required works to be certified by a mutually agreed qualified engineer as being adequate to the task,
- c) Applicant/user/developer to fully fund the gap,
- d) Agreement as to who will carry out the construction works – Council responsibility or developer responsibility,
- e) On completion of works, prior to issue of approval, the works are to be –
 - i) inspected by an appropriate person appointed by the Shire,
 - ii) certified by mutually agreed qualified engineer, and
 - iii) formally resolved by Council,
- f) Should MRWA / RRG / RTR fund a portion, developer funds the reduced gap.

2. Road maintenance –

To be addressed –

- a) Maintenance requirements to be negotiated, and agreed in writing –
 - i) standards including frequency of completion of maintenance tasks,
 - ii) obligations to notify of change, matters for public safety etc.,
 - iii) regular inspection to ensure adequacy of conditions,
- b) Agreement as to who will carry out the maintenance works – Council responsibility or developer responsibility,
- c) Unspent developer maintenance contributions to be retained in a Reserve Account specifically for the road,
- d) If annual maintenance contribution is insufficient –
 - i) Shire to draw on Reserve, or
 - ii) issue an invoice.

Option 1 – Reference amount –

- Year 1 –
 - o Previous 5 years average maintenance for this or similar road (traffic, construction etc), each year CPI adjusted
 - o Add estimated increased annual maintenance cost
- Year 2 and following –
 - o Previous year's figure to increase annually by rural rate increase
 - o Maintenance in addition to annual reference amount resulting from road traffic damage (not wear & tear or storm damage etc) to be recovered from user.

Option 2 – Charge per tonne

- Year 1 –
 - o An agreed cents per tonne per kilometre
- Year 2 and following –
 - o Previous year's rate to increase annually by rural rate increase
 - o Maintenance in excess of the calculated figure for the year figure resulting from road traffic damage (not wear & tear or storm damage etc) to be recovered

3. Community amenity

An agreed contribution to mitigate impacts on community amenity as a contribution to the Shire's community programs and/or community infrastructure for the long term benefit of residents of the Shire –

- community safety – such as crosswalk / lights, advisory / warning signage, fencing of public areas
- noise, particularly at night – such as noise barriers, vegetation buffers
- dust or windblown materials in town sites – such as road sweeping or watering down, wash down bays
- inconvenience or congestion to other road users.

Note – requirements are intended to be consistent with relevant provisions of the Shire of Narrogin Extractive Industry Local Law.

– End of Schedule

12.13 Number Plates – Local Authority Fundraiser Series

Statutory context Department of Transport licensing requirements

Corporate context None

History

Adopted	26 April 2017
Formerly	Policy 16.2
Last reviewed	24 July 2019
<u>Amended</u>	<u>23 June 2021</u>

Policy Statement

1. This Policy applies to both the NO series and NGN series local authority number plates –
 - numbers followed by NO, and
 - numbers followed by NGN.
2. The charge for each set of plates will be set by Council at the annual Budget meeting.
3. The person applying for the number plates is to nominate a local non-profit group (sporting, charitable etc) on the application form.
4. The application form including approval of the non-profit group, is to be signed by CEO, Executive Manager Corporate and Community Services or [Manager Corporate Services](#) prior to sending to Department of Transport for manufacture of the plates.
5. Unless replacing previously issued plates, leading zeros will not be accepted, e.g. 019 NO or 008 NGN, etc.

– End of Policy

Notes

Deleted: Manager Finance

Section 13 - NATURAL RESOURCE MANAGEMENT

13.1 Road Reserves – Clearing

Statutory context	Local Government Act 1995
	Environmental Protection Act 1986
	<ul style="list-style-type: none">- s.3(1) – definition of “native vegetation” includes dead vegetation- s.51A – definitions of “clearing” and “clearing principles”- Sch.5 – Principles for clearing native vegetation – Native vegetation not to be cleared if –<ul style="list-style-type: none">o cl.1(b) – whole or part of a significant habitato cl.1(e) – a significant remnant in an extensively cleared areao cl.1(f) – associated with a watercourse
	Environmental Protection (Clearing of Native Vegetation) Regulations 2004
	<ul style="list-style-type: none">- r.5 – Prescribed clearing s.51C –<ul style="list-style-type: none">o item 3 – clearing (by burning) for fire hazard reductiono item 11 – clearing along a fence line – Crown land (1.5m)o item 15 – clearing to maintain cleared areas around infrastructure etco item 21 – clearing for temporary bypass roado item 21A – clearing for crossovero item 22 – clearing for maintenance in existing transport corridorso item 23 – clearing resulting from infrastructure maintenance activities- Sch2 – Clearing for maintenance in existing transport corridors<ul style="list-style-type: none">o cl.2 – extent of clearing for an area or purpose in relation to a roado cl.3 – how the clearing is to be carried out
	Public Places & Local Government Property Local Law 2016

Corporate context

[Delegations Register](#)

[12.11 – Gates across roads / thoroughfares](#)

Deleted: None

History	Adopted	26 April 2017
	Formerly	Policy 15.1
	Last reviewed	24 July 2019
	Last reviewed	7 June 2021

Policy Statement

1. Clearing of a road reserve by any means, including fence lines, for construction or maintenance purposes, must be carried out in accordance with the Environmental Protection Act 1986, and the Environmental Protection (Clearing of Native Vegetation) Regulations 2004.
2. It is the responsibility of the landowner to ascertain if a Department of Environmental Regulation permit is required for any work proposed on a road reserve; in particular, for protection of any identified rare or endangered species of flora or fauna.
3. Any debris or spoil created by clearing of a fence line or the erection of a fence is to be removed from the road reserve and disposed of by the landowner on their property within 90 days.
4. The landowner is not permitted to alter any existing infrastructure or drainage when undertaking the clearing.

5. If needing advice, landowners are encouraged to consult with the Shire prior to any clearing of a road reserve.

– End of Policy –

Notes

Environmental Protection Act –

- s.3 – definition – **native vegetation** includes dead vegetation unless ... excluded by regulation ...
- Sch.5 – Principles for clearing native vegetation –
Native vegetation not to be cleared if –
 - o cl.1(b) – whole or part of a significant habitat

Note – includes not just live standing vegetation but also dead vegetation and debris, as this is considered to be habitat and harbourage for ground dwelling fauna. So if pushed tress, cut branches etc are removed within 90 days, no problem, but if left there for a carefully unspecified time, would be considered to have become habitat for ground dwelling fauna

Refer –

- s.3A(2) –
environmental harm means direct or indirect –
 - (a) harm to the environment involving removal or destruction of, or damage to —
 - (i) native vegetation; or
 - (ii) the habitat of native vegetation or indigenous aquatic or terrestrial animals; or
 - (b) alteration of the environment to its detriment or degradation or potential detriment or degradation;
or
 - (c) alteration of the environment to the detriment or potential detriment of an environmental value; or
 - (d) alteration of the environment of a prescribed kind;

13.2 Road Reserves – Cutting Firewood

Statutory context	Local Government Act 1995	
	Public Places & Local Government Property Local Law 2016	
Corporate context	Delegation 11.3 – Public Places & Local Government Property Local Law 2016	
History	Adopted	26 April 2017
	Formerly	Policy 15.2
	Last reviewed	24 July 2019
	Last reviewed	7 June 2021

Policy Statement

1. Application to cut or collect firewood from a road reserve is to be made to the CEO.
2. Conditions applying to any approval granted –
 - a) At no stage is the activity to create a traffic hazard
 - b) Only dead timber is allowed to be cut
 - c) All residue to be stacked neatly so as not to cause a nuisance on road verge
 - d) Care to be taken to protect existing flora and fauna
 - e) Wood may be taken only in non-commercial quantities and for domestic use
3. It is the responsibility of the applicant to ascertain if a Department of Environmental Regulation permit is also required.
4. A collector not complying with this policy may be issued a notice to cease activity or to comply under relevant legislation or local law, up to and including cancellation of licence, issue of an infringement notice or prosecution for non-compliance of conditions of licence.

– End of Policy

Notes

Partially covered by Public Places & Local Government Property Local Law

13.3 Street Trees

Statutory context Shire of Narrogin Public Places and Local Government Property Local Law 2016

Corporate context Delegation 11.3 – Public Places and Local Government Property Local Law 2016
[Street Tree Planning: Selections and Recommendations Guide 2018.](#)

History

Adopted	24 October 2018
Formerly	Policy 15.3
Last reviewed	24 July 2019
Last reviewed	7 June 2021

Policy Statement

Purpose

1. To manage the planting, maintenance and care of street trees in public places and on local government property, in particular but not limited to road reserves, within the town sites of Narrogin and Highbury.
2. Trees are a valuable community asset, enhancing both the built and the natural environment of the Shire. They contribute to the well-being of the community and through their longevity serve as a cultural link through generations.
3. The Shire of Narrogin recognises these values and is committed to the protection and maintenance of trees whilst maintaining its obligations to provide a safe environment.

Application

1. Area of Application

This policy applies to –

- a) Narrogin townsite, and
- b) Highbury townsite

2. Tree Protection

- a) All trees on land under the care and control of the Shire of Narrogin will be protected in accordance with relevant local laws, regulations and acts and these guidelines.
- b) Significant trees on Shire and public property will be recorded in the *Street Tree Planning: Selections and Recommendations Guide 2018*.
- c) For development applications, retention of mature trees or trees of significance on public property may be included as a condition of approval.
- d) Trees on private property are the responsibility of the land owner.

3. Tree Removal

- a) Authorisation:
Removal of any tree on Shire of Narrogin controlled property can only be given by the Executive Manager, Technical and Rural Services (EMTRS), or the Chief Executive Officer (CEO). Disputes may be subject to formal referral to Council. Applications for tree removal must be in writing stating the reason why the tree should be removed.
- b) Replacement:
In most instances of tree removal and where practicable, a replacement tree will be planted in a suitable location at the discretion of the EMTRS with reference to the *Street Tree Planning: Selections and Recommendations Guide 2018*.
- c) Removal not justified:
Tree removal will not be justified by any of the following reasons:
 - i) Tree obscuring commercial advertising signs

- ii) The growth of the tree is obstructing views
- iii) Tree litter/leaf fall/debris
- iv) Tree casting unwanted shade
- v) Resident requests an alternate species
- vi) A perceived danger a tree might fall in a storm

d) Removal justified:

Tree removal may be justified by any of the following reasons:

- i) The tree is dead or dying and remedial techniques are not possible
- ii) The tree is causing damage to property, infrastructure or public utilities and the cost of remedial works outweighs the value of the tree
- iii) Where, subsequent to a risk assessment undertaken by the Shire of Narrogin, the tree presents an immediate danger to the public

4. Tree Planting and Replacement

- a) The Shire shall be responsible for the planting and replacement of all street trees, trees in parks and trees on land under the care and control of the Shire of Narrogin.
- b) Trees will be chosen from the approved species list in the *Street Tree Planning: Selections and Recommendations Guide 2018*, by the EMTRS.
- c) Trees under power lines whether new or replacement planting, will only be low growth species as listed in the *Street Tree Planning: Selections and Recommendations Guide 2018*, with the aim of reducing pruning costs and making better use of the Shire's resources.
- d) Well established trees will continue to be pruned as required, unless they are deemed as an unsuitable species by EMTRS whereby they may be removed.
- e) All tree planting near assets such as footpaths, roads, fences, installations such as electricity, water and other utilities where root invasion may cause damage to such asset will include the installation of root guards, to reduce or eliminate damage to other assets and property
- f) Trees should be planted in winter, preferably June and July
- g) Local native species will be used when planting in rural or bushland areas.

5. Street Tree Pruning and Maintenance

- a) Pruning and maintenance of trees will be undertaken by the Shire of Narrogin in an annual program which gives priority to under powerline pruning, the Central Business District (CBD), parks and other significant public spaces, and attends to other trees on an as needs basis.
- b) Tree pruning will only be authorised to be undertaken by personnel approved by the Shire of Narrogin who have suitable training and practical experience in arboricultural techniques. Trees under powerlines will be pruned to meet clearance requirements as directed by Western Power or other electrical utilities of the day.
- c) Pruning will not be carried out for purposes such as to improve views, reduction of leaf fall debris, to provide visual access to commercial signs reduction of shade or other reasons that may detract from the natural amenity and purpose of the tree or where pruning will affect the health and structural integrity of the tree.
- d) The Shire of Narrogin may water new tree planting through the first two years on an as needs basis. Should a resident wish to water and care for a new street tree that is directly in front of or adjoining their property then the EMTRS may approve this.

6. Development Requests

- a) Where tree removal is approved in a development plan at the request of private land owners or commercial developers, the full cost of the tree removal including stump grinding and site remediation will be met by the applicant. All attempts must be made to retain healthy suitable trees in the first instance.
- b) Where the relocation of a crossover or a request for vehicular access requires tree removal the applicant must meet the cost of the tree removal as in 6(a). All attempts must be made to retain healthy suitable trees including finding an alternative location for a crossover so as to retain a tree.

- c) Where trees are indicated for removal on a streetscape plan, landscape plan or works program approved by the Shire, an equal number of trees may be planted in other suitable sites at the discretion of the EMTRS.
- d) All trees to be provided as a result of development requests will be chosen with reference to the *Street Tree Planning: Selections and Recommendations Guide 2018* and authorised by the EMTRS.

7. Public Awareness & Community Responsibility

- a) The Shire of Narrogin will encourage property owners to retain trees on private property, particularly where they contribute to the skyline or streetscape.
Residents wishing to extend garden planting onto their verge must seek permission from the Shire, ensuring thoroughfare is retained, and site lines are not hindered. The applicant will supply plan/design to the EMTRS for approval. The maintenance of verge plantings will be by the private land owner. The Shire reserves the right to remove the verge planting at any time due to disputes, the planting representing a hazard or at the discretion of the EMTRS.
- b) Businesses, schools and government organisations will be encouraged to develop and maintain appropriate plantings particularly on the street front verge. The maintenance of verge plantings will be by the private land owner. The Shire reserves the right to remove the verge planting at any time due to disputes, the planting representing a hazard or at the discretion of the EMTRS.
- c) Residents will be encouraged to monitor the needs of newly planted trees adjacent to their property and provide additional watering when required.
- d) Disputes between neighbours over trees that are not under the jurisdiction of the Shire will not be entered into, unless the tree presents a hazard, whereby the Local Government Act 1995 will be referred to.
- e) Annual street tree planting will be undertaken by the Shire. Residents will be able to request street trees to be planted on their verge by contacting the Shire. The tree species will be determined by the Shire of Narrogin with reference to the *Street Tree Planning: Selections and Recommendations Guide 2018*.

– End of Policy

Notes

Abbreviations

EMTRS – Executive Manager, Technical and Rural Services
CEO – Chief Executive Officer
CBD – Central Business District

Former Section 14 – Plant / Equipment transferred to Section 12

Former Section 15 – Natural Resources renumbered as Section 13

Former Section 16 – Unclassified transferred to Section 12

11. ELECTED MEMBERS' MOTIONS OF WHICH PREVIOUS NOTICE HAS BEEN GIVEN

Nil

12. NEW BUSINESS OF AN URGENT NATURE APPROVED BY THE PERSON PRESIDING OR BY DECISION OF THE MEETING

13. CLOSURE OF MEETING

There being no further business to discuss, the Presiding Member declared the meeting closed at ___ pm and, pursuant to resolution 1020.012 of 27 October 2020, reminded Councillors of the next Ordinary Meeting of the Council, scheduled for 7.00 pm on Tuesday 28 July 2021, at this same venue.



89 Earl Street, Narrogin
Correspondence to:
PO Box 1145, Narrogin WA 6312
T (08) 9890 0900
E enquiries@narrogin.wa.gov.au
W www.narrogin.wa.gov.au